

Indicators / Accessories Hardware



Section I

Q	<i>New!</i>	Panel mount LED indicators, up to 220VAC	12
VL		Panel mount LED indicators	13
B		15A and 25A terminal posts	15
20 to 500		Security caps <i>New models!</i>	16
		Hardware	112

With the recent introduction of new versions, APEM now offers the broadest range of LED indicators in the market:

- 7 diameters: 6, 8, 12, 14, 16, 19 and 22 mm,
- 3 bezel styles: prominent, recessed and flush
- 3 bezel finishes: bright chrome, black chrome and satin grey
- 6 standard power supply voltages: 6VDC, 12VDC, 24VDC, 28VDC, 110VAC and 230VAC
- 5 LED colours: red, green, yellow, blue and white
- Optional bicolour or tricolour LED's
- 3 output styles: solder lug/faston terminals, pins or wires

Options

- High brightness LED's (sunlight readable)
- Panel sealing to IP67
- Custom engraving on flush bezel versions
- Plastic bezels on 16 and 22 mm

Main specifications

- Typical viewing angle: 70° to 100° depending on model
- Long life expectancy: 100.000 hours
- Operating temperature range: -40°C to + 85°C

To benefit by the numerous advantages of LED technology (long life, low electrical consumption, low thermal dissipation, good impact resistance), APEM also offers a range of based LED lamps intended for replacement of less efficient filament lamps.

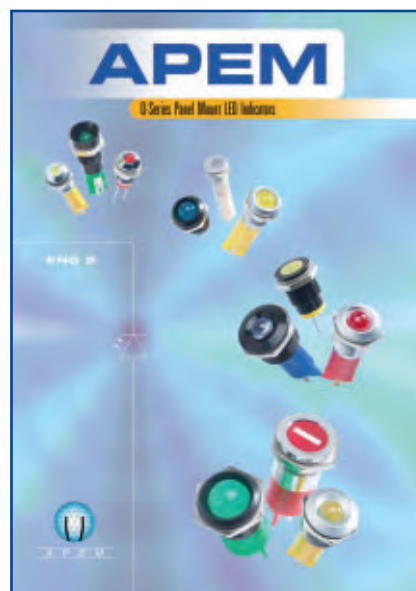

36-page catalogue on line and on request - www.apem.com

New!

- Indicators with built-in LED
New colours : blue and white
- Antirotation flatted bushing
- 2 bushing diameters : 6 mm (.236) and 8 mm (.314)
- Sealed or unsealed
- Bright or matt black chrome finish

ELECTRICAL SPECIFICATIONS

- Insulation resistance : 1.000 MΩ min.
- Dielectric strength : 250 Vrms 50 Hz min.
- Electrical life at high temperature : 72 H at 85°C

LED specifications (TA 25°C)

- Forward voltage : 2VDC ($\leq 2,6V$)
- Nominal current : 10mA
- Max. surge current ($t_p < 10\mu s$) : 0,5A
- Max. reversed voltage : 25V
- Max. forward current : 40mA
- Max. power dissipation : 100mW
- Correct polarity of D.C supply to diode electrodes must be observed :
 - longer lead : anode (+)
 - shorter lead : cathode (-) on flat side of bushing (see drawings).
- The LED is not removable.

MATERIALS

- Bushing and collar : brass, bright or matt black chrome plated
- Lens : polycarbonate
- LED

GENERAL SPECIFICATIONS

- Torque : 1,25 Nm (.922 Ft.lb) max. applied to nut
- Climatic category : 40/085/21
- Protection level for sealed models: IP 67 according to IEC 529
- In accordance with NFC 93680 standard

PANEL CUT-OUT

For \varnothing 6 (.236)

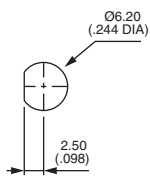

For \varnothing 8 (.314)

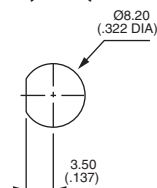

STANDARD HARDWARE

For \varnothing 6 (.236)

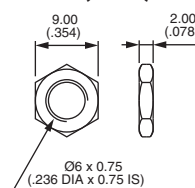

For \varnothing 8 (.314)

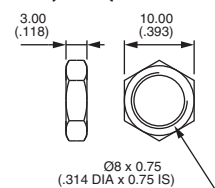

ABOUT THIS SERIES

Complete part numbers are shown on the following pages.

Dimensions : first dimensions are in mm while inches are shown as bracketted numbers.



Mounting accessories : standard hardware supplied with all models : nickel plated hex nut 9 mm (.354) across flats for indicators \varnothing 6 (.236) or 10 mm (.393) across flats for indicators \varnothing 8 (.314).



Packaging unit : 50 pieces.



VL series

Panel mount LED indicators

ermec@ermec.com

Diameter 6 (.236) - unsealed



LED colour	Bright finish (standard)	Matt black finish
Red	VL1000P600	VL100GP600
Yellow	VL1000P500	VL100GP500
Green	VL1000P300	VL100GP300
Blue	VL1000P100	VL100GP100
White	VL1000P700	VL100GP700

→ Flat

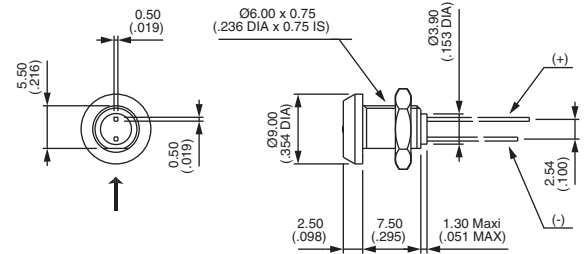

Max. panel thickness 5,50 (.216)

Diameter 8 (.314) - unsealed



LED colour	Bright finish (standard)	Matt black finish
Red	VL3000P600	VL300GP600
Yellow	VL3000P500	VL300GP500
Green	VL3000P300	VL300GP300
Blue	VL3000P100	VL300GP100
White	VL3000P700	VL300GP700

→ Flat

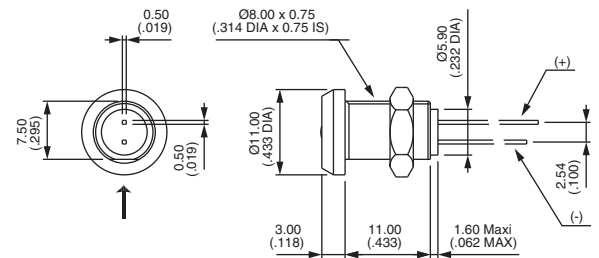

Max. panel thickness 8 (.314)

Diameter 6 (.236) - sealed



LED colour	Bright finish (standard)	Matt black finish
Red	VL1CK0P600	VL1CKGP600
Yellow	VL1CK0P500	VL1CKGP500
Green	VL1CK0P300	VL1CKGP300
Blue	VL1CK0P100	VL1CKGP100
White	VL1CK0P700	VL1CKGP700

→ Flat

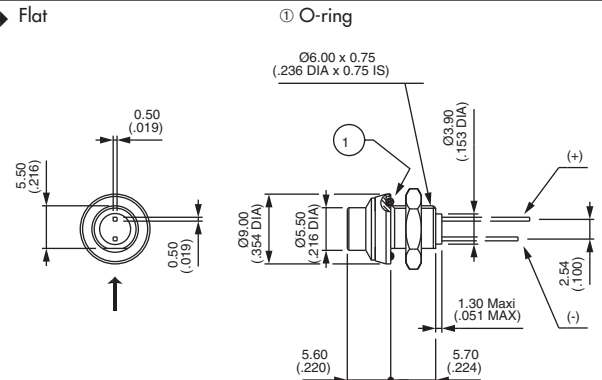

Lens cap in the same colour as the LED.

Max. panel thickness 3,70 (.145)

Diameter 8 (.314) - sealed



LED colour	Bright finish (standard)	Matt black finish
Red	VL3CK0P600	VL3CKGP600
Yellow	VL3CK0P500	VL3CKGP500
Green	VL3CK0P300	VL3CKGP300
Blue	VL3CK0P100	VL3CKGP100
White	VL3CK0P700	VL3CKGP700

→ Flat

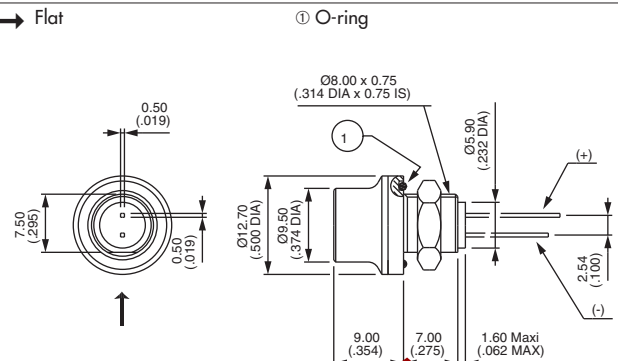

Lens cap in the same colour as the LED.

Max. panel thickness 4 (.157)



Option : Bushing without flat, lockwasher : on request.

www.ermec.com

B series

15A and 25A terminal posts

SPECIFICATIONS

- Dielectric strength : 15A type : 3.000 Vrms 50 Hz min. between shaft and panel
25A type : 4.000 Vrms 50 Hz min. between shaft and panel
- Short overload (< 2mn) : 50 % with cable lug
- Terminal connection by : - plug \varnothing 4 mm (.157), solder lugs, wire lead
- Operating temperature : -40°C to +70°C
- Packaging unit : 100 pieces or multiple per type and colour.

MATERIALS

- Shaft : brass, nickel plated
- Insulated nut : ABS molding over brass
- Other insulated parts : phenolic resin or melamine

Insulated terminal posts 15A



B1	Black
B11	Red
B12	Green
B13	Blue
B14	White
B15	Yellow
B16	Green / Yellow
B19	Orange

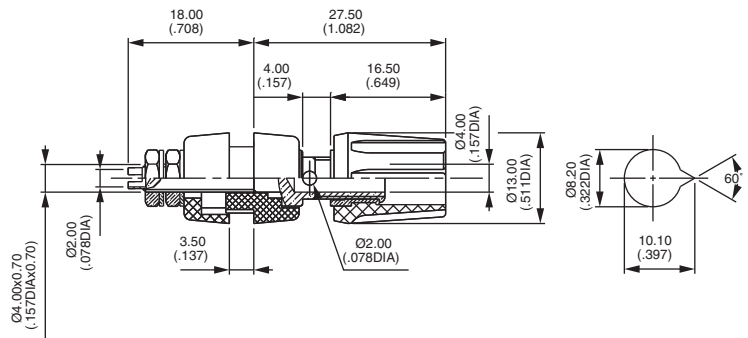

Non-insulated terminal posts 15A



B2	Black
B21	Red
B22	Green
B23	Blue
B24	White
B25	Yellow
B26	Green / Yellow
B29	Orange

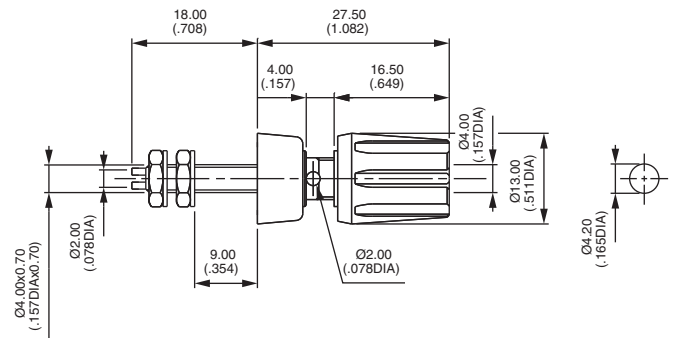

Insulated terminal posts 25A



B3	Black
B31	Red
B32	Green
B33	Blue
B34	White
B35	Yellow
B36	Green / Yellow
B39	Orange

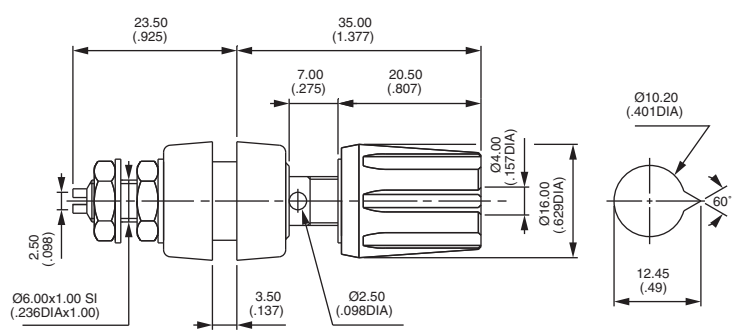

Non-insulated terminal posts 25A



B4	Black
B41	Red
B42	Green
B43	Blue
B44	White
B45	Yellow
B46	Green / Yellow
B49	Orange

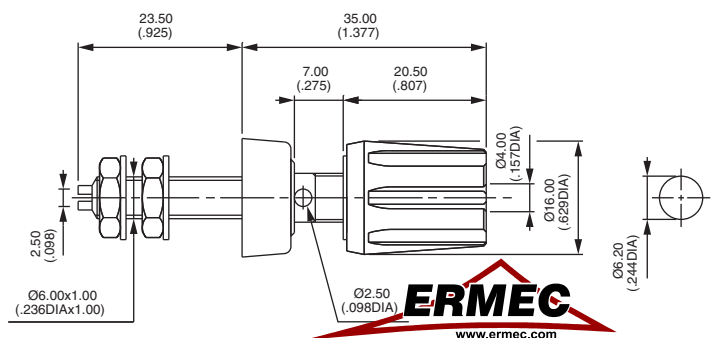

Dimensions : first dimensions are in mm while inches are shown as bracketted numbers.

www.ermec.com

Security caps

ermec@ermec.com

For switch series 12000 - 3500 - 600H - 6000

With standard bushing

Security caps prevent any inadvertent lever operation. When the cap is raised, the lever can be operated freely. When the cap is fully depressed, the lever is reset/locked in a stable position. They are designed for use on switches with $\varnothing 11,9 (.468)$ or $\varnothing 12 (.472)$ threaded bushing and lever length 17,5 (.688) outside bushing.

Note : For correct switch operation, the security cap should be adjusted properly by means of 2 nuts.

MATERIALS

- Support plate : matt black steel
- Cap : thermoset or thermoplastic (20PN, 200PN, 300PN)

MODEL STRUCTURE

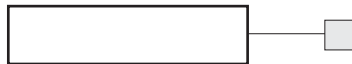

Series 20 - for 2-position switches

- Lever returned then locked in down position (OFF)



Model No	Colour
22	Grey
23	White
24	Orange
25	Black
26	Red
27	Green
28	Yellow
29	Blue
25/28	Black/yellow striped

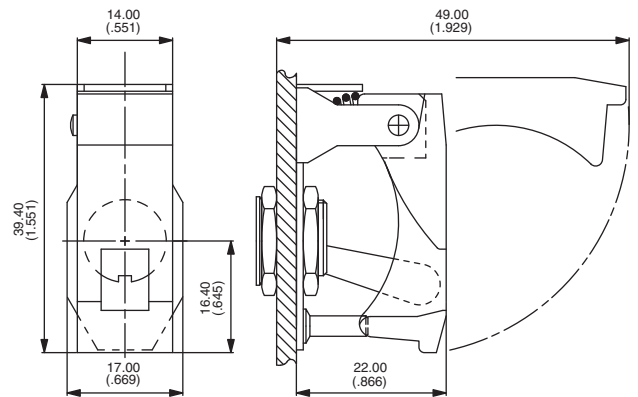

Series 20PN - for 2-position switches

- Lever returned then locked in down position (OFF)



Model No	Colour
22PN	Grey
23PN	White
24PN	Orange
25PN	Black
26PN	Red
27PN	Green
28PN	Yellow
29PN	Blue

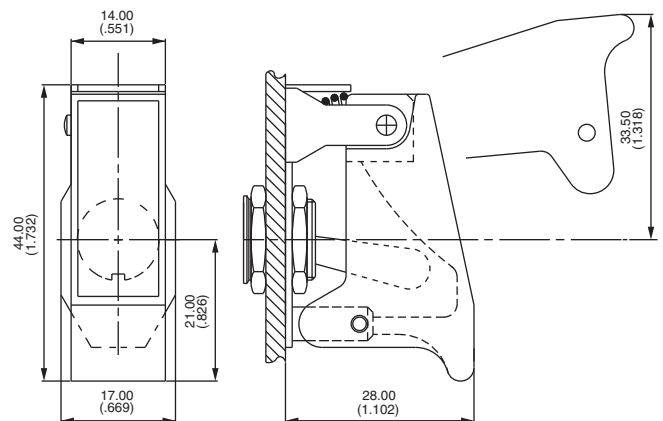

On this model, holes for wiring a seal are standard.

Series 30 - for 3-position switches

- Lever returned then locked in upper position



Model No	Colour
32	Grey
33	White
34	Orange
35	Black
36	Red
37	Green
38	Yellow
39	Blue
35/38	Black/yellow striped

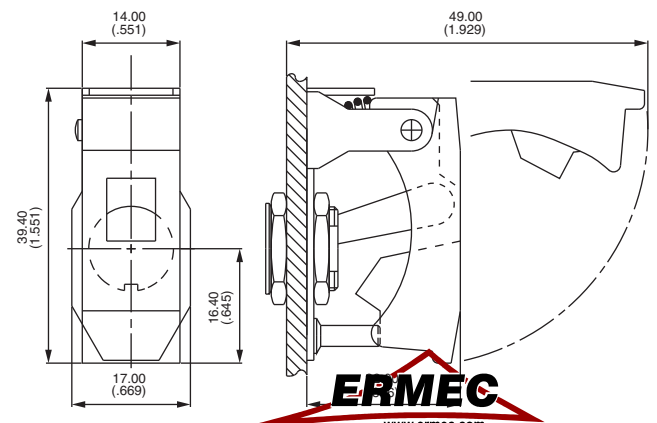

www.ermec.com

Security caps www.ermec.com

For switch series 12000 - 3500 - 600H - 6000

With standard bushing

Series 40 - for 2-position switches

- Lever returned then locked in upper position



Model No	Colour
42	Grey
43	White
44	Orange
45	Black
46	Red
47	Green
48	Yellow
49	Blue
45/48	Black/yellow striped

Model 140 (with smaller aperture) recommended for the 12000 series.

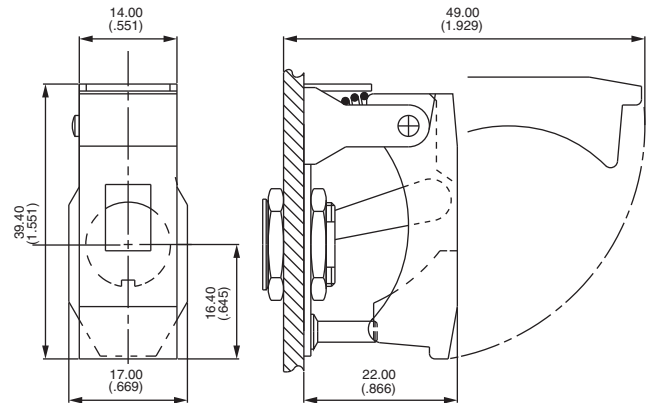

Series 80 - for 3-position switches

- Lever returned then locked in center position



Model No	Colour
82	Grey
83	White
84	Orange
85	Black
86	Red
87	Green
88	Yellow
89	Blue

New!

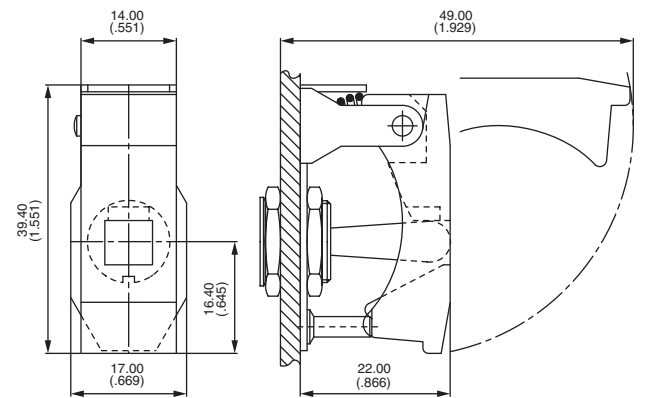

Series 200 - for 2-position switches

- Lever returned then locked either in lower or in upper position



Model No	Colour
202	Grey
203	White
204	Orange
205	Black
206	Red
207	Green
208	Yellow
209	Blue

New!

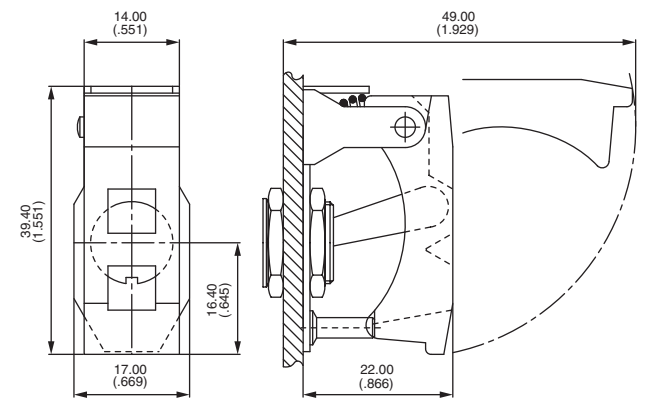

Series 200PN - for 2 or 3-position switches - action preventer

- Lever not locked, but protected in the position where left by the user



Model No	Colour
202PN	Grey
203PN	White
204PN	Orange
205PN	Black
206PN	Red
207PN	Green
208PN	Yellow
209PN	Blue

New!

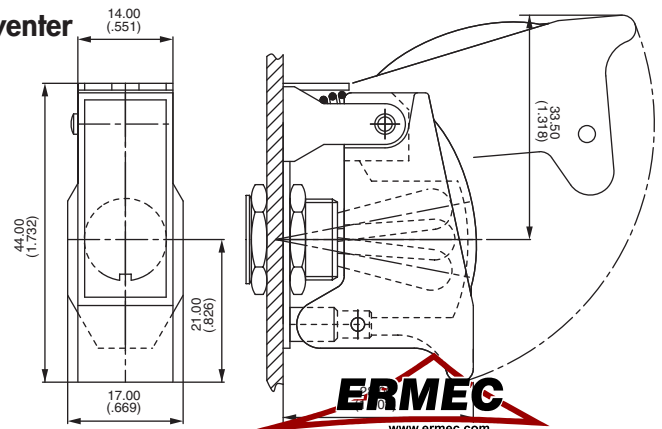

www.ermec.com

Security caps

ermec@ermec.com

For switch series 12000 - 3500 - 600H - 6000

With flatted bushing

Series 50 - for 2-position switches

- Lever returned then locked in down position (OFF)



Model No	Colour
52	Grey
53	White
54	Orange
55	Black
56	Red
57	Green
58	Yellow
59	Blue
55/58	Black/yellow striped

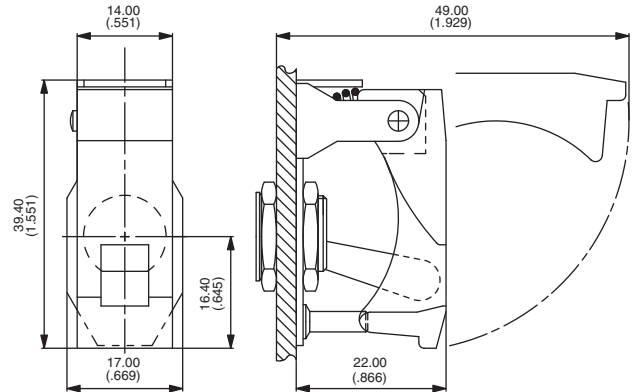

Series 60 - for 3-position switches

- Lever returned then locked in upper position



Model No	Colour
62	Grey
63	White
64	Orange
65	Black
66	Red
67	Green
68	Yellow
69	Blue
65/68	Black/yellow striped

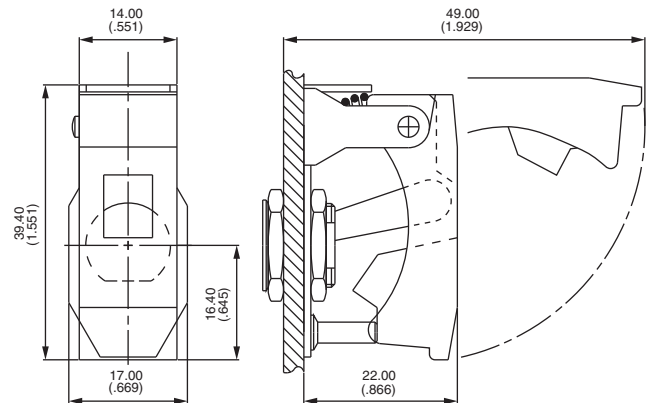

Series 70 - for 2-position switches

- Lever returned then locked in upper position



Model No	Colour
72	Grey
73	White
74	Orange
75	Black
76	Red
77	Green
78	Yellow
79	Blue
75/78	Black/yellow striped

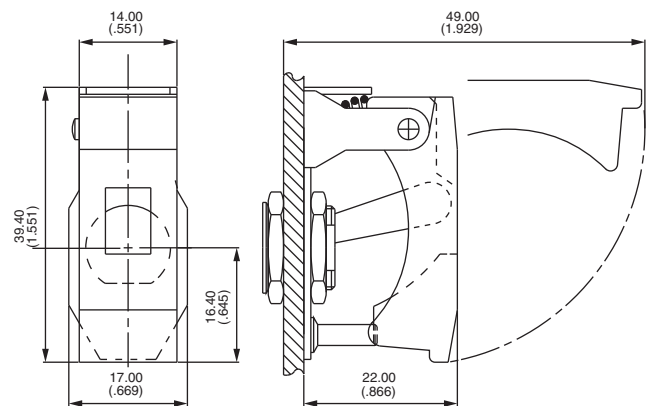

Model 170 (with smaller aperture) recommended for the 12000 series.

Series 100 - for 3-position switches

- Lever returned then locked in center position



Model No	Colour
102	Grey
103	White
104	Orange
105	Black
106	Red
107	Green
108	Yellow
109	Blue

New!

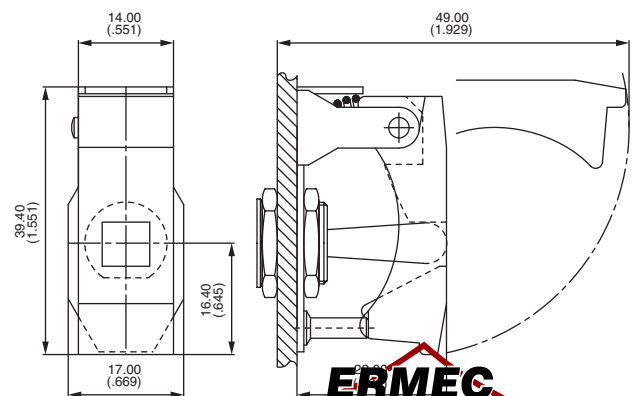

www.ermec.com

Security caps www.ermec.com

For switch series 12000 - 3500 - 600H - 6000

With flatted bushing

Series 300PN - for 2 or 3-position switches

- Lever not locked, but protected in the position where left by the user.



Model No	Colour
302PN	Grey
303PN	White
304PN	Orange
305PN	Black
306PN	Red
307PN	Green
308PN	Yellow
309PN	Blue

New!

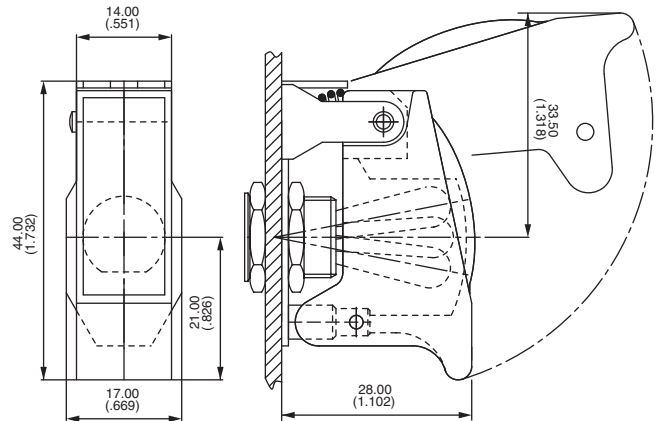

Series 500 - for 2-position switches

- Lever returned then locked either in lower or in upper position



Model No	Colour
502	Grey
503	White
504	Orange
505	Black
506	Red
507	Green
508	Yellow
509	Blue

New!

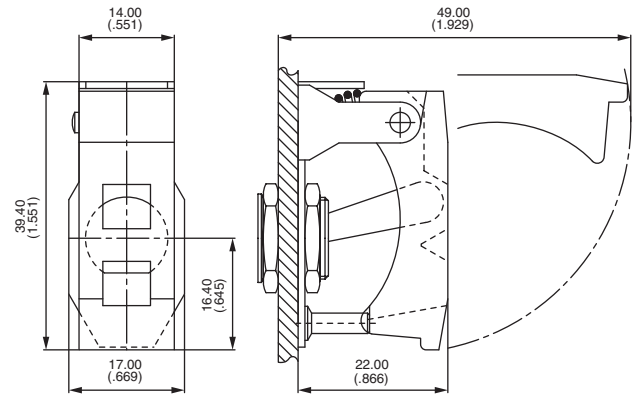

OPTIONS

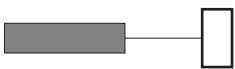

P Holes for wiring a seal

Cap engraving available : consult factory.

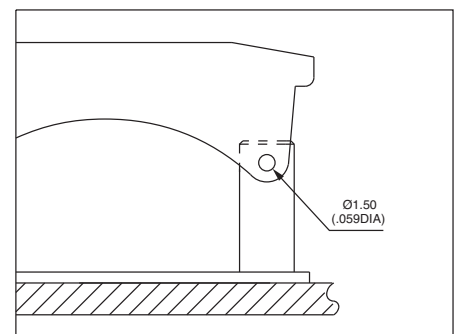

Security caps

ermec@ermec.com

For switch series 3500 - 600H - 6000

With standard or flatted bushing

Series 90

- Lever locked in center position

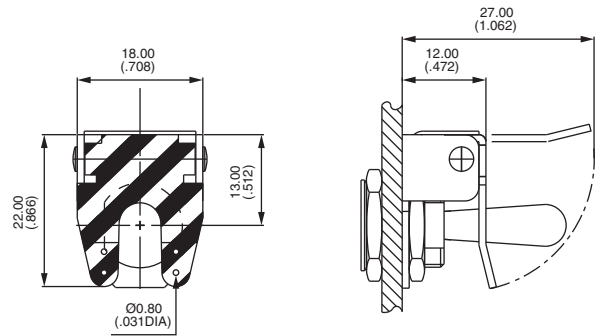

Plate features holes for wiring a seal.

To build a part number, select desired option from each category here below.

BUSHING SHAPES



For standard products

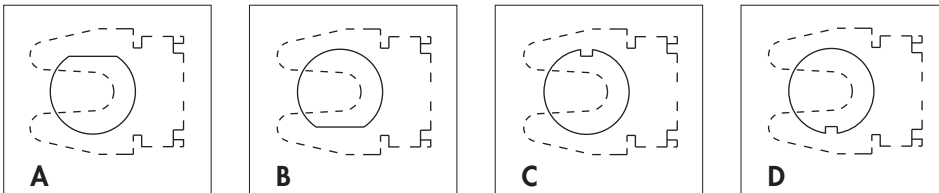

For other products

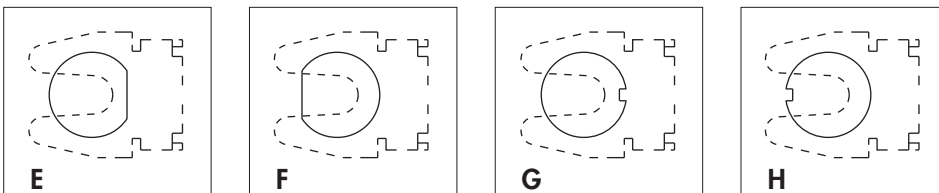

SECURITY CAP SHAPE

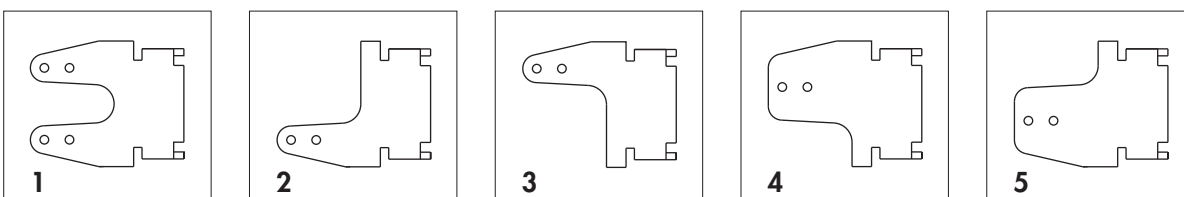

1
Locks in center position

2
Prevents down position

3
Prevents up position

4
Locks in down position

5
Locks in up position



www.ermec.com

Security caps www.ermec.com

For switch series 3500 - 600H - 6000 (continued) - For pushbutton series 13000

SECURITY CAP COLOURS



- | | |
|-----|---------------------|
| 1 | Blue |
| 2 | Black |
| 3 | Green |
| 4 | Grey |
| 5 | Yellow |
| 6 | Red |
| 7/1 | White |
| 9 | Orange |
| 0 | Striped (see below) |

COLOUR OF STRIPES

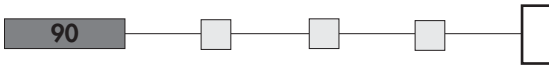

- | | Stripe ① | Stripe ② |
|---|----------|----------|
| A | Red | Black |
| B | Yellow | Black |
| C | Red | White |
| D | White | Black |

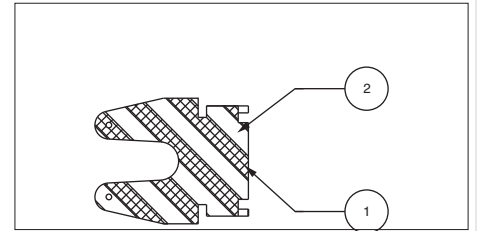

Series 90AX2328 for pushbutton series 13000

- Spring-loaded cover returning automatically in lower position. The user has to keep the cover raised while actuating the switch.

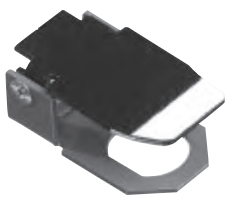

Model No	Colour
90AX2328-27	Black with white stripe
90AX2328-67	Red with white stripe

New!

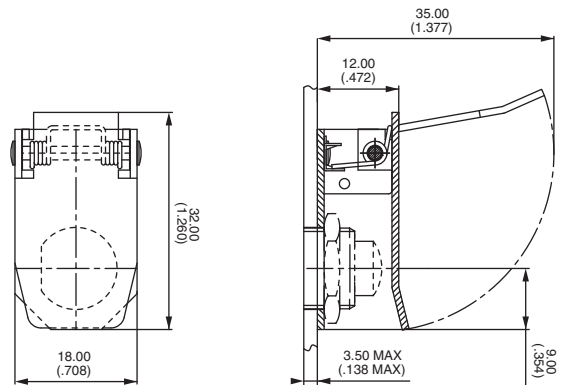

www.ermec.com

For miniature switches

- Standard hardware is automatically supplied with the switches
- Non standard hardware is to be ordered separately



Hardware supplied with sealing options :

- K version : 2 hex nuts + sealing washer
- X408 option : 1 hex nut + 1 O-ring

STANDARD HARDWARE FOR SWITCHES Ø 6 (.236) - 5000 SERIES

HEX NUT	LOCKING RING	LOCKWASHER
<p>9.00 (.354) 2.00 (.078) Ø6.00 x 0.75 SI (.236 DIA x 0.75SI)</p>	<p>Ø11.80 (.464 DIA) 6.20 (.244) 5.50 (.216) Ø6.10 (.240 DIA) 2.00 (.078) 0.80 (.031)</p>	<p>Ø9.50 (.374 DIA) 0.80 (.031) Ø6.50 (.255 DIA) 0.40 (.015)</p>
Nickel plated Matt black	Nickel plated Matt black	Stainless steel
U208 U726	U198 U728	U215

NON STANDARD HARDWARE FOR SWITCHES Ø 6 (.236) - 5000 SERIES

KNURLED NUT	SPECIAL NUT 12 (.472) ACROSS FLATS	KNURLED CAP NUTS
<p>Ø9.00 (.354 DIA) 2.20 (.086) Ø6.00 x 0.75 SI (.236 DIA x 0.75SI)</p>	<p>12.00 (.472) 2.00 (.086) Ø6.00 x 0.75 SI (.236 DIA x 0.75SI)</p>	<p>Ø9.00 (.354 DIA) 2.70 (.106) Ø5.20 (.204 DIA) Ø6.00 x 0.75 SI (.236 DIA x 0.75SI)</p> <p>Ø12.00 (.472 DIA) 2.60 (.102) Ø4.80 (.188 DIA) Ø6.00 x 0.75 SI (.236 DIA x 0.75SI)</p>
Chrome plated	Chrome plated	Chrome plated Matt black
U826	U1916	U461 U502
		Chrome plated U232

STANDARD HARDWARE FOR SWITCHES Ø 6,35 (1/4) - ALL SERIES

HEX NUT	LOCKING RING	LOCKWASHER
<p>8.00 (.314) 1.60 (.062) Ø6.35-40UNS (1/4-40UNS)</p>	<p>Ø9.60 (.377 DIA) 5.20 (.204) Ø6.50 (.255 DIA) 2.00 (.078) 0.80 (.031)</p>	<p>Ø9.50 (.374 DIA) 0.80 (.031) Ø6.50 (.255 DIA) 0.40 (.015)</p>
Nickel plated Matt black	Nickel plated Matt black	Stainless steel
U76 U94	U78 U93	U215

HARDWARE SUPPLIED (unsealed types)

SERIES	HEX NUT	LOCKING RING	LOCKWASHER
SF	2	1	1
11000	2	1	1
13000	2	1	1
18000-8000-SP	2	1	1
21000N	2	-	-
5000	2	1	1
9400-9600	2	-	-

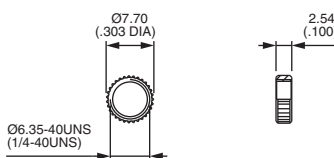
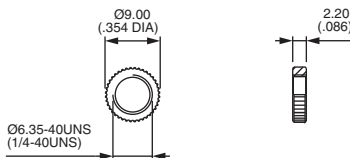
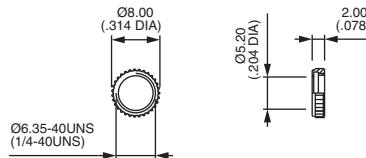
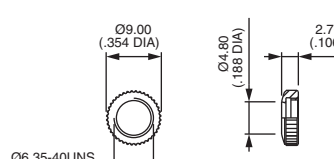
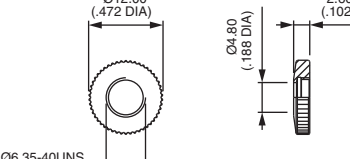
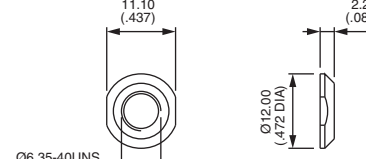

NON STANDARD HARDWARE FOR SWITCHES Ø 6,35 (1/4) - ALL SERIES

<p>KNURLED NUT</p>  <p>Nickel plated U369</p>	<p>KNURLED NUT</p>  <p>Nickel plated U229 Matt black U230</p>	<p>KNURLED NUT</p>  <p>Chrome plated U501</p>
<p>KNURLED CAP NUT</p>  <p>Chrome plated U216 Matt black U218</p>	<p>KNURLED CAP NUT</p>  <p>Chrome plated U268 Matt black U725</p>	<p>DRESS NUT</p>  <p>Nickel plated U443 Matt black U848</p>

* U216 and U268 : consult factory for mounting on 11000 three and four pole, and 5000 locking lever models.

OTHER HARDWARE FOR SWITCHES Ø 6,35 (1/4) - ALL SERIES

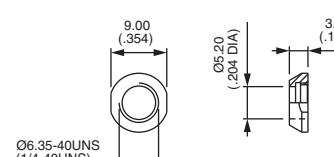
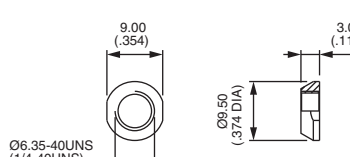
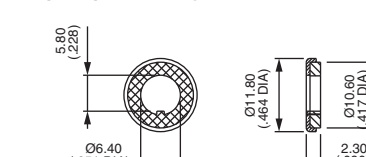
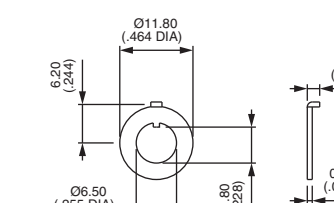
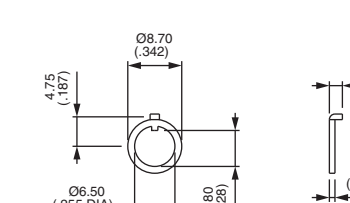
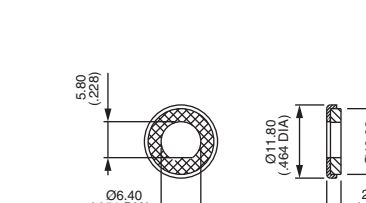
<p>CONIC CAP NUT</p>  <p>Nickel plated U500</p>	<p>CONIC NUT</p>  <p>Chrome plated U542 Nickel plated U561</p>	<p>SEALING WASHER for keyway bushing</p>  <p>U360</p>
<p>SPECIAL LOCKING RING Spacing 6,2 mm (.244)</p>  <p>Nickel plated U368</p>	<p>SPECIAL LOCKING RING Spacing 4,75 mm (.187)</p>  <p>Nickel plated U409</p>	<p>SEALING WASHER for flatted bushing</p>  <p>U5141</p> <p>ERMEC www.ermec.com</p>

Hardware

ermec@ermec.com

For miniature switches

STANDARD HARDWARE FOR SWITCHES Ø 10 (.393) - 10400 AND 10600 SERIES

KNURLED CAP NUT
(std for 10600)

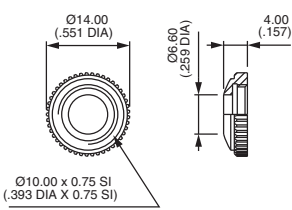

Chrome plated
U2220

KNURLED NUT
(std for 10400)

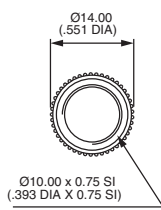

Nickel plated
U2311

HEX NUT

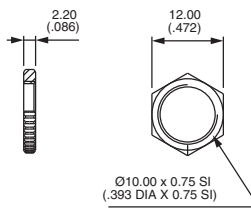

Nickel plated
U842

LOCKING RING

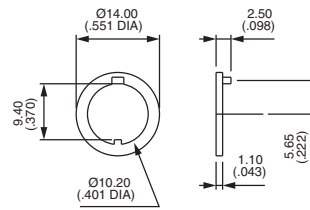

Nickel plated
U844

LOCKWASHER

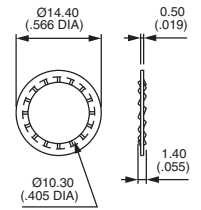

Zinc plated steel
U843

STANDARD HARDWARE FOR SWITCHES Ø 11,9 (15/32) - 12000, 13000X768 AND 5600M SERIES

HEX NUT

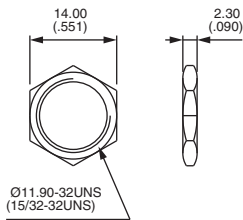

Nickel plated
Matt black
U162
U41

LOCKING RING

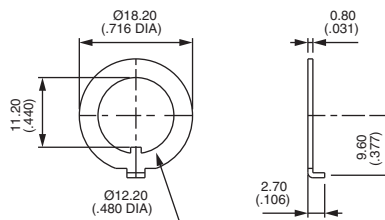

Nickel plated
Matt black
U121
U12

SERIES	HARDWARE SUPPLIED	
	HEX NUT	LOCKING RING
12000	2	1
13000X768	1	-
5600M	2	1
8000X718	2	1

NON STANDARD HARDWARE FOR SWITCHES Ø 11,9 (15/32) - 12000, 13000X768 AND 5600M SERIES

KNURLED NUT

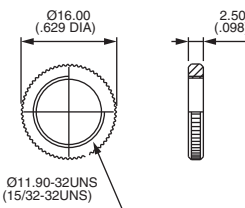

Nickel plated
Matt black
U53
U1634

KNURLED CAP NUTS

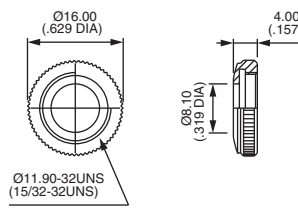

Chrome plated
U124

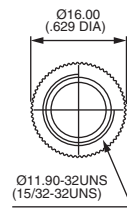

Chrome plated
U123

LOCKWASHER

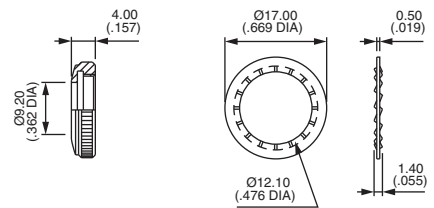

Zinc plated steel
U13

HARDWARE FOR SWITCHES Ø 16

KNURLED NUT

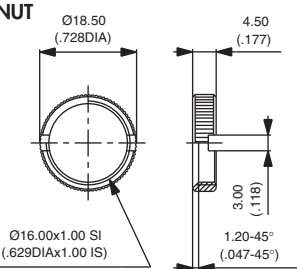

U3327

OTHER HARDWARE

SEALING WASHER

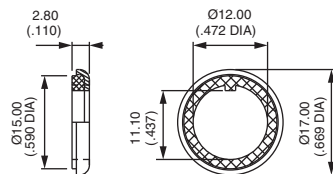

U60

WRENCHES

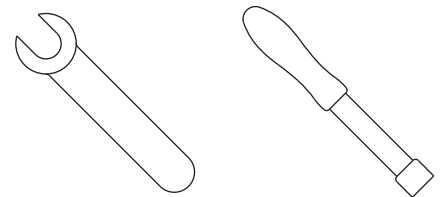

Available for accessories.
Consult **ERMEC**
www.ermec.com

www.ermec.com

- Standard hardware is indicated by darkened boxes.
For details of hardware supplied, please refer to beginning of each series.
- Special hardware is to be ordered separately.

NUTS	Bushing Ø 11,9 (15/32) thread 0,794-32UNS Series 3500 - 6000			Bushing Ø 12 (.472) thread 0,75 Series IB/IS - IP - 660 - 600H - 600NH 1000 - 1200 - 1500 - 1600 - 1700 - 3600 - 4000		
	Chrome plated brass	Nickel plated brass	Matt black brass	Chrome plated brass	Nickel plated brass	Matt black brass
		U53	U1634	U412	U411	U413
	U92	U162	U41	U212	U166	U183
				U35		
					U42 (passive zinc plated steel)	
	U123			U117 $\alpha = 8,5 (.334)$ U118 $\alpha = 10,3 (.405)$		U129 $\alpha = 8,5 (.334)$ U130 $\alpha = 10,3 (.405)$

INSULATED NUT U520

	For threaded bushing Ø 12 (.472) x 0,75 IS Series 1500 - 4000 - 600NH - 6-600NH								
	Blue	Black	Green	Grey	Yellow	Red	White	Chrome plated	Orange
	ABS or polyamide with glass fibre	U521	U522	U523	U524	U525	U526	U527/1	U528

The locking ring U121 (nickel plated) or U12 (matt black) is only provided with tropicalized switches version T or G and with series 3500 - 6000.

The lockwasher U13 must be ordered separately, except for series 660, 3500 and 6000.



HARDWARE FOR SWITCHES Ø 12 (.472) AND 11,9 (15/32)

LOCKING RING

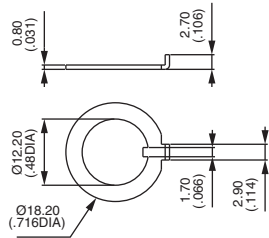

Nickel plated **U121**
Matt black **U12**

LOCKWASHER

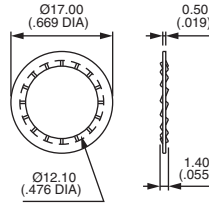

Zinc plated steel **U13**

SEALING WASHER

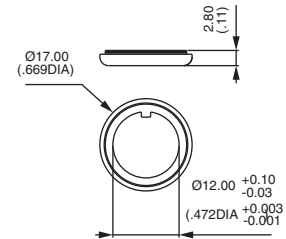

Stainless steel and neoprene **U60**

SEALING WASHER FOR BOOTS

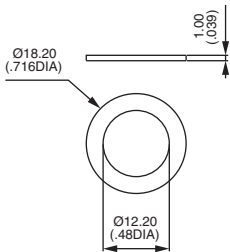

Nylon **U21**

GROUND CONNECTOR

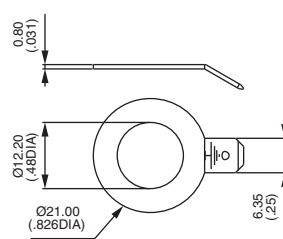

Nickel plated **U187**

LOCKWASHER

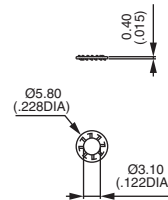

Zinc plated steel **U14**

PLATES FOR SWITCHES Ø 12 (.472) AND 11,9 (15/32)

Marche - arrêt

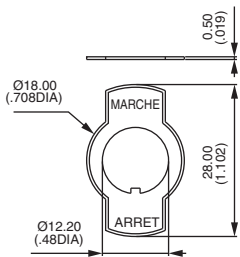

U17

ON - OFF

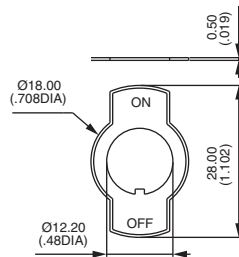

U19

EIN - AUS

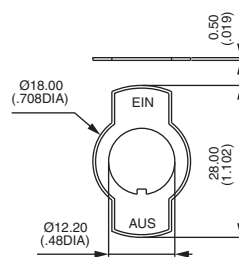

U99

I - 0

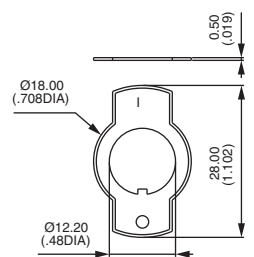

U1050

CONNECTING SCREW

Supplied with the switches

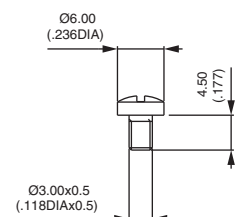

U03

ERMEC

www.ermec.com

www.ermec.com

HARDWARE FOR AV SERIES (ANTI-VANDAL AND SECURITY PUSHBUTTON SWITCHES)

HEX NUT FOR MODELS Ø 16 (.629)

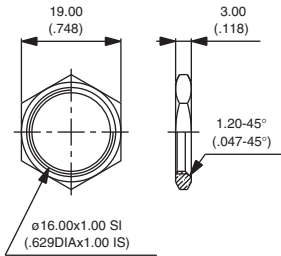

10-621 (sealed or unsealed models)

KNURLED NUT FOR MODELS Ø 16 (.629)

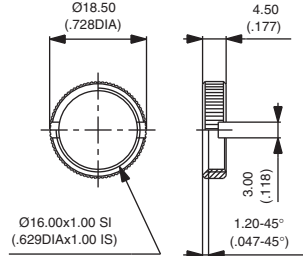

10-960-5 (sealed or unsealed models)

KNURLED NUT FOR MODELS Ø 19 (.748)

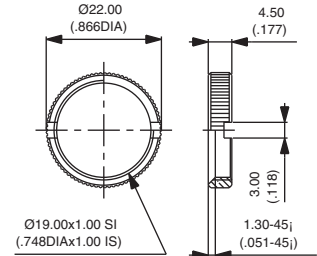

U1977-5 (sealed or unsealed models)

HEX NUTS FOR MODELS Ø 19 (.748)

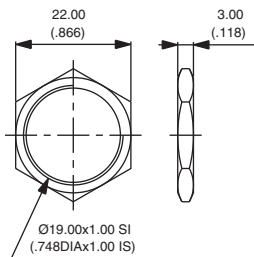

U1950-5 (unsealed models)

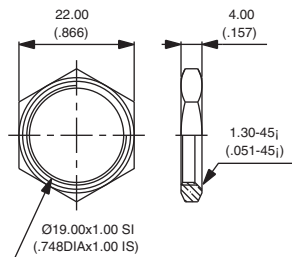

10-855-5 (sealed models)

Wrench for nut U1977-5 available under part number U1929.

HEX NUTS FOR MODELS Ø 22 (.866)

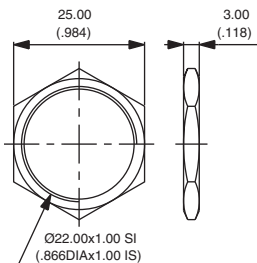

U1951-5 (unsealed models)

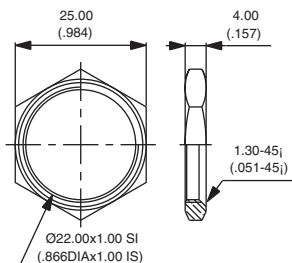

10-856-5 (sealed models)

HEX NUT FOR MODELS Ø 24 (.944)

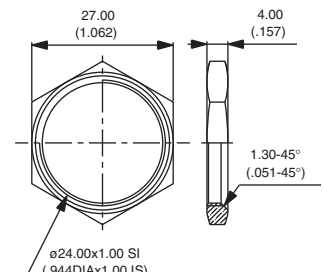

U2059-5 (sealed or unsealed models)

All above nuts are made of nickel plated brass.
For switches with front panel sealing (option K), a neoprene O-ring is supplied with each nut.