

# APEM

## LPI series

Tactile pushbutton switches with large actuator

- Front or rear mounting
- Illuminated or non-illuminated
- Flexibility of marking
- Meeting the requirements of EN81-70



Ø 35 mm  
actuator

**ERMEC**

[www.ermec.com](http://www.ermec.com)

Distribución de componentes  
eléctricos y electrónicos

Tel.: (+34) 902 450 160

Fax: (+34) 902 433 088

[ermec@ermec.com](mailto:ermec@ermec.com)

[www.ermec.com](http://www.ermec.com)

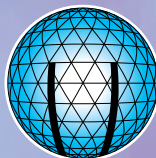

A P E M

#### ❑ Common features

- Large ergonomic actuator (Ø 35 mm)
- Tactile feedback
- Low behind-panel depth (21 mm max.)
- Stylish design
- Long life

This series has been developed on a modular base in order to fit the exact needs of technicians and end-users.

#### ❑ Installation options

The LPI series has a number of features to ensure easy installation:

- Front or rear mounting
- With or without sealing
- 2 separate circuits for NO/NC 5A version
- Terminal block connector for 0,1A NO version
- 3 different LED voltages: 6V, 12V, 24V
- Integrated LED resistor

#### ❑ Aesthetic options

- Ring or dot illumination
- Wide range of LED colours
- Wide range of bezel colours
- Many different actuator types and colours

#### ❑ Applications

Because of its large actuator, this product is suited to all indoor applications where the pushbutton needs to be located quickly (access control, call information, museums, exhibitions). This product is also ideal for applications where the end-user uses gloves.

This product meets the requirements of EN81-70 and is ideal for use in all types of indoor lifts.

**Dimensions** : First dimensions are in mm while inches are shown as bracketed numbers.

**Tolerance** : The general tolerance for dimensions in this brochure is  $\pm 0,3$  (.012). Overall dimension tolerance is  $\pm 0,5$  (.020).

Dimensions, specifications and data shown in this brochure are subject to change without notice.



- Front or rear mounting
- Illuminated or non-illuminated
- Flexibility of marking
- Designed to meet the requirements of EN81-70

#### ELECTRICAL SPECIFICATIONS

- Snap-action, momentary function
- Mechanical life : 1.000.000 cycles min. for 5A NO/NC  
5.000.000 cycles min. for 50mA NO
- Max. current/voltage rating with resistive load :

5A NO/NC version	50mA NO version
5A 12VDC - 50.000 cycles 100mA 12VDC - 1.000.000 cycles	50mA 24 VDC - 5.000.000 cycles

- Min. current with resistive load : 0,5mA at 24VDC for NO version
- Contact resistance : 100mΩ max.
- Dielectric strength : 500Vrms 50Hz between terminals  
1.000 Vrms 50 Hz between terminals and ground
- Insulation resistance : 10MΩ at 500VDC
- Integrated resistors for illuminated versions
- LED current : 20mA typical for dot or ring (30mA max.)
- LED protected from reverse polarity
- Stand-by consumption : 0,5VA max.

#### MATERIALS

- Switch block : thermoplastic for 5A NO/NC
- Contacts :  
5A NO/NC : silver, gold plated  
50mA NO : silver
- Actuator crimped symbol : 304L stainless steel

#### MECHANICAL SPECIFICATIONS

- Environmental protection :  
- IP53 for sealed version  
- IP40 for unsealed version
- Impact resistance :  
- IK06 for NO/NC version  
- IK04 for NO version
- Operating force : 2,5 to 5N (unsealed)
- Total travel : 2 mm ±0,3 mm
- Operating temperature :  
- 20°C to +65°C
- Storage temperature :  
- 40°C to +70°C

#### PANEL CUT-OUT

Panel thickness : 1 to 4 mm (.039 to .157)

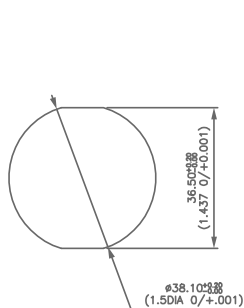

Front mounting

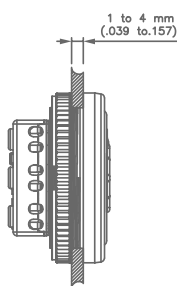

Rear mounting

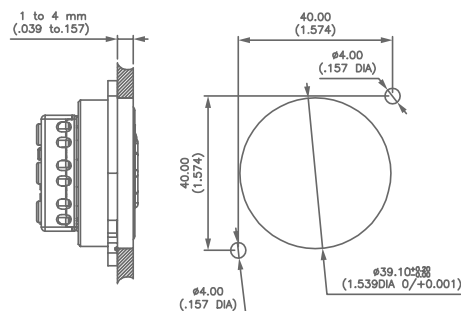

Sealed version

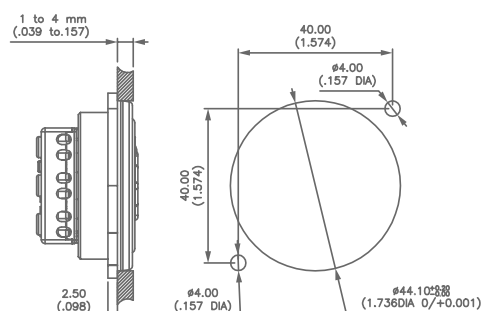

Unsealed version

### SWITCH BLOCK

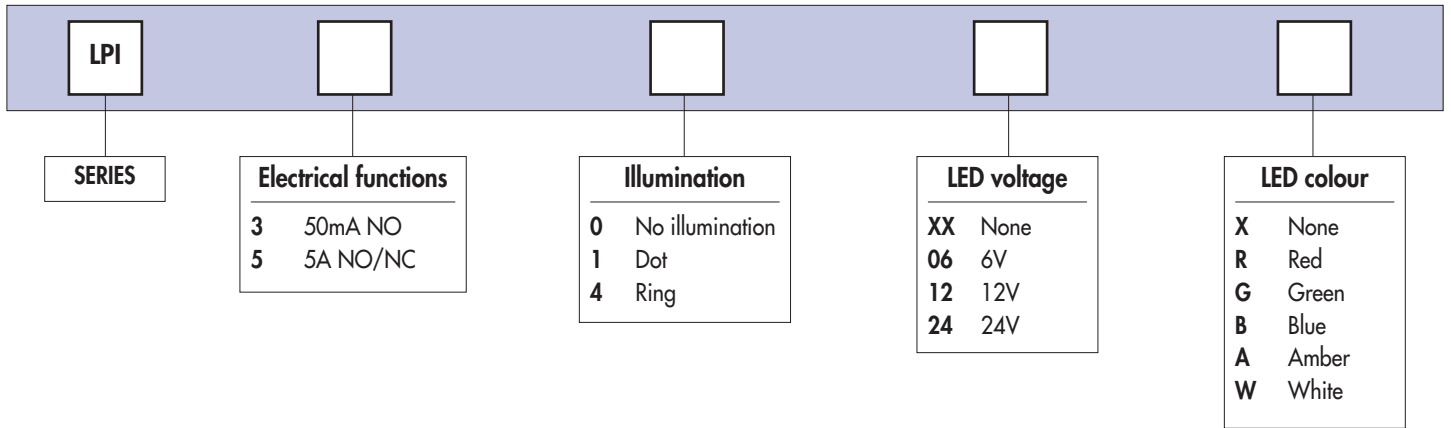

### OPERATOR

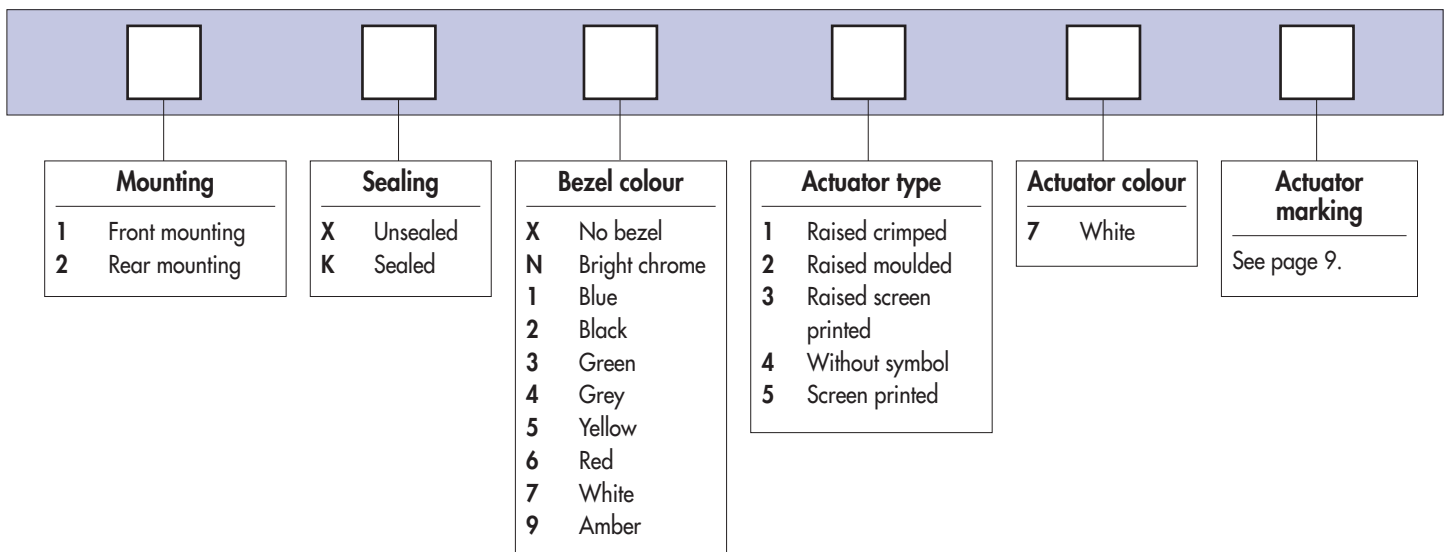

#### ABOUT THIS SERIES

On the following pages, you will find successively switch block order numbers and operator order numbers.



**NOTICE** : please note that not all combinations of above numbers are available. Refer to the following pages for further information.



**Packaging unit** : 15 pieces for front mounting versions - 20 pieces for rear mounting versions.

SWITCH BLOCK

MODEL  
STRUCTURE

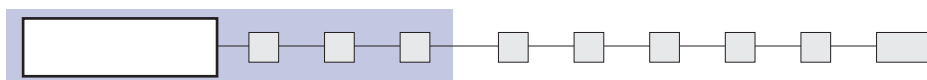

### 5A momentary NC/NO combined

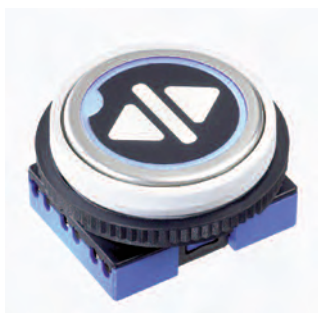

LPI5

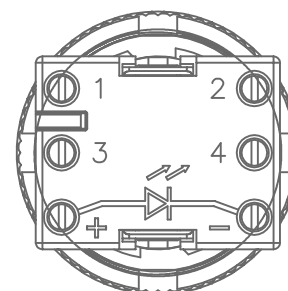
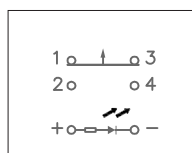

**Terminal block**

Wire size : AWG20-15 - 0,5 to 1,5 mm<sup>2</sup>

Rated torque : 0,5 Nm

Screw size : M3

### 50mA momentary NO



LPI3

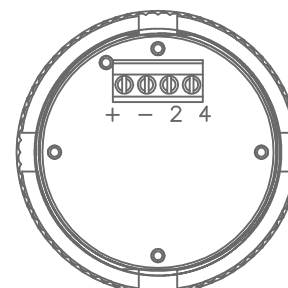
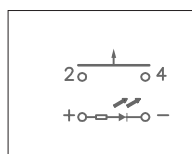

**Terminal block**

Wire size : AWG28-16 - 0,5 to 1 mm<sup>2</sup>

Rated torque : 0,4 Nm

Screw size : M2

#### ILLUMINATION

SWITCH BLOCK

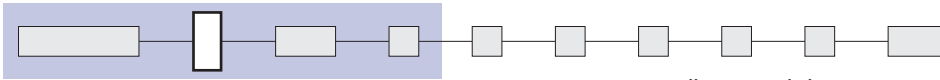

- 0 Non-illuminated
- 1 Illuminated dot (1 LED)
- 4 Illuminated ring (4 LEDs)

Option 4 available only in the case of screen-printed symbol

Illuminated dot



Option 1

Illuminated ring



Option 4

#### LED VOLTAGE

SWITCH BLOCK

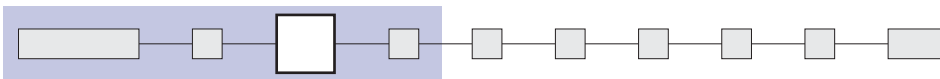

- XX Non-illuminated
- 06 6V
- 12 12V
- 24 24V



Combination with other options : see table below.

- Integrated resistors
- LED current : 20mA typical for dot or ring (30mA max.)
- LEDs protected from reverse polarity
- Stand-by consumption for illuminated product : 0,5VA max.

#### LED COLOUR

SWITCH BLOCK

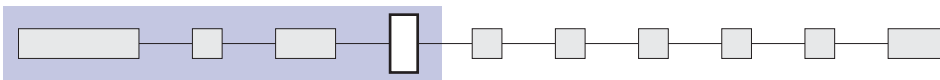

- X Non-illuminated
- R Red
- G Green
- A Amber
- B Blue
- W White

**Colours available with illuminated ring (option 4)**

		Red	Green	Amber	Blue	White
LED voltage		<b>Version 5A</b>				
6V		No	No	No	No	No
12V		Yes	Yes	No	No	No
24V		Yes	Yes	Yes	Yes	No
LED voltage		<b>Version 50mA</b>				
6V		No	No	No	No	No
12V		Yes	No	Yes	No	No
24V		Yes	Yes	Yes	Yes	No

### MOUNTING

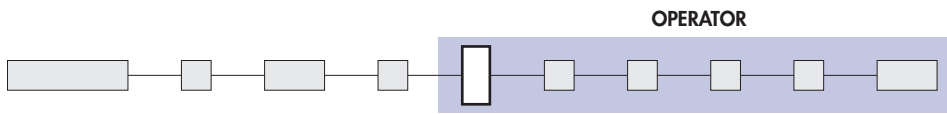

- 1 Front mounting
- 2 Rear mounting

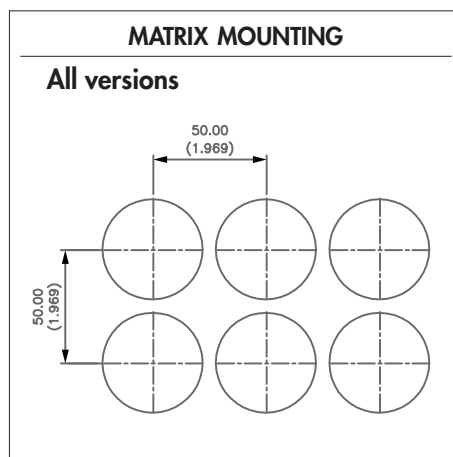
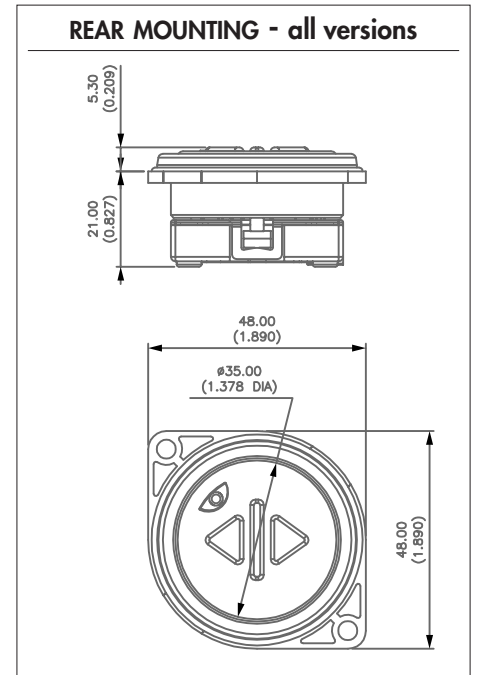
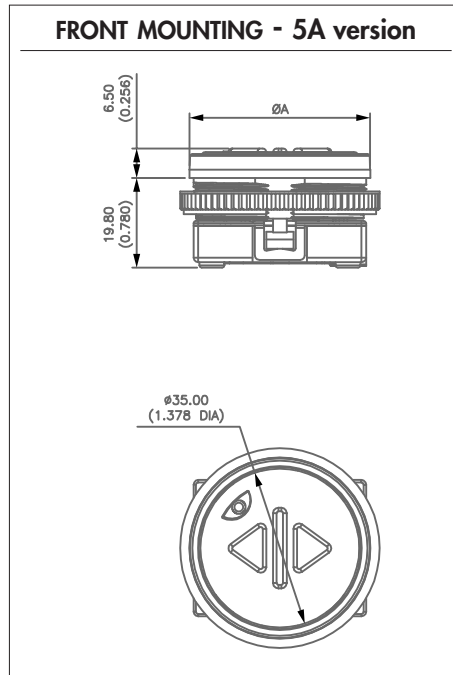
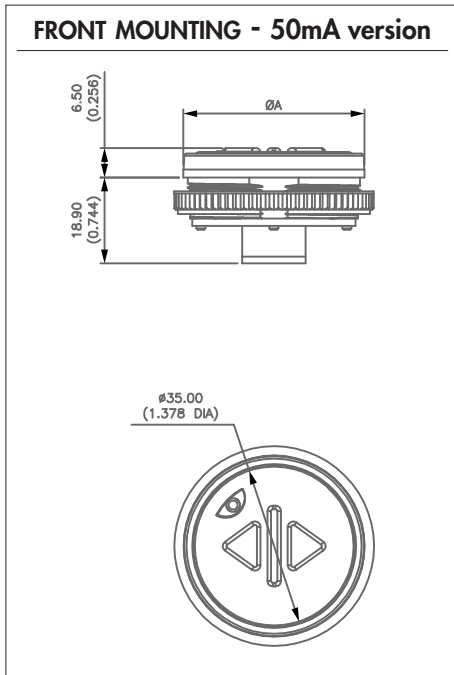

#### Dimension A

Sealed models : 44 mm (1.732)

Unsealed models : 39,9 mm (1.570)

### SEALING

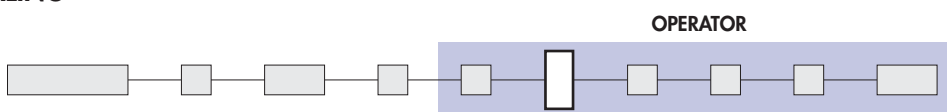

- X Unsealed
- K Sealed

Note : bezel compulsory on sealed versions.

#### BEZEL COLOUR

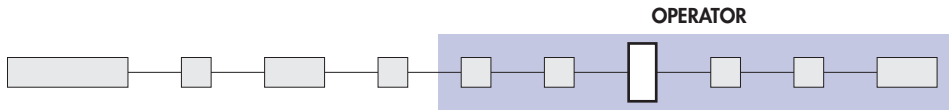

- X No bezel
- N Bright chrome
- 1 Blue
- 2 Black
- 3 Green
- 4 Grey
- 5 Yellow
- 6 Red
- 7 White
- 9 Orange

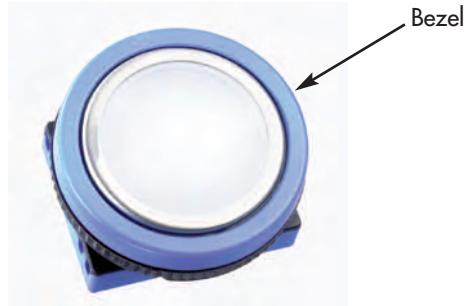

For sealed versions, the bezel is compulsory  
For unsealed versions, the bezel is optional on rear mounting versions (not available on front mounting versions).

Bright chrome (option N) : consult us.

#### ACTUATOR TYPE

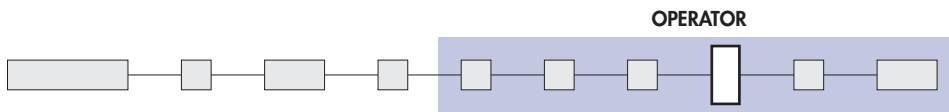

- 1 Stainless steel raised crimped symbol
- 2 Raised moulded symbol (star and bell)
- 3 Raised screen printed symbol
- 4 Without symbol
- 5 Screen printed symbol

Ring illumination available with options 3 and 4 only.

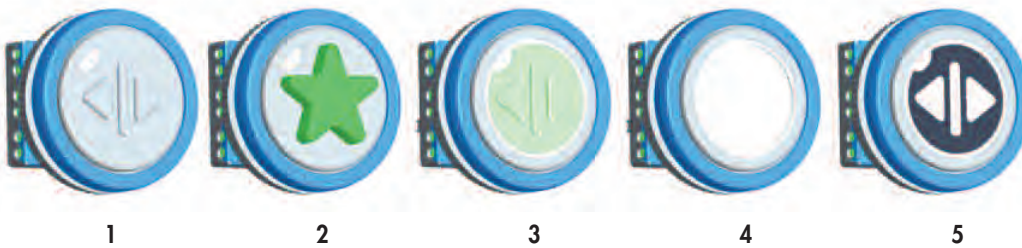

#### ACTUATOR COLOR

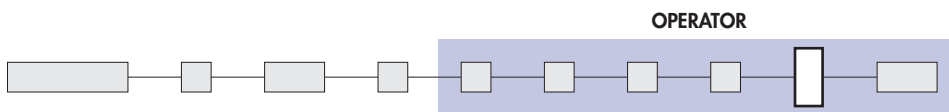

- 7 White

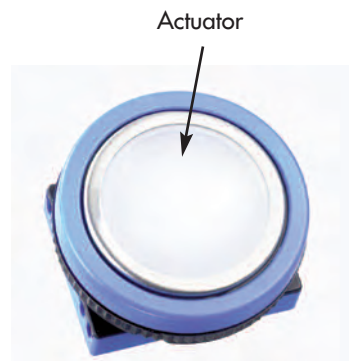

#### ACTUATOR MARKING

#### OPERATOR

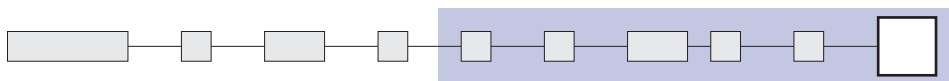

CODE	SYMBOL	DESCRIPTION
XX	/	No symbol
00	0	
01	1	
02	2	
03	3	
04	4	
05	5•	With single tactile point
06	6	
07	7	
08	8	
09	9	
10		
11	-1	
12	-2	
13	-3	

CODE	SYMBOL	DESCRIPTION
14	◀▶	Open
15	▶◀	Close
16	△	Up
17	▽	Down
18	◁	Left
19	▷	Right
20	✻	Ventilation
21	🔔	Alarm (moulded, yellow)
22	★	Exit level (moulded, green)
23	☎	Phone

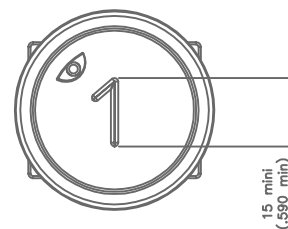
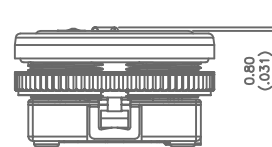

Actuator type 1

	Symbol height		
	Symbol 21	Symbol 22	Other symbol
Actuator type 1	x	x	0,8 mm
Actuator type 2	5 mm	5 mm	x
Actuator type 3	x	x	0,8 mm
Actuator type 4	x	x	x
Actuator type 5	x	x	0 mm

x = non available

# APEM, a world of switching capabilities

The APEM group is one of the world's largest manufacturers of switches, switch panels and joysticks.

APEM designs, develops, manufactures and sells electro-mechanical components to multiple industrial markets including: instrumentation, medical, security, communications, industrial automation, avionics, military and transport.

## Matching products

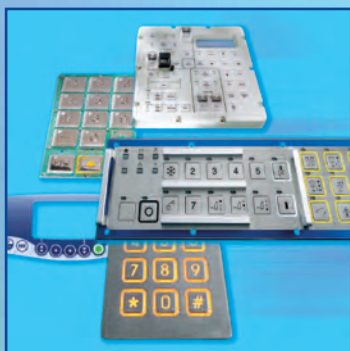

### ■ Switch panels

APEM offers several switch panel technologies suitable for automotive, industrial, vending, military and other professional custom applications. APEM has expertise in designing and manufacturing membrane switch panels, stainless steel keyboards and complete custom interfaces incorporating backlighting, electroluminescence, EMC protection and associated electronics



### ■ LED indicators

The Q series panel mount LED indicators complement the APEM range of products. This series comprises seven different diameters, from 6 mm to 22 mm. They are available with prominent, recessed and flush bezel styles, different bezel finishes, five LED colours, as well as bicolour, tricolour and flashing LEDs. Integral resistors permit direct connection to 12VDC, 24VDC, 110VAC and 230VAC. APEM also manufactures special DDA-compliant yellow LED indicators.



[www.ermec.com](http://www.ermec.com)

Distribución de componentes  
eléctricos y electrónicos

Tel.: (+34) 902 450 160

Fax: (+34) 902 433 088

[ermec@ermec.com](mailto:ermec@ermec.com)

[www.ermec.com](http://www.ermec.com)



A P E M

Addresses of sales subsidiaries and distributors network on  
[www.apem.com](http://www.apem.com)