



an APEM Group Company



TS series

Hall effect miniature proportional joystick



The TS Series Thumbstick is a proportional two axes joystick in a miniature package. Featuring non-contacting Hall effect technology for long life performance, the TS Series Thumbstick is available with multiple linear output options including single and dual (redundant) outputs. It is similar in size and operation to “gamepad” controls, but in a rugged industrial package. Typical applications include pendant and remote controls as well as joystick handle and arm rest integration.



KEY FEATURES

- 1 or 2 axes
- Non-contact Hall effect technology
- Submersible to 1m (3.28ft) per IP68
- Pressure washable to IP69K
- Redundant outputs available
- Rear or drop-in mounting available



TS series

Hall effect miniature proportional joystick

OPTION SELECTION



Distribución de componentes eléctricos y electrónicos

TS						
SERIES	HANDLE	TERMINATION*	MOUNTING HARDWARE	LIMITER	OUTPUT OPTIONS	POWER SUPPLY OPTIONS
	-0 None -1 Castle -2 Winged Hat -3 Conical	1 22AWG 25cm PTFE 2 28AWG 25cm PTFE 3 Customer specified	N None D Drop-in R Rear mount	U Single axis <input type="checkbox"/> S Square <input type="checkbox"/>	00 0V to 5V (Rail to Rail) 01 0.25V to 4.75V 02 0.5V to 4.5V 03 1V to 4V 04 0V to 5V - Sensor 1 0V to 5V - Sensor 2 05 0.25V to 4.75V - Sensor 1 0.25V to 4.75V - Sensor 2 06 0.5V to 4.5V - Sensor 1 0.5V to 4.5V - Sensor 2 07 1V to 4V - Sensor 1 1V to 4V - Sensor 2 08 0V to 5V - Sensor 1 5V to 0V - Sensor 2 09 0.5V to 4.5V - Sensor 1 4.5V to 0.5V - Sensor 2 10 0.25V to 4.75V - Sensor 1 4.75V to 0.25V - Sensor 2 11 1V to 4V - Sensor 1 4V to 1V - Sensor 2 12 Customer specified 13 PWM**	A Single B Independent***

NOTES:

 Mounting accessories. Standard hardware includes:

- For the Drop-in option - 4 push in connectors, drop-in bezel and an O-ring.
- For the Rear mount option - 4 x 1/2 FH SS Phil Screws and a rear mount bezel.

* 1 - Wires are thick, robust, and best suited for stand alone applications.
2 - Wires are thin and best suited for tightly constrained wire routing.

** Contact factory for PWM configuration.

*** Only available on dual output.

SPECIFICATIONS

MECHANICAL (FOR X, Y AXES)		
Operating Force	-	3.1N±0.5N (0.70lbf±0.11lbf)
Maximum Vertical Load	-	200N (45lbf)
Maximum Horizontal Load	-	150N (33.7lbf)*
Mechanical Angle of Movement	-	±25° (50° total)
Life Cycles	-	>1 million
Mass/weight	-	18.25g ± 3.0g (0.64oz±0.11oz)
Lever Action (Centering)	-	Spring Centering

ENVIRONMENTAL		
Operating Temperature	-	-40°C to +85°C (-40°F to +185°F)
Storage Temperature	-	-40°C to +85°C (-40°F to +185°F)
Sealing	-	IP68, IP69K**
EMC Immunity Level	-	EN61000-4-3
EMC Emissions Level	-	EN61000-6-3:2001
ESD	-	EN61000-4-2

ELECTRICAL SENSOR		
Resolution	-	1.22mV
Supply Voltage Range	-	5.00V±0.01V
Reverse Polarity Max	-	-10V
Overvoltage Max	-	20V
Output Impedance	-	2Ω
Return to Center Voltage Tolerance	-	±250mV
Error Signal	-	1.0%

* Force applied to the top of the cap at full displacement.
** All options are IP68 and IP69K rated, however Drop-in mounting does not prevent panel ingress.

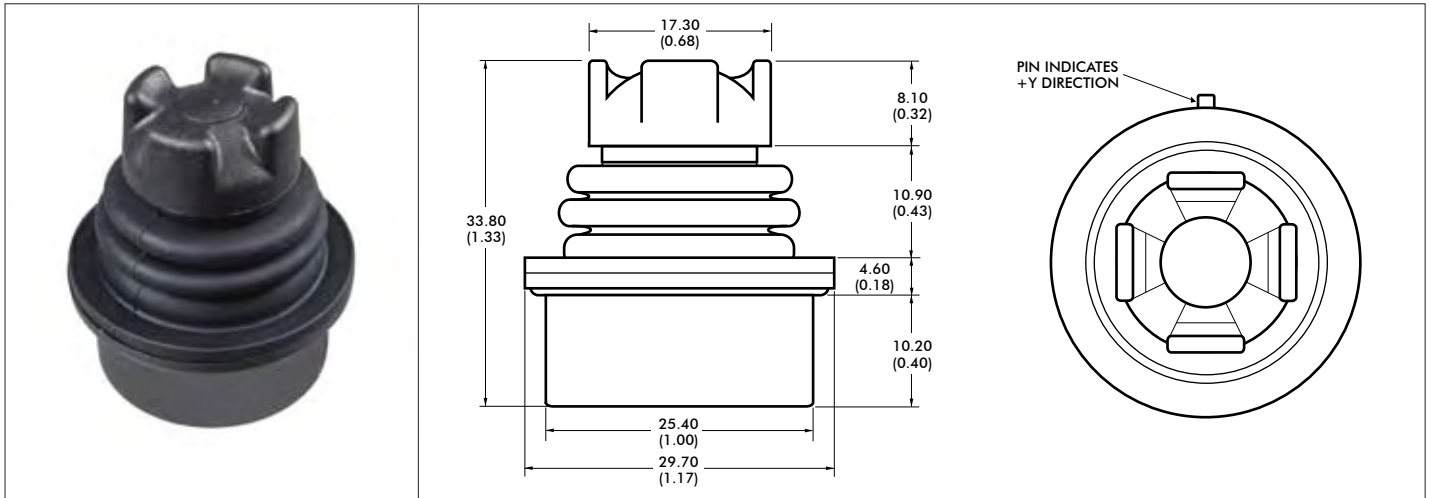

HANDLE OPTIONS

CASTLE

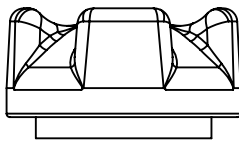

WINGED HAT

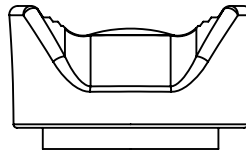

CONICAL

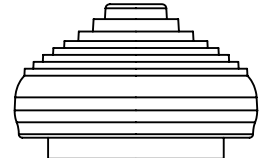

MOUNTING OPTIONS

DROP-IN OPTION CUTOUT DIMENSIONS

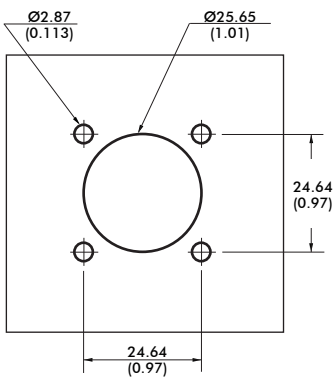

4 x PUSH IN CONNECTORS



REAR MOUNT OPTION CUTOUT DIMENSIONS

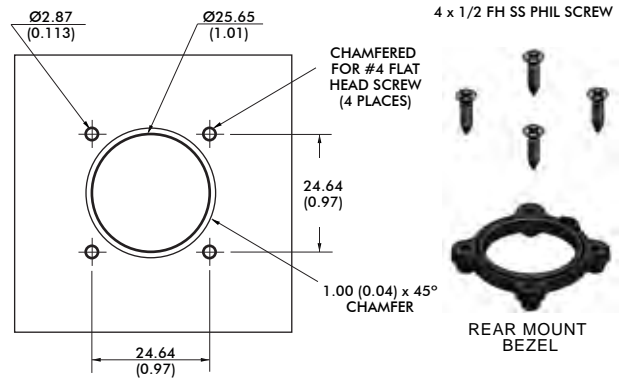

4 x 1/2 FH SS PHIL SCREW



REAR MOUNT BEZEL

Note: Maximum panel thickness is 0.32mm (0.08in)

Note: Dimensions are in mm/(inch)

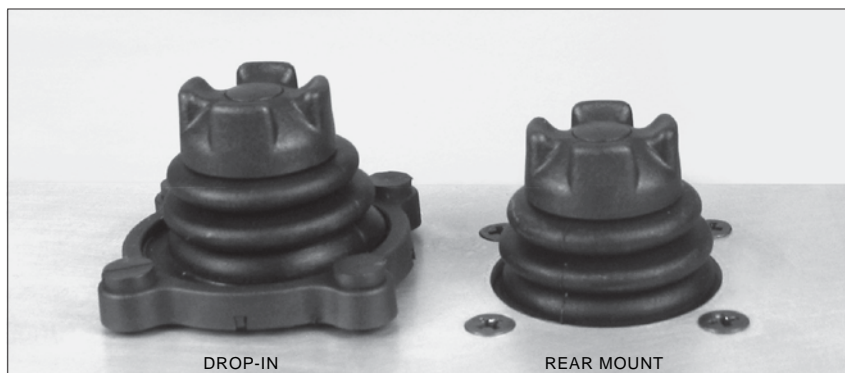

TS series

Hall effect miniature proportional joystick

CONFIGURATION OPTIONS



Distribución de componentes eléctricos y electrónicos

LINEAR OUTPUT OPTIONS

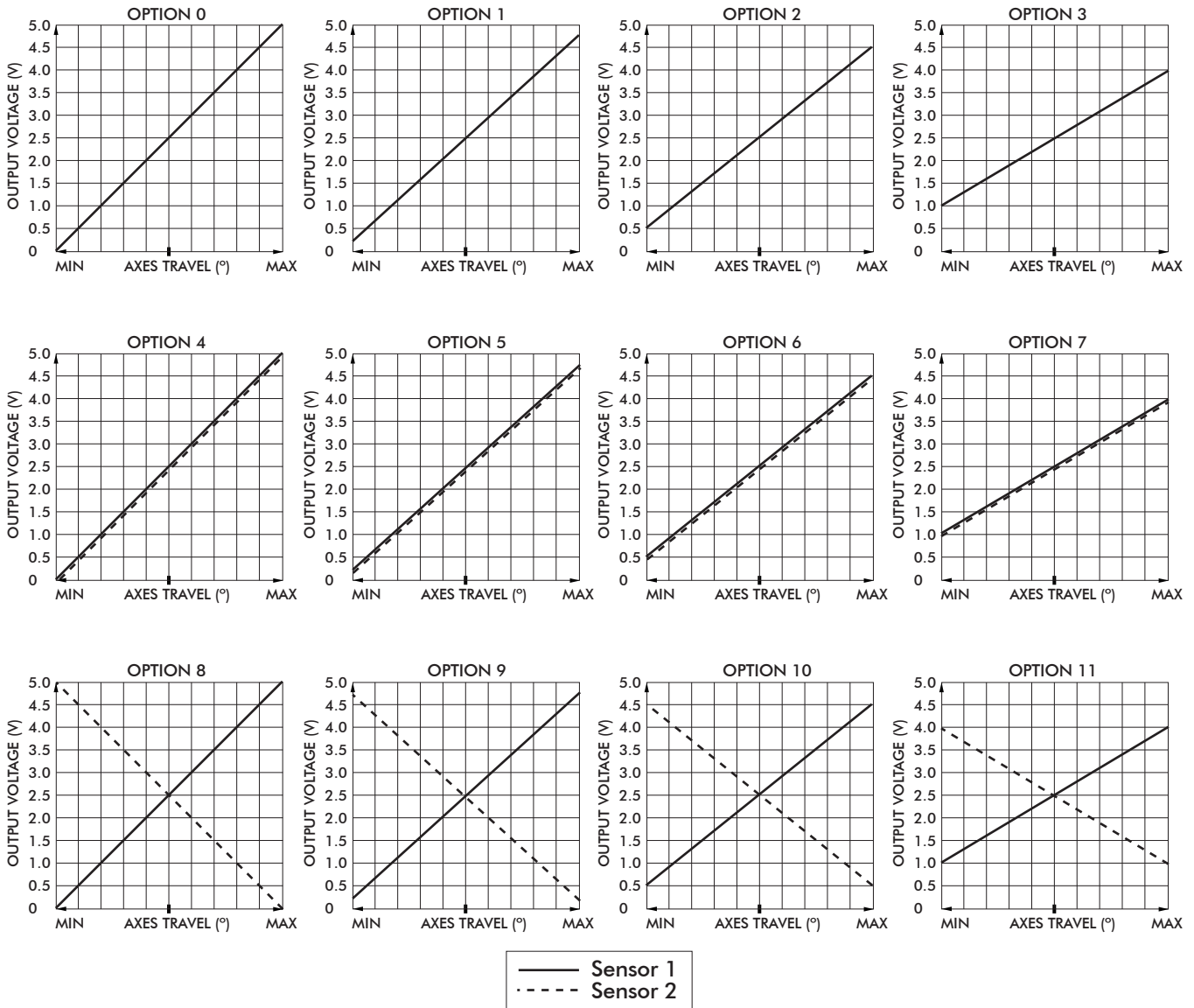

WIRING

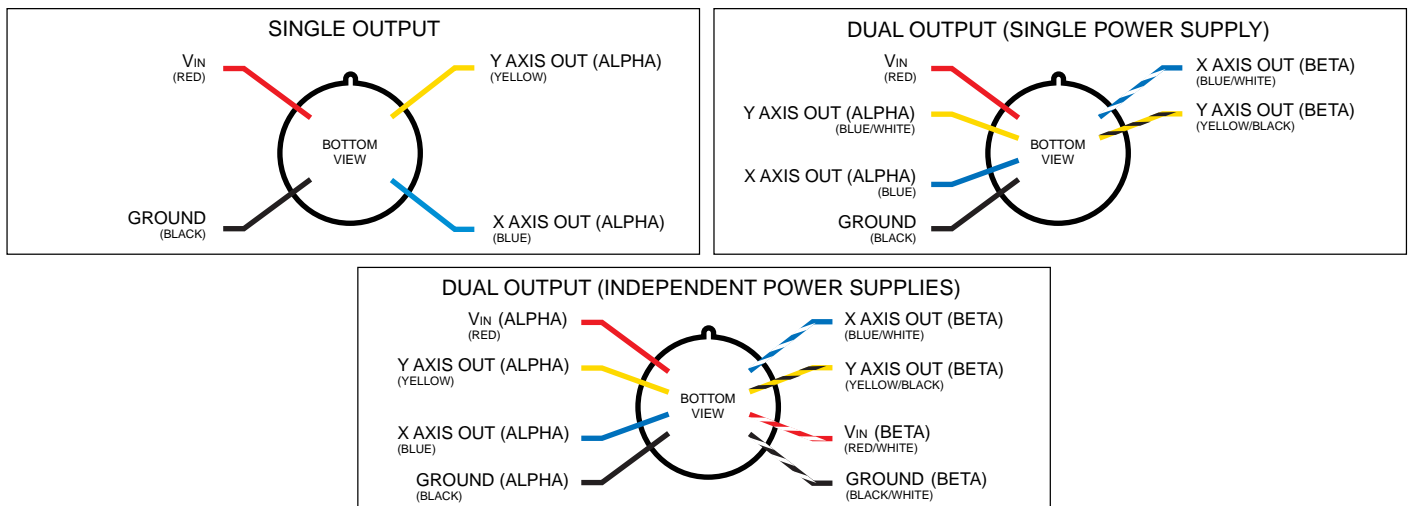

ERMEC, S.L. BARCELONA
 C/ Francesc Teixidó, 22
 E-08918 Badalona
 (Spain)

Tel.: (+34) 902 450 160
 Fax: (+34) 902 433 088
info@ermec.com
www.ermec.com

ERMEC, S.L. MADRID
 C/ Sagasta, 8, 1ª planta
 E-28004 Madrid
 (Spain)

PORTUGAL
portugal@ermec.com
 BILBAO
bilbao@ermec.com