

MicroSpeed® Power Modules

ERMEC, S.L. BARCELONA
 C/ Francesc Teixidó, 22
 E-08918 Badalona
 (Spain)

Tel.: (+34) 902 450 160
Fax: (+34) 902 433 088
info@ermec.com
www.ermec.com

ERMEC, S.L. MADRID
 C/ Sagasta, 8, 1ª planta
 E-28004 Madrid
 (Spain)

PORTUGAL
portugal@ermec.com
BILBAO
bilbao@ermec.com

www.erni.com

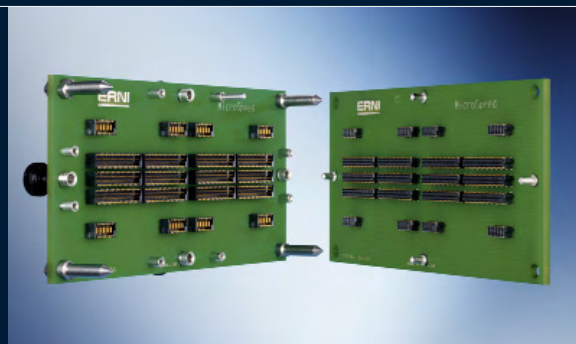
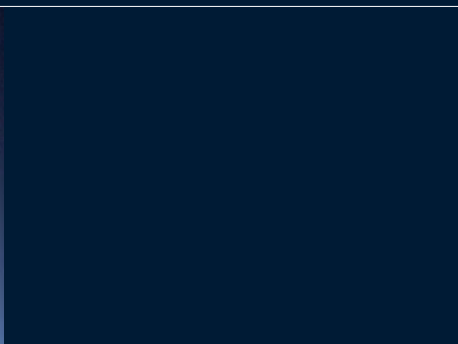
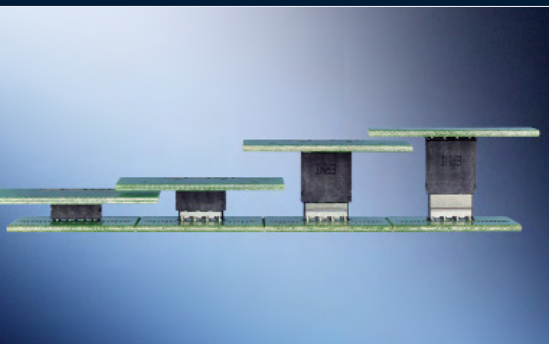

ERMEC, S.L. BARCELONA
C/ Francesc Teixidó, 22
E-08918 Badalona
(Spain)

Tel.: (+34) 902 450 160
Fax: (+34) 902 433 088
info@ermec.com
www.ermec.com

ERMEC, S.L. MADRID
C/ Sagasta, 8, 1ª planta
E-28004 Madrid
(Spain)

PORTUGAL
portugal@ermec.com
BILBAO
bilbao@ermec.com

General2
Mating Conditions3
Board-to-Board Height Configurations4
Electrical and Mechanical Characteristics5
Packaging7
Male Connectors8
Female Connectors12
Part Number Index16



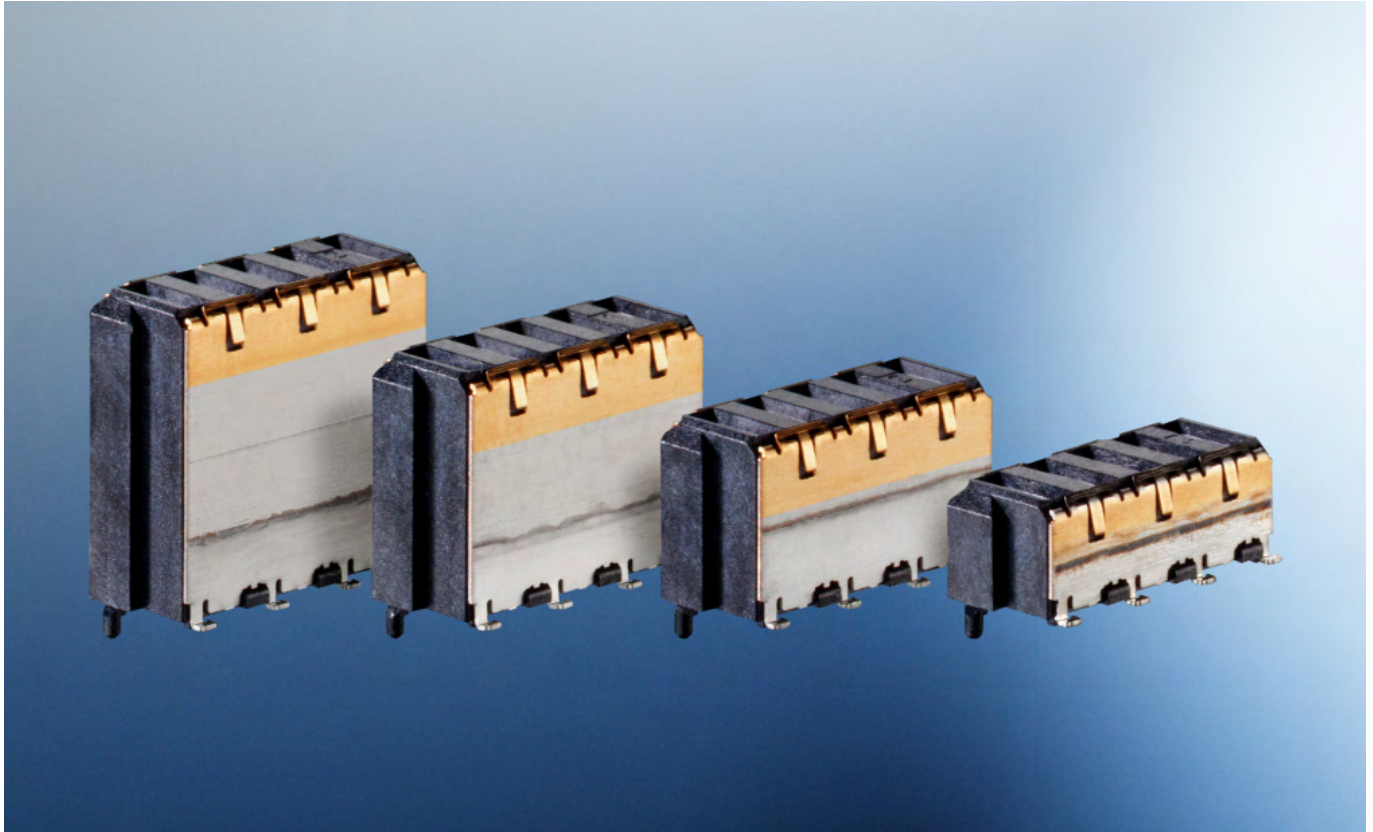

This complementary range of Power Module connectors, with 2.0 mm contact pitch, fulfils the need for miniaturized and high reliability power systems, and offers a large number of options for mezzanine applications. One of its unique features is its high current-carrying capacity in comparison to its small size. Therefore, the system is ideally suited for use with small, high performance devices such as CPUs, drives, LCD panels, etc. Providing a variety of height versions of the male and female connectors, the Power Module series enables stacking heights from 5 mm to 20 mm. Subsequently, almost every need for different PCB arrangements can be addressed. Another major advantage is the multiple-connector mating capability, which allows the mating of more than one connector pair at the same time.

The SMT connectors meet all the needs of fast automatic assembly machines. They are manufactured and 100% inline quality checked by machine to ensure high coplanarity and optimized soldering. The layout is designed with an optimal solder pad size to guarantee high retention forces. The integrated 3-point double beam female contact ensures durable low-contact resistance over the whole lifecycle.

The contacts are post plated, leaving no bare edges in the contact and solder areas. The connectors are equipped with polarized positioning pegs, and the connector plating is lead free, complying with the European RoHS directive.



Allowed misalignment tolerances longitudinal and transverse axes ± 0.7 mm

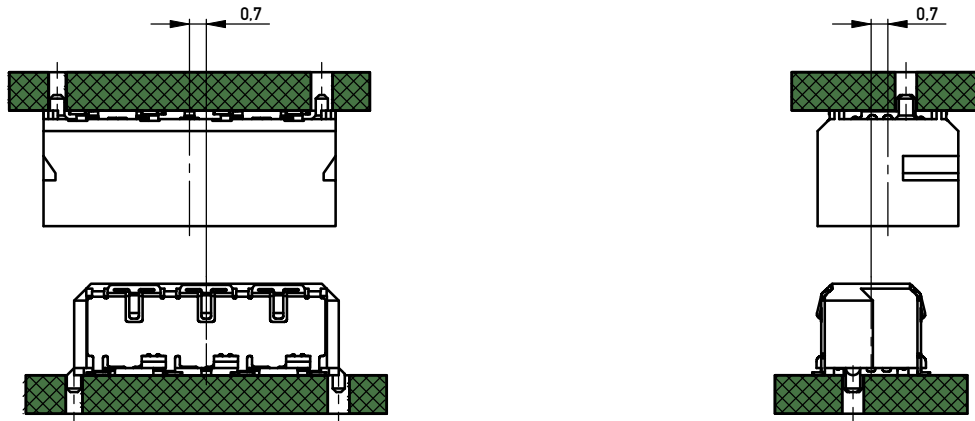

Allowed angular inclination tolerances longitudinal: $\pm 4^\circ$; transverse: $\pm 2^\circ$

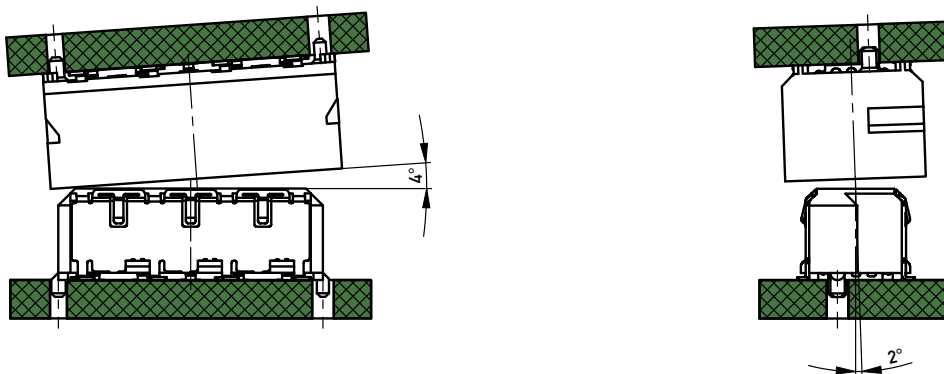

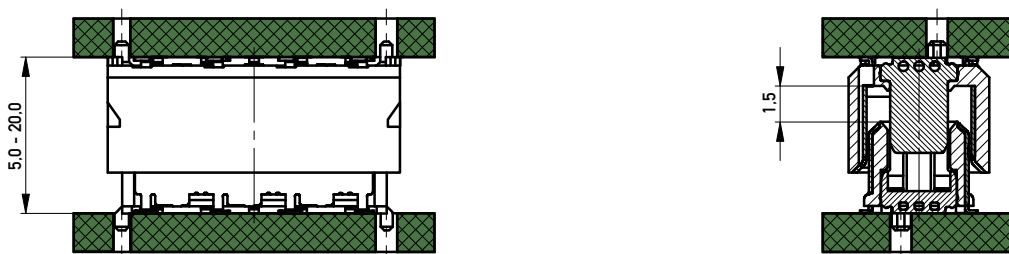

Wipe length 1.5 mm / Board-to-Board distance 5-20 mm

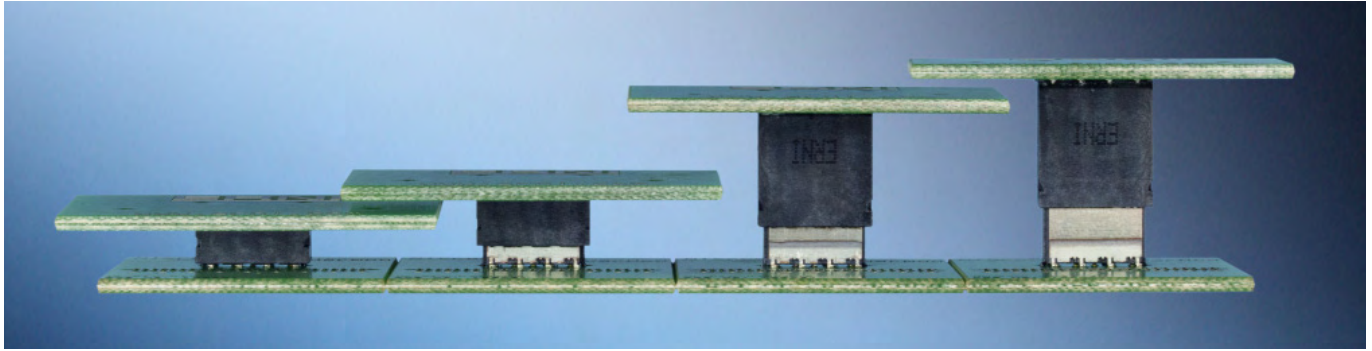

All dimensions in mm.

Board-to-Board Height Configurations

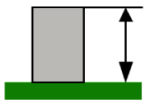

 Male			 Female			Board-to-Board Height
Height	Part Number SMD	Part Number THR	Height	Part Number SMD	Part Number THR	
1 mm	214357	214916	4 mm	214356	214912	5 mm
2 mm	214550	214917	4 mm	214356	214912	6 mm
1 mm	214357	214916	6 mm	214547	214913	7 mm
2 mm	214550	214917	6 mm	214547	214913	8 mm
1 mm	214357	214916	8 mm	214548	214914	9 mm
2 mm	214550	214917	8 mm	214548	214914	10 mm
1 mm	214357	214916	10 mm	214549	214915	11 mm
2 mm	214550	214917	10 mm	214549	214915	12 mm
9 mm	214551	214918	4 mm	214356	214912	13 mm
10 mm	214552	214919	4 mm	214356	214912	14 mm
9 mm	214551	214918	6 mm	214547	214913	15 mm
10 mm	214552	214919	6 mm	214547	214913	16 mm
9 mm	214551	214918	8 mm	214548	214914	17 mm
10 mm	214552	214919	8 mm	214548	214914	18 mm
9 mm	214551	214918	10 mm	214549	214915	19 mm
10 mm	214552	214919	10 mm	214549	214915	20 mm

www.ermec.com

	Standard	Male Connectors	Female Connectors
Number of Pins		5	5
Technical data			
Climate category	DIN EN 60068-1 test b	-55/125/56	-55/125/56
Temperature range		-55/125 °C	-55/125 °C
Current rating		20 °C	70 °C 100 °C
		per contact 6.6 A shields parallel 10.0 A	5.0 A 3.4 A 7.2 A 4.8 A
Air – and creepage distance		contact - contact 1.5 mm contact - ground 0.9 mm	contact - contact 1.5 mm contact - ground 0.9 mm
Voltage rating	IEC60664	The permissible operating voltages depend on the customer application and on the applicable or specified safety requirements. Insulation coordination according to IEC 60664-1 has to be regarded for the complete electrical device. Therefore, the maximum creepage and clearance distances of the mated connectors are specified for consideration as a part of the whole current path. In practice, reductions in creepage or clearance distances may occur due to the conductive pattern of the printed board or the wiring used, and have to be taken into account separately. As a result the creepage and clearance distances for the application may be reduced compared to those of the connector.	
Dielectric strength	IEC 60512 test 4a	contact - contact 750 V _{rms} contact - shield 750 V _{rms}	contact - contact 750 V _{rms} contact - shield 750 V _{rms}
Contact resistance	IEC 60512 test 2a	≤ 4 mΩ	≤ 4 mΩ
Insulation resistance	IEC 60512 test 3a	≥ 10 ⁴ MΩ	≥ 10 ⁴ MΩ
Vibration, sine	IEC 60512 test 6d	10 - 2000 Hz 20 g	10 - 2000 Hz 20 g
Contact disturbance (while vibration test)	IEC 60512 test 2e	≤ 1 μs	≤ 1 μs
Shock, halvesine	IEC 60512 test 6c	50 g 11 ms	50 g 11 ms
Contact disturbance (while shock test)	IEC 60512 test 2e	≤ 1μs	≤ 1μs
Mechanical operation (mating cycles)	IEC 60512 test 9a	≥ 500 mating cycles	≥ 500 mating cycles
Insertion and withdrawal force	IEC 60512 test 13b	≤ 20 N	≤ 20 N
Gauge retention force	IEC 60512 test 16e	≥ 0.5 N	≥ 0.5 N



Electrical and Mechanical Characteristics

	Standard	Male Connectors	Female Connectors
Number of Pins		5	5
Process-conditions			
Soldering temperature max.	IEC 68-2-20		
Hand soldering temperature max.		3.5 s at 350 °C	3.5 s at 350 °C
Dip soldering temperature max.		10 s at 260 °C	10 s at 260 °C
Reflow soldering temperature max.	JEDEC J-STD-020C	20 - 40 s at 260 °C	20 - 40 s at 260 °C
Coplanarity		< 0.1 mm	< 0.1 mm
Housing Materials			
Plastic material		LCP	LCP
CTI value	IEC 60112	175	175
UL flame rating		UL 94 V-0	UL 94 V-0
UL file		E83005	E83005
Contact Materials			
Base material		Cu alloy	Cu alloy
Mating area		gold plating	gold plating
Termination area		Sn	Sn
Environment compatibility			
Recycling		no flame-retardent additives, no toxic additives allows easy recycling	

Male Connectors

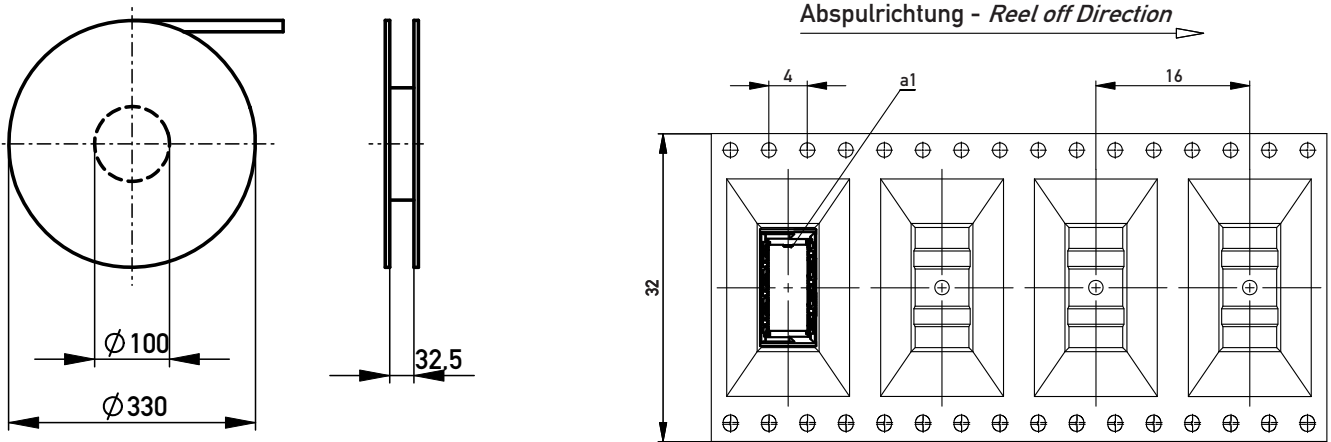

Female Connectors

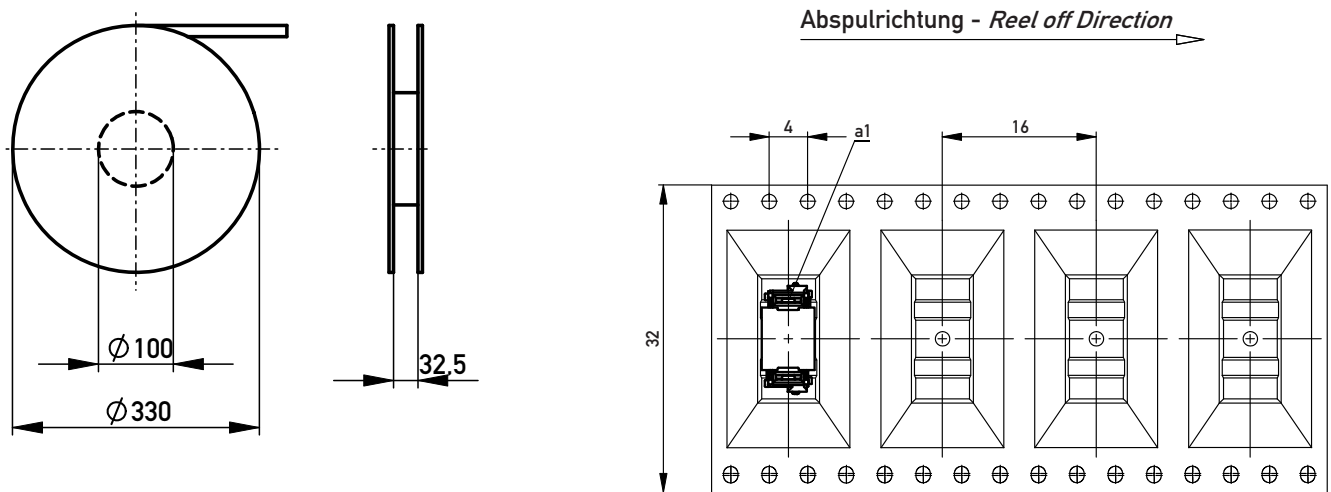

All dimensions in mm.



Male Connectors



- Current carrying capacity up to 10 A for both shields
- Current up to 6.6 A (20°) per pin
- Partial contact loading is possible
- Board-to-Board heights 5-20 mm
- Shield contacts available as SMT or THR version

Dimensional Drawing

Connectors with SMT Ground Pins

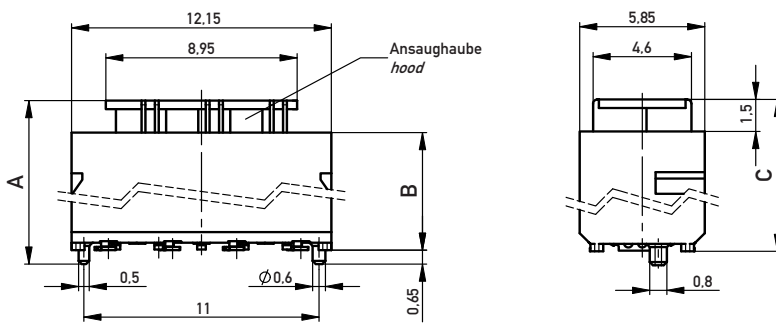

1 mm	6.95	4.80	6.30
2 mm	7.95	5.80	7.30
9 mm	14.95	12.80	14.30
10 mm	15.95	13.80	15.30
Steckhöhe Stacking Height	A	B	C

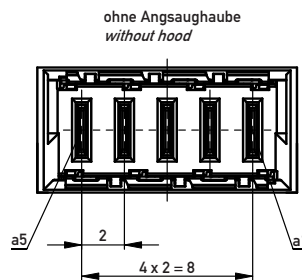
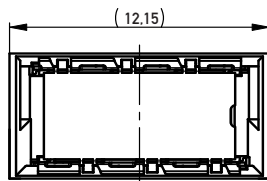

Leiterplatten-Layout / PCB-Layout

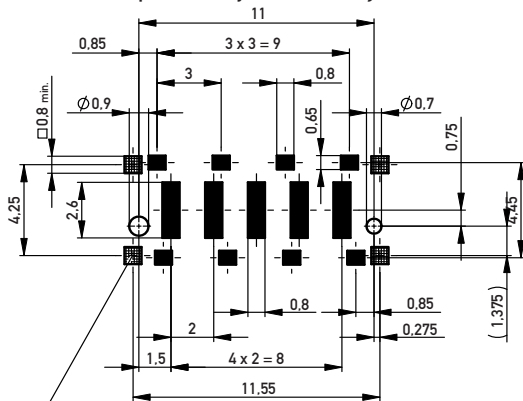





Kupferfläche für Abstandsbolzen, abgedeckt mit Lötstoplack.
Copper pads for connector standoffs, covered with solder resist.

All dimensions in mm.



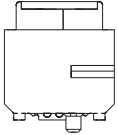
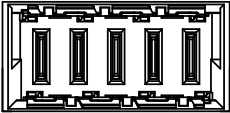
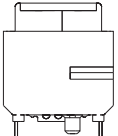

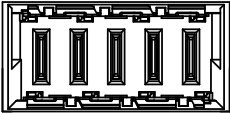

Male Connectors

Ordering Information

Number of Pins	Termination	Unmated Stacking Height	Packaging	Part Number
				
5	SMT	1 mm	Tape&Reel/420 pcs	214357
				
5	SMT/THR	1 mm	Tape&Reel/420 pcs	214916
				
5	SMT	2 mm	Tape&Reel/420 pcs	214550
				
5	SMT/THR	2 mm	Tape&Reel/420 pcs	214917

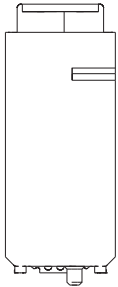
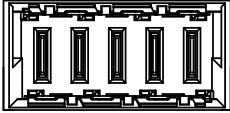
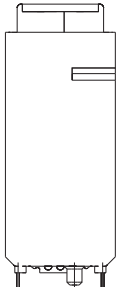
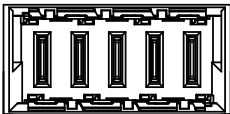
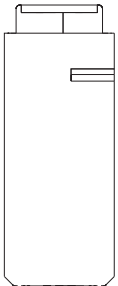

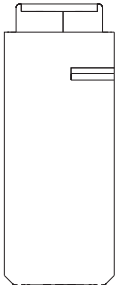
Ordering Information

Number of Pins	Termination	Unmated Stacking Height	Packaging	Part Number
				
5	SMT	9 mm	Tape&Reel/240 pcs	214551
				
5	SMT/THR	9 mm	Tape&Reel/240 pcs	214918
				
5	SMT	10 mm	Tape&Reel/240 pcs	214552
				
5	SMT/THR	10 mm	Tape&Reel/240 pcs	214919



Female Connectors

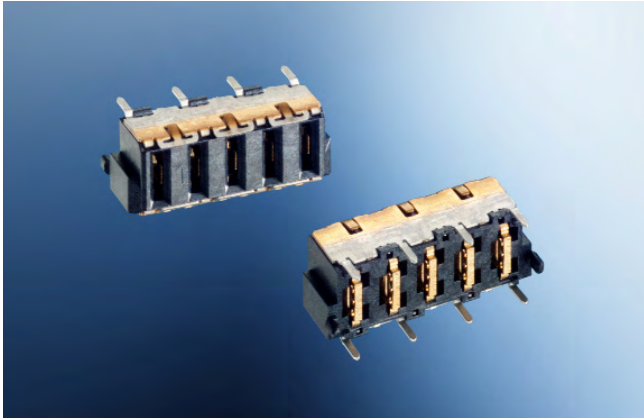

- Current carrying capacity up to 10 A for both shields
- Current up to 6.6 A (20°) per pin
- Partial contact loading is possible
- Board-to-Board heights 5-20 mm
- Shield contacts available as SMT or THR version

Dimensional Drawing

Connectors with SMT Ground Pins

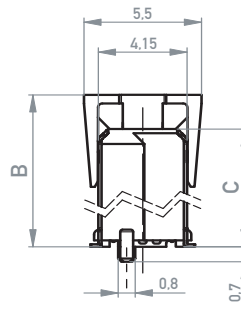
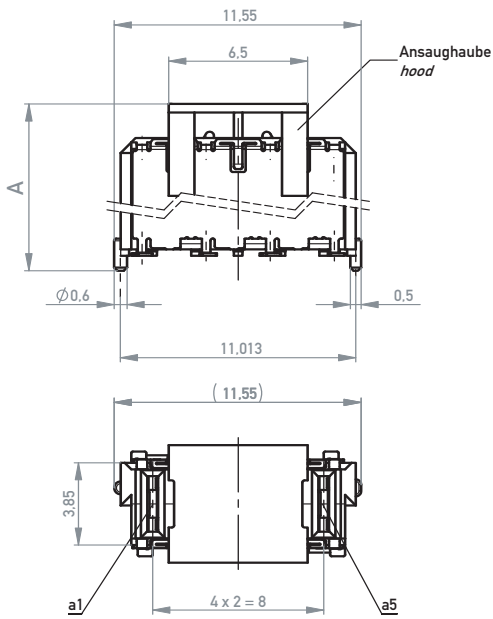

4 mm	6.10	5.40	3.80
6 mm	8.10	7.40	5.80
8 mm	10.10	9.40	7.80
10 mm	12.10	11.40	9.80
Steckhöhe Stacking Height	A	B	C

Leiterplatten-Layout / PCB-Layout

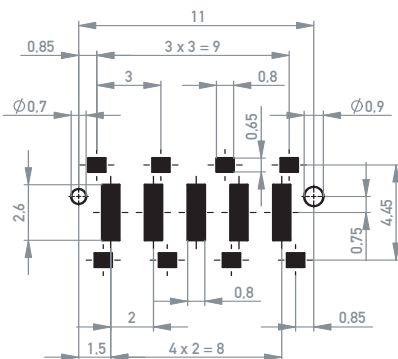

All dimensions in mm.





Female Connectors

Ordering Information

Number of Pins	Termination	Unmated Stacking Height	Packaging	Part Number
5	SMT	4 mm	Tape&Reel/420 pcs	214356
5	SMT/THR	4 mm	Tape&Reel/420 pcs	214912
5	SMT	6 mm	Tape&Reel/420 pcs	214547
5	SMT/THR	6 mm	Tape&Reel/420 pcs	214913

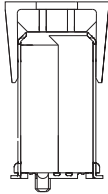
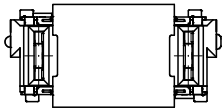
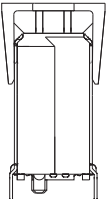

Ordering Information

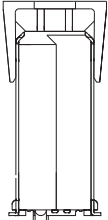
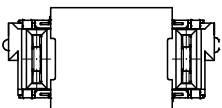
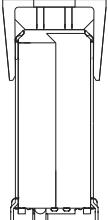
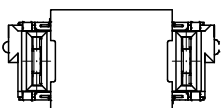
Number of Pins	Termination	Unmated Stacking Height	Packaging	Part Number
				
5	SMT	8 mm	Tape&Reel/300 pcs	214548
				
5	SMT/THR	8 mm	Tape&Reel/300 pcs	214914
				
5	SMT	10 mm	Tape&Reel/300 pcs	214549
				
5	SMT/THR	10 mm	Tape&Reel/300 pcs	214915

Part Number Index

Part Number	Page
214356	14
214357	10
214547	14
214548	15
214549	15
214550	10
214551	11
214552	11
214912	14
214913	14
214914	15
214915	15
214916	10
214917	10
214918	11
214919	11





Member



VMEbus INTERNATIONAL TRADE ASSOCIATION



ERMEC, S.L. BARCELONA
C/ Francesc Teixidó, 22
E-08918 Badalona
(Spain)

Tel.: (+34) 902 450 160
Fax: (+34) 902 433 088
info@ermec.com
www.ermec.com

ERMEC, S.L. MADRID
C/ Sagasta, 8, 1ª planta
E-28004 Madrid
(Spain)

PORTUGAL
portugal@ermec.com
BILBAO
bilbao@ermec.com

ERMEC, S.L. BARCELONA
C/ Francesc Teixidó, 22
E-08918 Badalona
(Spain)

Tel.: (+34) 902 450 160
Fax: (+34) 902 433 088
info@ermec.com
www.ermec.com

ERMEC, S.L. MADRID
C/ Sagasta, 8, 1ª planta
E-28004 Madrid
(Spain)

PORTUGAL
portugal@ermec.com
BILBAO
bilbao@ermec.com

ERNI Electronics GmbH

Seestrasse 9
73099 Adelberg, Deutschland
Tel +49 (0)71 66 50-0
Fax +49 (0)71 66 50-282
info@erni.de

Europe South America Africa Japan

ERNI Electronics, Inc.

3005 E. Boundary Terrace
Midlothian, VA 23112
Tel +1 (804) 228-4100
Fax +1 (804) 228-4099
info.usa@erni.com

North America Canada Mexico

ERNI Asia Holding Pte Ltd.

Blk 4008 Ang Mo Kio Avenue 10
#04-01/02 Techplace I
Singapore 569625
Tel +65 6 555 5885
Fax +65 6 555 5995
info@erni-asia.com

Asia

www.erni.com

© ERNI Electronics GmbH 2008 • Printed in Germany. A policy of continuous improvement is followed and the right to alter any published data without notice is reserved.
ERNI®, MicroStac®, MicroSpeed®, MiniBridge®, MaxiBridge®, ERmet®, ERmet ZD®, ERbic® and ERNIPRESS® are trademarks (registered or applied for in various countries) of ERNI Electronics GmbH.