

DORMEYER



 ERMEC, S.L. BARCELONA
C/ Francesc Teixidó, 22
E-08918 Badalona
(Spain)

Tel.: (+34) 902 450 160
Fax: (+34) 902 433 088
info@ermec.com
www.ermec.com

ERMEC, S.L. MADRID
C/ Sagasta, 8, 1ª planta
E-28004 Madrid
(Spain)

PORTUGAL
portugal@ermec.com
BILBAO
bilbao@ermec.com

 **JOHNSON
ELECTRIC**

innovating motion



The data used in this Product Overview may be used as a guideline only.
Specific operational characteristics of our products may vary according to individual applications. It is strongly recommended that specific operating conditions are clarified with Johnson Electric before application.

Johnson Electric Terms and Conditions of Sale apply.

All data may be subject to change without notice.



www.ermec.com

Tel.: (+34) 902 450 160
Fax: (+34) 902 433 088
info@ermec.com
www.ermec.com

ERMEC, S.L. MADRID
C/ Sagasta, 8, 1ª planta
E-28004 Madrid
(Spain)

PORTUGAL
portugal@ermec.com
BILBAO
bilbao@ermec.com

Table of Contents

Johnson Electric Group

About Johnson Electric	2
About Dormeyer® Solenoids	4
AC Open Frame Solenoid Overview	6
AC Laminates Overview	7
Value-Added Assemblies	8

AC Open Frame Solenoids

Open Frame Design Considerations	10
Box Frames Selection	12
B4HD	13
B11	14
B20	15
B21	16
B22	17
C Frames Selection	12
C8	18
C9	19
C15	20
C26	21
C33	22
C34	23

AC Laminates

Laminates Design Considerations	30
Laminates Selection	31
Size 1000 1/2" Stack	32
Size 1000 3/4" Stack	33
Size 2000 3/4" Stack	34
Size 2000 1" Stack	35
Size 3000 1" Stack	36

Resource Information

Technical Reference	42
Stock Products Listing	46
Index	47
Terms and Conditions	48

DORMEYER

Dormeyer® is America's leading commercial AC solenoid brand.

We provide electromechanical and electromagnetic solutions for appliance and commercial grade actuation applications. Our AC open frame and laminate product lines are designed for high-volume applications, and are tailored for high force, short stroke solutions.

The application of Dormeyer products is universal – from garage doors, ice and beverage dispensers to garbage disposals and washing machines.

We provide excellent customer service and delivery performance to support your high volume AC solenoid requirements.

We look forward to working with you.



ERMEC, S.L. BARCELONA
C/ Francesc Teixidó, 22
E-08918 Badalona
(Spain)

Tel.: (+34) 902 450 160
Fax: (+34) 902 433 088
info@ermec.com
www.ermec.com

ERMEC, S.L. MADRID
C/ Sagasta, 8, 1ª planta
E-28004 Madrid
(Spain)

PORTUGAL
portugal@ermec.com
BILBAO
bilbao@ermec.com



OVERVIEW

The Johnson Electric Group is one of the world's largest providers of motion actuators for automotive and industrial applications

Over the years, we have shipped billions of motors to more than thirty countries in over one hundred different motor applications. Johnson Electric has an annual production capacity of one billion motors.

to meet all of our commitments and to support our customers' success. Product reliability and assurance of supply are our commitment.

At the heart of Johnson Electric's success is our commitment to make our customers successful. Our customers include many of the world's leading industrial, consumer and automotive companies. We begin by understanding our customers' business needs, and the product application requirements of the end user of our customers' products. Then we design and deliver innovative motion solutions that help our customers to differentiate their products in the marketplace. Our goal is to be instrumental in the successful launch of our customers' products in their respective marketplaces.

Our Brand Promise

Johnson Electric is the most reliable partner

Johnson Electric is responsive and flexible; and has the financial stability and organizational integrity

Johnson Electric delivers competitive advantage

Johnson Electric delivers differentiation and innovation through its motion products – subsystems comprising of Stepper Motors, DC Motors, AC Motors, Piezo-electric Motors, Switches, Solenoids, Flexi Circuits, Motion Control, Precision Plastics and Precision Gears.

Our business growth hinges with leading "branded" goods producers to deliver differentiation and innovation through our motion products. The core platform for delivering these solutions is a highly developed production base and focused customer support teams throughout the world. This combines scale advantages in production and procurement with skilled and dedicated motion application experts.



ERMEC, S.L. BARCELONA
C/ Francesc Teixidó, 22
E-08918 Badalona
(Spain)

Tel.: (+34) 902 450 160
Fax: (+34) 902 433 088
info@ermec.com
www.ermec.com

ERMEC, S.L. MADRID
C/ Sagasta, 8, 1ª planta
E-28004 Madrid
(Spain)

PORTUGAL
portugal@ermec.com
BILBAO
bilbao@ermec.com



HOW WE ARE ORGANIZED

Johnson Electric Holdings Limited is the parent company of the Johnson Electric Group and has been listed on the Stock Exchange of Hong Kong since 1984. The Group structure consists of a number of operating divisions and business units focused on their particular customer application or product segment

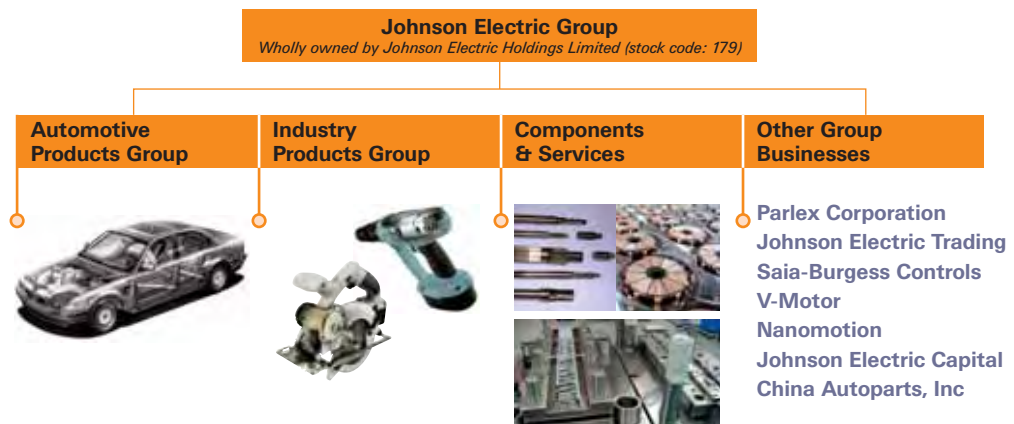

The Group's motion systems, motors and switches businesses are managed through two primary operating divisions: Automotive Products Group and Industry Products Group.

The Automotive Products Group, which consists of Johnson Electric's Automotive Motors Group and the Automotive Division of Saia-Burgess Electronics, is focused on providing customized motion solutions for major automotive application segments that include powertrain, body and chassis.

The Industry Products Group is comprised of business units that provide motion products and solutions for various commercial and industrial application sectors, including home appliances, power tools, business equipment, personal care products, medical equipment and healthcare, building automation and security, audio-visual and other industrial products.

Supporting these two operating divisions is the Group's Components & Services function which produces metal and plastic parts, tooling and production equipment for motor and motion related products. Johnson Electric is a highly vertically integrated business that manufactures an exceptionally wide range of components that form the basis for its final assembled end products. We make magnets, bearings, shafts, housings, laminations, commutators and die cast parts. We also build tools, assembly fixtures, plastic molds as well as armature winding and other production machines.

In addition to motion systems and motors, the Group also consists of a number of complementary manufacturing businesses and other subsidiary companies. These include an innovative provider of flexible printed circuits and interconnect solutions; a successful niche player in the programmable controls industry; and a rapidly growing specialty metals and trading services company.

Dormeyer® Solenoid Solutions

Dormeyer® Solenoids are found in many commercial applications from garage doors to vending machines. Let our experience work for you.

Below are some of the primary functions which are ideally suited for Dormeyer® AC solenoids.

We can help you determine the best solenoid to meet your application design requirements.

Common Applications

- Vending machines
- Brakes
- Copiers
- Door locks
- Pumps
- Coin changers
- Film processors
- Drug management systems

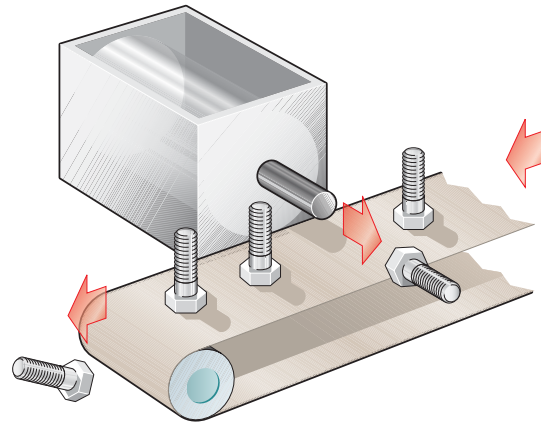

Kick

Solenoid snap-acting response and electric operation are beneficial for part rejection processes in which electronic interfacing with a photosensor or some other sensor is required.

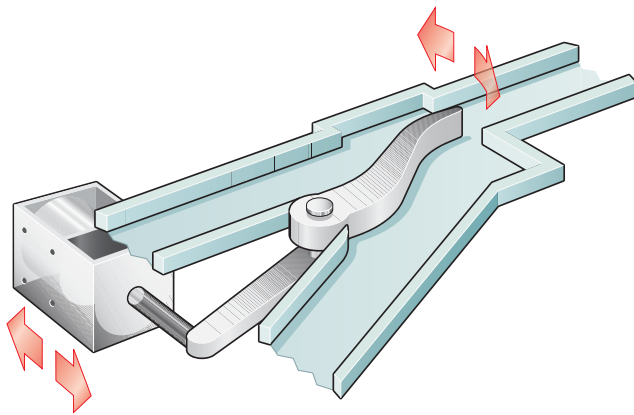

Divert

Gate diverters, depending on the application, can be used continuously or very infrequently.

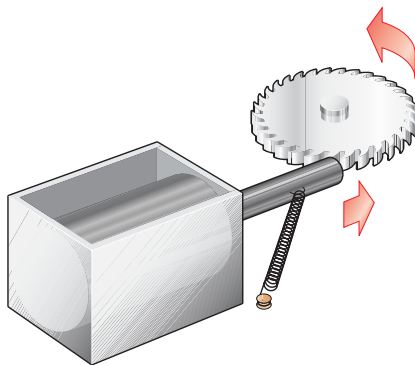
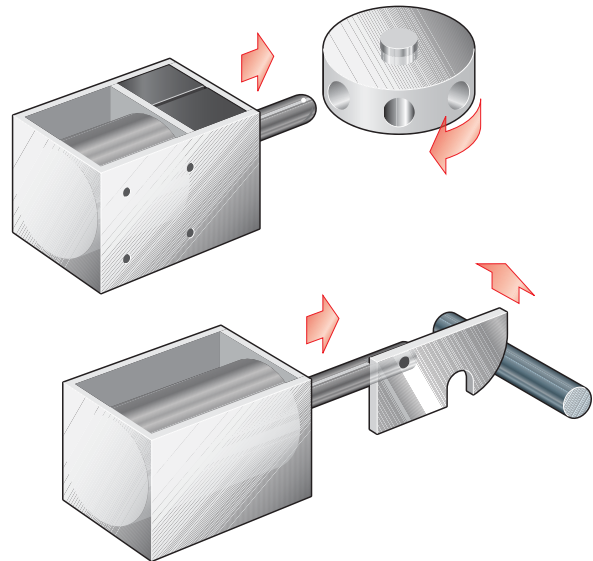

Position

Positioning applications can range from a simple ratcheting device to precise variable positioning.

Lock/Latch

Low cost, compact size, reliability, and long life are all reasons for the growing demand for Dormeyer open frame solenoids and laminates in a wide variety of locking applications.

ERMEC ERMEC, S.L. BARCELONA
C/ Francesc Teixidó, 22
E-08918 Badalona

Tel.: (+34) 902 450 160
Fax: (+34) 902 433 088
info@ermec.com
www.ermec.com

ERMEC, S.L. MADRID
C/ Sagasta, 8, 1ª planta
E-28004 Madrid
(Spain)

PORTUGAL
portugal@ermec.com
BILBAO
bilbao@ermec.com



Dormeyer® Application Examples

Solenoids and Laminates for Appliances and Commercial Products

Dormeyer® products are used for on/off functions on numerous residential and commercial applications requiring maximum cost/performance efficiency

Residential Appliances

- Through the door refrigerator ice and water dispensers
- Door locks on self-cleaning ovens
- Gas valve control on gas ranges and ovens
- Drain control valves on residential washing machines
- Brake solenoids on residential washing machines
- Vacuum packaging

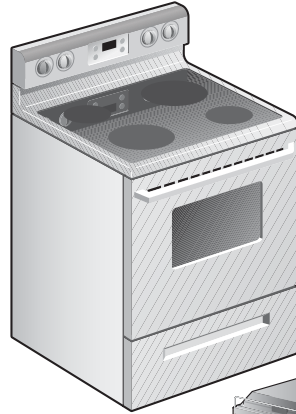

Commercial Appliances

- Hydraulic systems
- Chemical control systems
- Dispensing valves
- Beverage dispensing valves
- Product dispensers on vending machines
- Coin changers on vending machines
- Actuating devices on commercial baking and food processing or packaging equipment
- Wrapping material cutters for food packaging
- Gas valve control on gas fired boilers and furnaces
- Industrial overhead door brake mechanisms

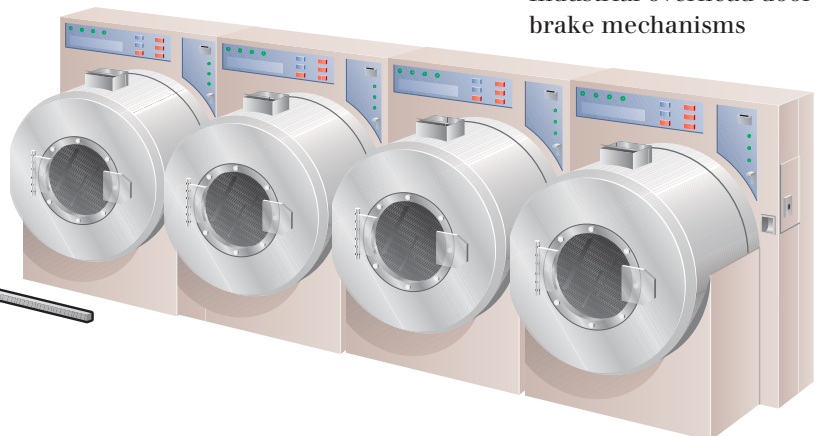
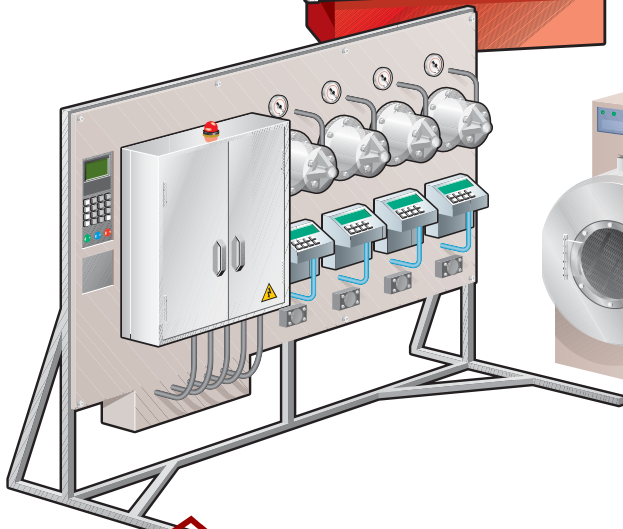
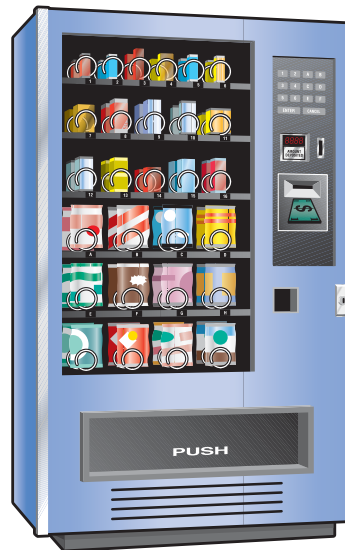

Open Frame Solenoids

Box Frame Solenoids

- Characteristics
- Pull-in operation
 - Stronger frame
 - Higher efficiency
 - On/off operation



Model	B4HD	B11	B20	B21	B22
Dimensions H x W x L (in)	1.63 x 1.44 x 2.18	1.18 x 0.94 x 1.86	0.94 x 0.81 x 1.14	1.31 x 1.31 x 1.20	1.47 x 1.31 x 1.61
Duty Cycle	Continuous or intermittent	Continuous or intermittent	Continuous or intermittent	Continuous or intermittent	Continuous or intermittent
Stroke (in)	Up to 1.00	Up to 1.00	Up to 0.5	Up to 0.5	Up to 1.00
Force (lb)	Up to 18	Up to 6	Up to 3	Up to 6	Up to 12
Life	50,000 to 100,000 cycles	50,000 to 100,000 cycles	50,000 to 100,000 cycles	50,000 to 100,000 cycles	50,000 to 100,000 cycles
Cycles/Second* (Hz)	60	60	60	60	60
Supply (V)*	120 or 240	120 or 240	120 or 240	120 or 240	120 or 240
Housing	Box frame	Box frame	Box frame	Box frame	Box frame

C Frame Solenoids

- Characteristics
- Pull-in operation (push types available)
 - Most economical
 - On/off operation



Model	C8	C9	C15	C26	C33	C34
Dimensions H x W x L (in)	0.81 x 0.75 x 1.13	1.25 x 1.38 x 1.06	1.00 x 1.06 x 1.14	0.90 x 0.85 x 1.73	1.14 x 1.31 x 1.36	1.44 x 1.31 x 1.66
Duty Cycle	Continuous or intermittent	Continuous or intermittent	Continuous or intermittent	Continuous or intermittent	Continuous or intermittent	Continuous or intermittent
Stroke (in)	Up to 0.5	Up to 0.5	Up to 0.5	Up to 0.75	Up to 0.05	Up to 1.00
Force (lb)	Up to 3.5	Up to 6.6	Up to 5	Up to 5	Up to 6	Up to 10
Life	50,000 to 100,000 cycles	50,000 to 100,000 cycles	50,000 to 100,000 cycles	50,000 to 100,000 cycles	50,000 to 100,000 cycles	50,000 to 100,000 cycles
Cycles/Second* (Hz)	60	60	60	60	60	60
Supply (V)*	120 or 240	120 or 240	120 or 240	120 or 240	120 or 240	120 or 240
Housing	C frame	C frame	C frame	C frame	C frame	C frame

All catalog products manufactured after
April 1, 2006 are RoHS Compliant

* 230 VAC, 50 Hz models available – please contact us.

Laminate Solenoids

Laminates

- Characteristics
- Short stroke, very high force
 - Low cost, high volume products
 - Custom design work is our strength
 - 120 or 240 VAC



Model	1000	1000	2000	2000	3000
Dimensions H x W x L (in)	1.44 x 1.19 x 1.61	1.43 x 1.44 x 1.61	2.06 x 1.81 x 2.50	2.06 x 2.06 x 2.50	2.94 x 2.38 x 2.97
Duty Cycle	Continuous or intermittent	Continuous or intermittent	Continuous or intermittent	Continuous or intermittent	Continuous or intermittent
Max. Stroke (in)	0.75	0.75	Up to 0.5	1.00	1.25
Nom. Stroke (in)	0.375	0.375	0.50	0.50	0.50
Force (lb)	Up to 8	Up to 18	Up to 16	Up to 32	Up to 36
Cycles/Second (Hz)	60	60	60	60	60
Supply (V)	120/240	120/240	120/240	120/240	120/240
Stack Size (in)	1/2	3/4	3/4	1	1

All catalog products manufactured after
April 1, 2006 are RoHS Compliant

Dormeyer® Value-Added Solenoid Assemblies

If your application requires more than a standard product solution, please consider us early in your design effort. Our application engineering staff will be happy to discuss your requirements.

The examples below and on the next page are just a few samples that demonstrate our design and value-added assembly capabilities.

We look forward to the opportunity to work with you.



Special open frame solenoid with built-in "latch on/latch off" function and mounting plate with brackets for mounting miniature switches



"C" Frame solenoid with integral mounting bracket, overmolded coil, special armature attachment, plunger stop and locking feature

"C" Frame solenoid with special plunger end for optical sensing, and built-in full wave bridge rectifier for use with AC voltage



Every Dormeyer Open Frame and Laminate product can be modified in any number of ways to match your EXACT application requirements.



Looking for a Specialized Solenoid Solution?

Look no further.

We offer the industry's most comprehensive combination of technology, engineering and manufacturing to satisfy all your actuation design needs. From stand-alone solenoid products to complete value-added solutions; we can do it all for you. The images shown are just a few examples of our design and value-added sub-assembly capabilities.

We look forward to the opportunity to work with you.

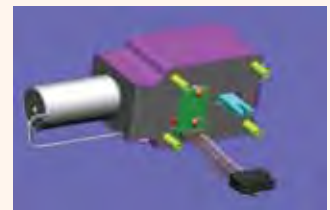
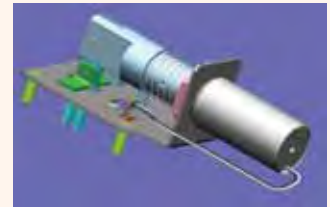
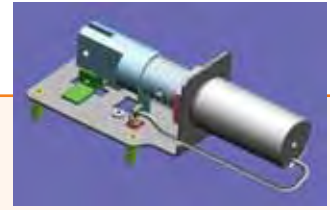
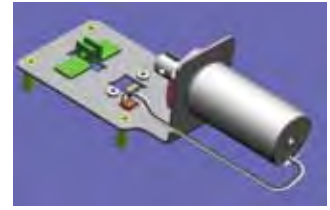
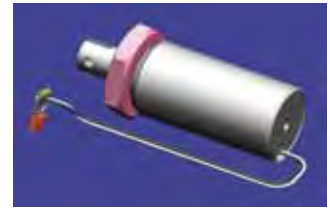

Dormeyer® Value-Added Sub-Assemblies

We specialize in the production of custom sub-assemblies, not just solenoids. The following example is typical of what we do to add value for our customers every day:

Customer Request:

Our customer had a demanding application for a complete solenoid sub-system including drive electronics, surge suppression, and a feedback sensor.

Dormeyer® Solution:

We designed a complete system solution for the customer in a matter of weeks from concept to completion.

Completed units are tested, packaged, and shipped to the customer ready for easy installation.

Materials for this assembly include:

Dormeyer solenoid PLUS . . .



- Bracket • Adaptor • Spring • Hex Nut • Optical Sensor
- Connector and Cable • PCB • PC Cable • Actuator Arm
- Stand Offs • Trans. Voltage Suppression • Housing



Dormeyer® Open Frame Solenoids



- Low cost, high volume products
- Strokes to 1.25 inches
- Custom design work is our strength

Applications

- Appliances
- Printers
- Coin dispensers
- Security door locks
- Storage/retrieval systems
- PC board insertion equipment
- Vending

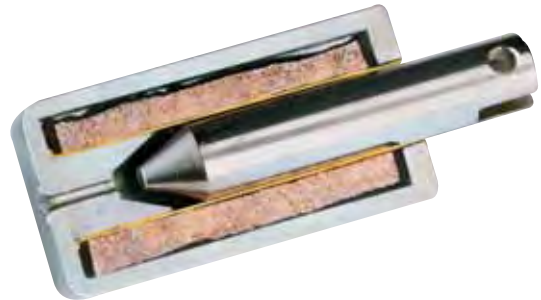

All catalog products manufactured after April 1, 2006 are RoHS Compliant

The open frame solenoid is the simplest solenoid device consisting of an open iron frame, an overmolded or taped coil, and a movable plunger in the center of the coil. Open frame solenoids are the most economical of all the solenoid types.

Applications for Dormeyer® AC open frame devices are numerous. Open frame solenoids are well suited for applications which require locking and latching functions.

Applications for Dormeyer AC open frame solenoids include residential and commercial door locks, credit card key “smart” locks, self-cleaning oven locks, front-loading washing machine and dishwasher locks, computer cartridge locks, and many more.

Principle of Operation

The open frame solenoid consists of an open iron frame, a coil, and a movable plunger in the center of the coil. When energized, the plunger is pulled into the stator which consists of the frame and coil.

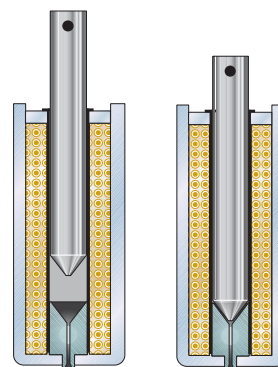

De-energized

Energized

Selection Overview

Use the selection charts on page 12 to determine which model offers the desired performance and mechanical specifications.

Refer to the individual frame size specification pages for complete performance and mechanical data.

Even with our many standard solenoid designs, our customers often require a product with unique features or performance capabilities. If you don't find what you're looking for in the catalog, please give us a call and talk to one of our application engineers.

Dormeyer® Open Frame Solenoids

Design Considerations

Construction

Open frame solenoids are designed with two frame styles, the C Frame style, in which the coil is enclosed on one side, and the Box Frame style in which the coil is enclosed on two sides. The Box Frame style provides slightly higher force output and is more rugged in design.

Tapped mounting holes are used for easy installation and interchangeability.

Most models have slotted and cross drilled plungers for easy load attachment.

The plunger is plated for corrosion resistance, and provides a low coefficient of friction and long life.

Over molded coils are available in both Box Frame and C Frame solenoids and offer excellent protection from moisture and humidity. Some solenoids are UL recognized. Most have UL recognized coil insulation systems.

Life

When selecting an open frame solenoid, as with any other solenoid style, it is important to consider the effects of heat, since an increase in coil temperature reduces the work output and the life of the unit. Standard life is 50,000 to 100,000 operations. Consult the factory for longer life of 500,000 or more cycles, and other special requirements.

Duty Cycle

Duty cycle is determined by solenoid ON time/(ON + OFF time).

For example: a solenoid is actuated for 30 seconds, then off for 90 seconds.
 $30 \text{ sec ON} / (30 \text{ Sec ON} + 90 \text{ sec OFF}) = 30/120 = 1/4$ or 25% duty cycle.

Performance Curves

The Force/Stroke performance curves in this section serve as guides to determine the solenoid size needed to produce a desired force at a given stroke, duty cycle, and power source. All Force/Stroke curves are performed under standard test conditions: ambient temperature of 20°C. A design safety factor of 1.5 to 1.5 is recommended. For example, when a 4.5 lb pull force is required, select a model with a safety factor of 1.5 to 1.5 times (5.8 to 6.7 lb).

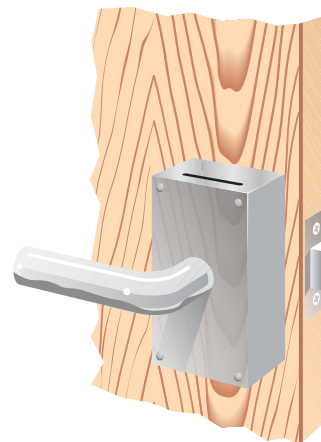
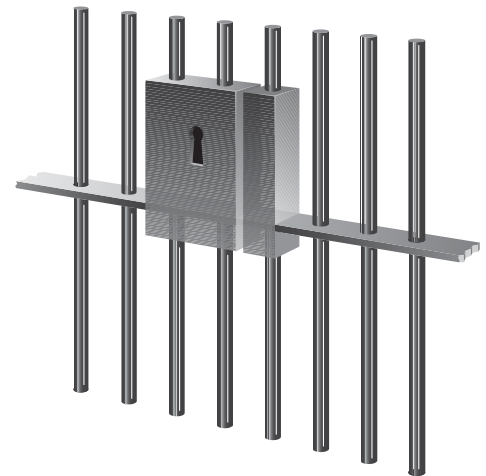

Dormeyer® AC Open Frame Solenoid Selection

AC actuated open frame solenoids are available in box frame and C frame design styles in a variety of models and sizes.

Models are available for continuous use and intermittent duty.

For higher force applications, consider an laminate solenoid.



Box Frame

This solenoid has a 4-sided closed box frame and solid plunger and is, therefore, more electrically efficient than the C Frame solenoid. The closed, box frame also provides improved mechanical strength.



C Frame

C Frame solenoids consist of a formed C-shaped steel frame and solid plunger. Therefore, these solenoids are less efficient and less costly than their Box Frame counterparts.

All catalog products manufactured after April 1, 2006 are RoHS Compliant

Size	Frame Type	Coil Type ⁽¹⁾	Height (inches)	Width (inches)	Length (inches)	Max. Stroke (inches)	Nominal Stroke (inches)	Typical Force (lbs)		Page
								Nominal Stroke and 100% Rated Voltage @ 100% Duty	25% Duty	
B4HD	Box	OM	1.63	1.45	2.18	1.00	0.50	1.3	5.0	13
B11	Box	OM	1.18	0.94	1.86	1.00	0.40	0.7	1.3	14
B20	Box	T	0.94	0.81	1.14	0.50	0.25	0.2	0.5	15
B21	Box	T	1.31	1.31	1.20	0.63	0.25	0.9	1.6	16
B22	Box	OM	1.47	1.31	1.61	1.00	0.40	1.2	2.6	17
C8	C	OM	0.81	0.75	1.13	0.50	0.25	0.2	0.4	18
C9	C	T	1.25	1.38	1.06	0.50	0.25	1.3	2.5	19
C15	C	T	1.00	1.06	1.14	0.50	0.25	0.6	0.8	20
C26	C	OM	0.90	0.85	1.73	1.00	0.50	0.3	0.7	21
C33	C	OM	1.14	1.31	1.36	0.50	0.25	0.6	1.2	22
C34	C	OM	1.44	1.31	1.66	1.00	0.50	1.1	2.1	23

⁽¹⁾ OM = Overmolded; T = Taped

All specifications subject to change without notice.

Dormeyer® Box Frame Size B4HD — AC Operation

Specifications

Continuous Duty Cycle	100% at 20°C ambient temperature
Intermittent Duty Cycle	20% on time, 80% off time. On time not to exceed 3 min. at 20°C ambient temperature
Direction of Load Movement	Pull
Coil Insulation	Class "A": 105°C max. temperature standard. Other temperature classes are available
Coil Termination	3/16" QC
Plunger Weight	2.2 oz. (62.4 g)
Total Weight	12.5 oz. (354 g)
Dimensions	See page 24

AC Continuous Duty

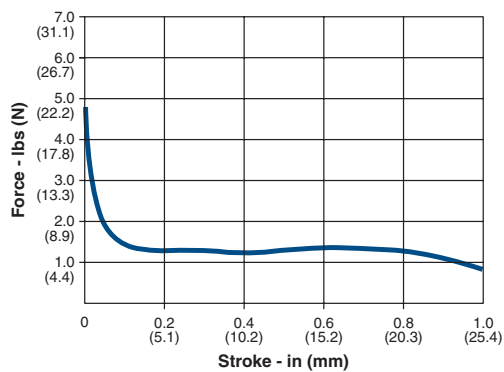

AC Intermittent Duty

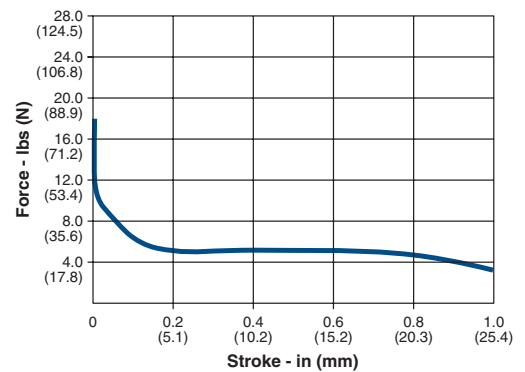

Duty Cycle	Continuous – 31 VA		Intermittent – 145 VA	
Model	B4HD-1-M-36	B4HD-2-M-36	B4HD-501-M-36	B4HD-502-M-36
Volts — 60Hz (50 Hz avail.)	120	240	120	240
Coil Resistance ± 10% (Ohms at 25°C)	73	320	19.3	78
Amps Seated ± 10%	0.155	0.075	1.146	0.580
Amps at 1/8" ± 10%	0.340	0.187	1.876	0.874
Amps at 1/4" ± 10%	0.460	0.269	2.370	1.147
Amps at 3/8" ± 10%	0.575	0.309	2.804	1.348
Amps at 1/2" ± 10%	0.690	0.381	3.221	1.552
Amps at 5/8" ± 10%	0.805	0.412	3.566	1.729
Amps at 3/4" ± 10%	0.910	0.467	3.875	1.928
Amps at 7/8" ± 10%	1.000	0.517	4.085	2.033
Amps at 1" ± 10%	1.050	0.558	4.214	2.119

NOTES:

- All data is typical.
- Force testing is done with the solenoid in the horizontal position.
- All data reflects operation with no heatsink.
- Other coil terminations available.
- 230V/50 Hz models are also available. Please contact us for ordering information.
- All specifications subject to change without notice.

How to Order

Select the part number from the table provided. (For example, to order a continuous duty cycle unit rated at 120 VAC, specify B4HD-1-M-36.

Please see www.dormeyer-solenoids.com (click on Stock Products tab) for our list of stock products available through our distributors.

Dormeyer® Box Frame Size B11 — AC Operation

Specifications

Continuous Duty Cycle	100% at 20°C ambient temperature
Intermittent Duty Cycle	20% on time, 80% off time. On time not to exceed 3 min. at 20°C ambient temperature
Direction of Load Movement	Pull
Coil Insulation	Class "A": 105°C max. temperature standard. Other temperature classes are available
Coil Termination	3/16" QC
Plunger Weight	0.6 oz. (17 g)
Total Weight	5.1 oz. (144 g)
Dimensions	See page 24

AC Continuous Duty

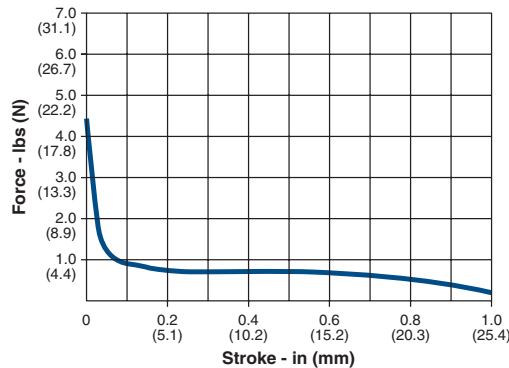

AC Intermittent Duty

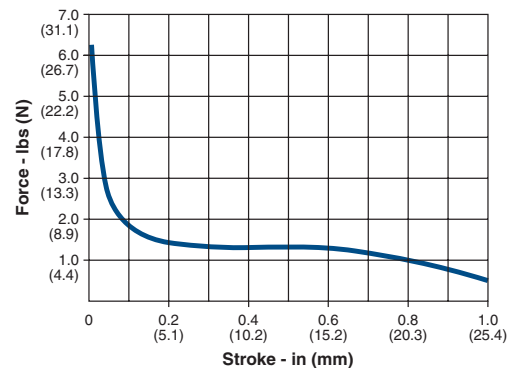

Duty Cycle	Continuous – 12 VA		Intermittent – 40 VA	
Model	B11-1-M-36	B11-2-M-36	B11-501-M-36	B11-502-M-36
Volts — 60Hz (50 Hz avail.)	120	240	120	240
Coil Resistance ± 10% (Ohms at 25°C)	192	796	79.2	378
Amps Seated ± 10%	0.118	0.067	0.395	0.212
Amps at 1/8" ± 10%	0.239	0.129	0.647	0.308
Amps at 1/4" ± 10%	0.306	0.161	0.775	0.367
Amps at 3/8" ± 10%	0.358	0.182	0.877	0.415
Amps at 1/2" ± 10%	0.409	0.205	0.975	0.458
Amps at 5/8" ± 10%	0.457	0.235	1.063	0.485
Amps at 3/4" ± 10%	0.485	0.249	1.146	0.521

NOTES:

- All data is typical.
- Force testing is done with the solenoid in the horizontal position.
- All data reflects operation with no heatsink.
- Other coil terminations available.
- 230V/50 Hz models are also available. Please contact us for ordering information.
- All specifications subject to change without notice.

How to Order

Select the part number from the table provided. (For example, to order a continuous duty cycle unit rated at 120 VAC, specify B11-1-M-36.

Please see www.dormeyer-solenoids.com (click on Stock Products tab) for our list of stock products available through our distributors.

Dormeyer® Box Frame Size B20 — AC Operation

Specifications

Continuous Duty Cycle	100% at 20°C ambient temperature
Intermittent Duty Cycle	20% on time, 80% off time. On time not to exceed 3 min. at 20°C ambient temperature
Direction of Load Movement	Pull
Coil Insulation	Class "A": 105°C max. temperature standard. Other temperature classes are available
Coil Termination	Lead wires
Plunger Weight	0.58 oz. (16.4 g)
Total Weight	2.17 oz. (61.6 g)
Dimensions	See page 25

AC Continuous Duty

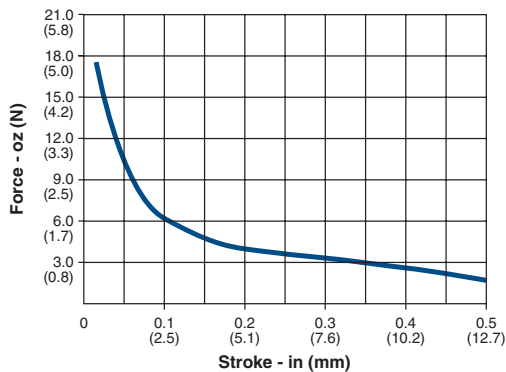

AC Intermittent Duty

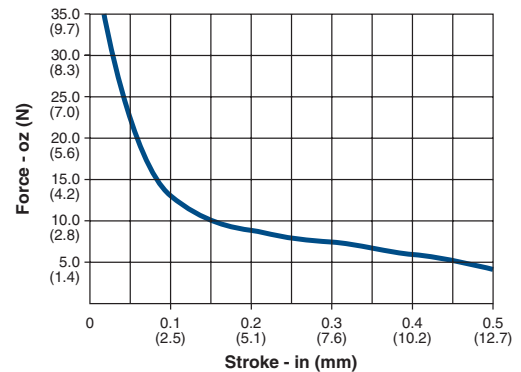

Duty Cycle	Continuous – 8 VA		Intermittent – 18 VA	
Model	B20-1-A-3	B20-2-A-3	B20-501-A-3	B20-502-A-3
Volts — 60Hz (50 Hz avail.)	120	240	120	240
Coil Resistance ± 10% (Ohms at 25°C)	580	3000	338	1410
Amps Seated ± 10%	0.074	0.032	0.149	0.075
Amps at 1/8" ± 10%	0.139	0.060	0.157	0.129
Amps at 1/4" ± 10%	0.165	0.670	0.298	0.149
Amps at 3/8" ± 10%	0.181	0.720	0.320	0.160
Amps at 1/2" ± 10%	0.188	0.740	0.329	0.164

NOTES:

- All data is typical.
- Force testing is done with the solenoid in the horizontal position.
- All data reflects operation with no heatsink.
- Other coil terminations available.
- 250V/50 Hz models are also available. Please contact us for ordering information.
- All specifications subject to change without notice.

How to Order

Select the part number from the table provided. (For example, to order a continuous duty cycle unit rated at 120 VAC, specify B20-1-A-3.

Please see www.dormeyer-solenoids.com (click on Stock Products tab) for our list of stock products available through our distributors.

Dormeyer® Box Frame Size B21 — AC Operation

Specifications

Continuous Duty Cycle 100% at 20°C ambient temperature
 Intermittent Duty Cycle 20% on time, 80% off time. On time not to exceed 3 min. at 20°C ambient temperature

Direction of Load Movement Pull
 Coil Insulation Class "A": 105°C max. temperature standard. Other temperature classes are available
 Coil Termination Lead wires
 Plunger Weight 0.87 oz. (24.0 g)
 Total Weight 4.67 oz. (132.4 g)
 Dimensions See page 25

All catalog products manufactured after April 1, 2006 are RoHS Compliant

AC Continuous Duty

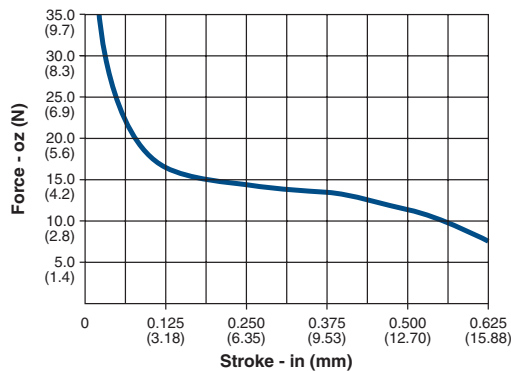

AC Intermittent Duty

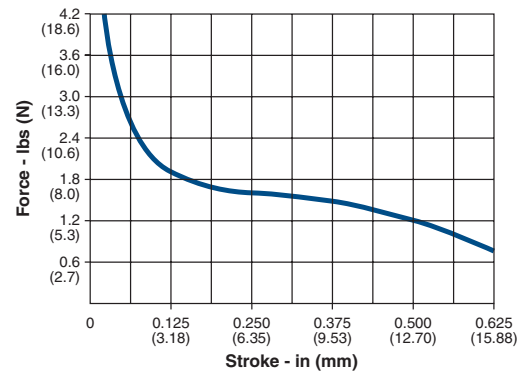

Duty Cycle	Continuous – 12 VA		Intermittent – 28 VA	
Model	B21-1-A-3	B21-2-A-3	B21-501-A-3	B21-502-A-3
Volts — 60Hz (50 Hz avail.)	120	240	120	240
Coil Resistance ± 10% (Ohms at 25°C)	234	950	124	495
Amps Seated ± 10%	0.099	0.050	0.230	0.121
Amps at 1/8" ± 10%	0.244	0.122	0.493	0.254
Amps at 1/4" ± 10%	0.324	0.161	0.639	0.327
Amps at 3/8" ± 10%	0.387	0.294	0.746	0.380
Amps at 1/2" ± 10%	0.432	0.216	0.814	0.412
Amps at 3/4" ± 10%	0.457	0.228	0.844	0.425

NOTES:

- All data is typical.
- Force testing is done with the solenoid in the horizontal position.
- All data reflects operation with no heatsink.
- Other coil terminations available.
- 230V/50 Hz models are also available. Please contact us for ordering information.
- All specifications subject to change without notice.

How to Order

Select the part number from the table provided. (For example, to order a continuous duty cycle unit rated at 120 VAC, specify B21-1-A-5.)

Please see www.dormeyer-solenoids.com (click on Stock Products tab) for our list of stock products available through our distributors.

All specifications subject to change without notice.

Dormeyer® Box Frame Size B22 — AC Operation

Specifications

Continuous Duty Cycle	100% at 20°C ambient temperature
Intermittent Duty Cycle	20% on time, 80% off time. On time not to exceed 3 min. at 20°C ambient temperature
Direction of Load Movement	Pull
Coil Insulation	Class "A": 105°C max. temperature standard. Other temperature classes are available
Coil Termination	3/16" QC
Plunger Weight	1.5 oz. (42.5 g)
Total Weight	8.0 oz. (227 g)
Dimensions	See page 26

All catalog products manufactured after April 1, 2006 are RoHS Compliant

AC Continuous Duty

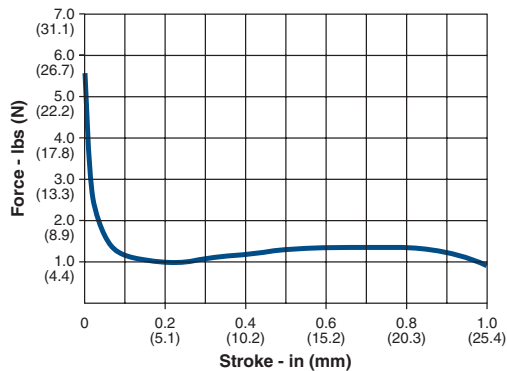

AC Intermittent Duty

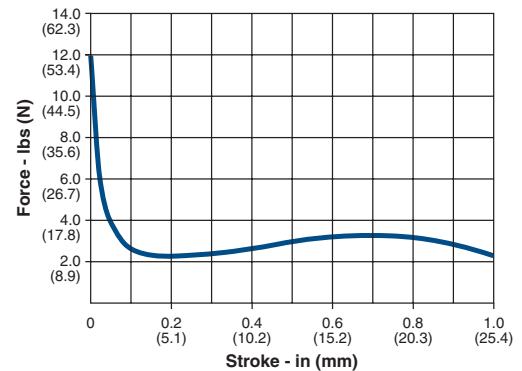

Duty Cycle	Continuous – 12 VA		Intermittent – 40 VA	
Model	B22-1-M-36	B22-2-M-36	B22-501-M-36	B22-502-M-36
Volts — 60Hz (50 Hz avail.)	120	240	120	240
Coil Resistance ± 10% (Ohms at 25°C)	107	433	40.5	163
Amps Seated ± 10%	0.162	0.090	0.548	0.357
Amps at 1/8" ± 10%	0.322	0.220	0.920	0.528
Amps at 1/4" ± 10%	0.417	0.247	1.135	0.625
Amps at 3/8" ± 10%	0.492	0.308	1.365	0.735
Amps at 1/2" ± 10%	0.603	0.368	1.593	0.872
Amps at 5/8" ± 10%	0.697	0.403	1.835	1.007
Amps at 3/4" ± 10%	0.793	0.438	2.077	1.128
Amps at 7/8" ± 10%	0.870	0.482	2.267	1.227
Amps at 1" ± 10%	0.925	0.523	2.405	1.283

NOTES:

- All data is typical.
- Force testing is done with the solenoid in the horizontal position.
- All data reflects operation with no heatsink.
- Other coil terminations available.
- 230V/50 Hz models are also available. Please contact us for ordering information.
- All specifications subject to change without notice.

How to Order

Select the part number from the table provided. (For example, to order a continuous duty cycle unit rated at 120 VAC, specify B22-1-M-36.

Please see www.dormeyer-solenoids.com (click on Stock Products tab) for our list of stock products available through our distributors.

All specifications subject to change without notice.

Dormeyer® C Frame Size C8 — AC Operation

Specifications

Continuous Duty Cycle 100% at 20°C ambient temperature
 Intermittent Duty Cycle 20% on time, 80% off time. On time not to exceed 3 min. at 20°C ambient temperature

Direction of Load Movement Pull
 Coil Insulation Class "A": 105°C max. temperature standard. Other temperature classes are available
 Coil Termination 3/16" QC
 Plunger Weight 0.4 oz. (11.3 g)
 Total Weight 1.7 oz. (48.2 g)
 Dimensions See page 27

All catalog products manufactured after April 1, 2006 are RoHS Compliant

AC Continuous Duty

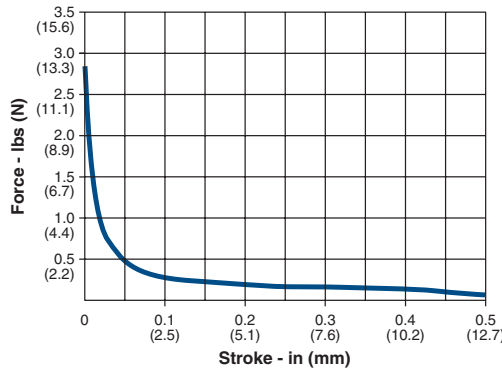

AC Intermittent Duty

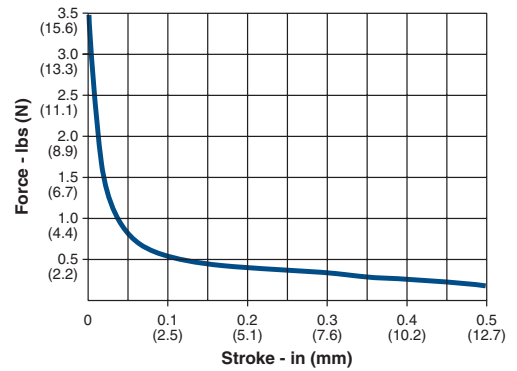

Duty Cycle	Continuous – 6.5 VA		Intermittent – 19 VA	
Model	C8-19-M-36	C8-20-M-36	C8-519-M-36	C8-520-M-36
Volts — 60Hz (50 Hz avail.)	120	240	120	240
Coil Resistance ± 10% (Ohms at 25°C)	840	3739	500	2010
Amps Seated ± 10%	0.0512	0.029	0.112	0.056
Amps at 1/8" ± 10%	0.102	0.502	0.122	0.089
Amps at 1/4" ± 10%	0.117	0.572	0.135	0.101
Amps at 3/8" ± 10%	0.126	0.613	0.143	0.109
Amps at 1/2" ± 10%	0.130	0.637	0.146	0.112

NOTES:

1. All data is typical.
2. Force testing is done with the solenoid in the horizontal position.
3. All data reflects operation with no heatsink.
4. Other coil terminations available.
5. 230V/50 Hz models are also available. Please contact us for ordering information.
6. All specifications subject to change without notice.

How to Order

Select the part number from the table provided. (For example, to order a continuous duty cycle unit rated at 120 VAC, specify C8-19-M-36.

Please see www.dormeyer-solenoids.com (click on Stock Products tab) for our list of stock products available through our distributors.

All specifications subject to change without notice.

Dormeyer® C Frame Size C9 — AC Operation

Specifications

Continuous Duty Cycle	100% at 20°C ambient temperature
Intermittent Duty Cycle	20% on time, 80% off time. On time not to exceed 3 min. at 20°C ambient temperature
Direction of Load Movement	Pull
Coil Insulation	Class "A": 105°C max. temperature standard. Other temperature classes are available
Coil Termination	Leadwires
Plunger Weight	0.9 oz. (25.2 g)
Total Weight	4.7 oz. (133.2 g)
Dimensions	See page 27

All catalog products manufactured after April 1, 2006 are RoHS Compliant

AC Continuous Duty

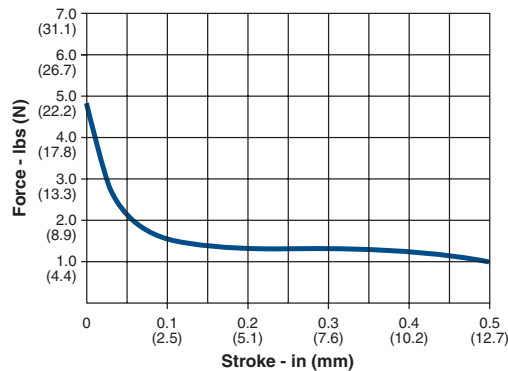

AC Intermittent Duty

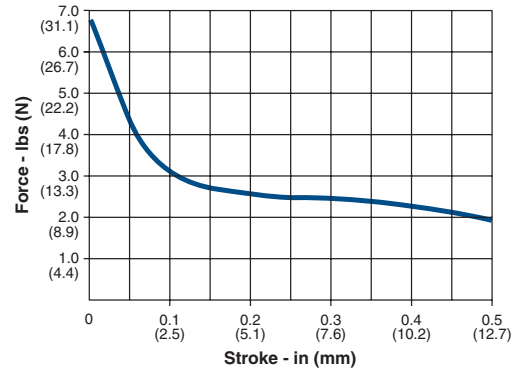

Duty Cycle	Continuous – 13 VA		Intermittent – 50 VA	
Model	C9-19-A-3	C9-20-A-3	C9-519-A-3	C9-520-A-3
Volts — 60Hz (50Hz avail.)	120	240	120	240
Coil Resistance ± 10% (Ohms at 25°C)	155	698	72.6	294
Amps Seated ± 10%	0.176	0.074	0.472	0.242
Amps at 1/8" ± 10%	0.338	0.151	0.783	0.401
Amps at 1/4" ± 10%	0.450	0.198	0.991	0.505
Amps at 3/8" ± 10%	0.541	0.238	1.165	0.597
Amps at 1/2" ± 10%	0.618	0.272	1.316	0.667

NOTES:

- All data is typical.
- Force testing is done with the solenoid in the horizontal position.
- All data reflects operation with no heatsink.
- Other coil terminations available.
- 230V/50 Hz models are also available. Please contact us for ordering information.
- All specifications subject to change without notice.

How to Order

Select the part number from the table provided. (For example, to order a continuous duty cycle unit rated at 120 VAC, specify C9-19-A-3.

Please see www.dormeyer-solenoids.com (click on Stock Products tab) for our list of stock products available through our distributors.

All specifications subject to change without notice.

Dormeyer® C Frame Size C15 — AC Operation

Specifications

Continuous Duty Cycle	At 20°C ambient temperature
Intermittent Duty Cycle	20% on time, 80% off time. On time not to exceed 3 min. at 20°C ambient temperature
Direction of Load Movement	Pull
Coil Insulation	Class "A": 105°C max. temperature standard. Other temperature classes are available
Coil Termination	Lead wires
Plunger Weight	0.5 oz. (14.2 g)
Total Weight	2.5 oz. (70.9 g)
Dimensions	See page 28

All catalog products manufactured after April 1, 2006 are RoHS Compliant

AC Continuous Duty

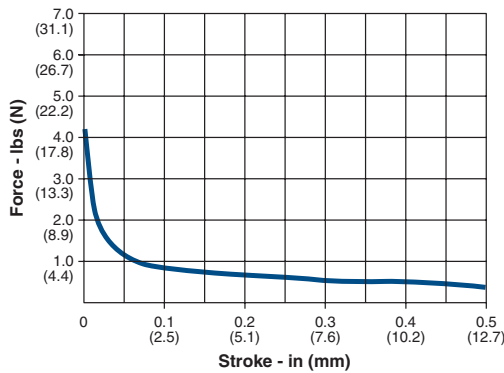

AC Intermittent Duty

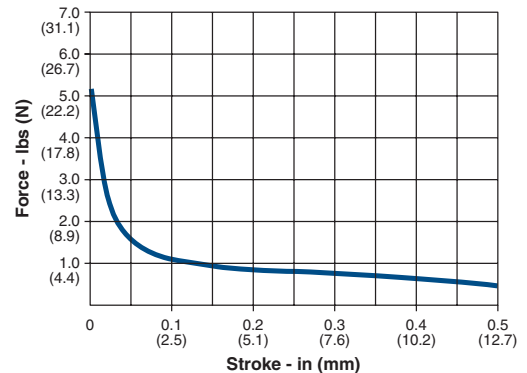

Duty Cycle	Continuous – 14 VA		Intermittent– 24 VA	
Model	C15-19-B-36	C15-20-B-36	C15-519-B-36	C15-520-B-36
Volts — 60Hz (50 Hz avail.)	120	240	120	240
Coil Resistance ± 10% (Ohms at 25°C)	350	1450	220	880
Amps Seated ± 10%	0.12	0.06	0.20	0.09
Amps at 1/8" ± 10%	0.23	0.12	0.35	0.16
Amps at 1/4" ± 10%	0.27	0.14	0.42	0.21
Amps at 3/8" ± 10%	0.31	0.16	0.48	0.24
Amps at 1/2" ± 10%	0.32	0.17	0.51	0.26

NOTES:

1. All data is typical.
2. Force testing is done with the solenoid in the horizontal position.
3. All data reflects operation with no heatsink.
4. Other coil terminations available.
5. 230V/50 Hz models are also available. Please contact us for ordering information.
6. All specifications subject to change without notice.

How to Order

Select the part number from the table provided. (For example, to order a continuous duty cycle unit rated at 120 VAC, specify C15-19-B-36.

Please see www.dormeyer-solenoids.com (click on Stock Products tab) for our list of stock products available through our distributors.

All specifications subject to change without notice.

Dormeyer® C Frame Size C26 — AC Operation

Specifications

Continuous Duty Cycle	100% at 20°C ambient temperature
Intermittent Duty Cycle	20% on time, 80% off time. On time not to exceed 3 min. at 20°C ambient temperature
Direction of Load Movement	Pull
Coil Insulation	Class "A": 105°C max. temperature standard. Other temperature classes are available
Coil Termination	3/16" QC
Plunger Weight	0.5 oz. (14.2 g)
Total Weight	3.0 oz. (85.1 g)
Dimensions	See page 28

All catalog products manufactured after April 1, 2006 are RoHS Compliant

AC Continuous Duty

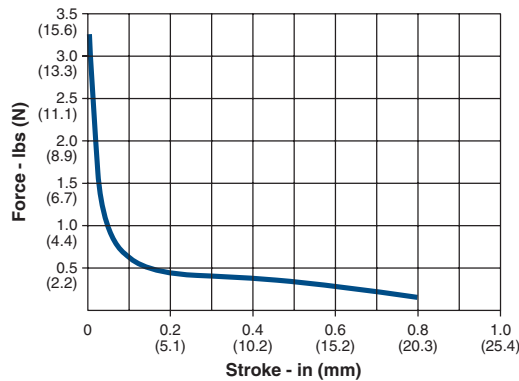

AC Intermittent Duty

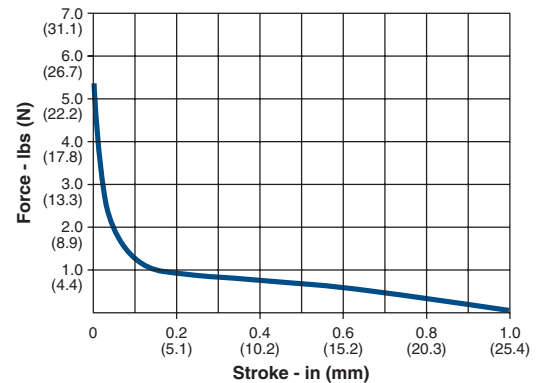

Duty Cycle	Continuous – 12 VA		Intermittent – 24 VA	
Model	C26-19-M-36	C26-20-M-36	C26-519-M-36	C26-520-M-36
Volts — 60Hz (50 Hz avail.)	120	240	120	240
Coil Resistance ± 10% (Ohms at 25°C)	364	1000	149	560
Amps Seated ± 10%	0.081	0.041	0.270	0.146
Amps at 1/8" ± 10%	0.167	0.083	0.405	0.200
Amps at 1/4" ± 10%	0.209	0.101	0.481	0.242
Amps at 3/8" ± 10%	0.242	0.117	0.543	0.275
Amps at 1/2" ± 10%	0.269	0.128	0.594	0.302
Amps at 5/8" ± 10%	0.290	0.138	0.634	0.322
Amps at 3/4" ± 10%	0.306	0.143	0.667	0.337
Amps at 7/8" ± 10%	0.320	0.146	0.687	0.348

NOTES:

- All data is typical.
- Force testing is done with the solenoid in the horizontal position.
- All data reflects operation with no heatsink.
- Other coil terminations available.
- 250V/50 Hz models are also available. Please contact us for ordering information.
- All specifications subject to change without notice.

How to Order

Select the part number from the table provided. (For example, to order a continuous duty cycle unit rated at 120 VAC, specify C26-19-M-36.

Please see www.dormeyer-solenoids.com (click on Stock Products tab) for our list of stock products available through our distributors.

All specifications subject to change without notice.



Dormeyer® C Frame Size C33 — AC Operation

Specifications

Continuous Duty Cycle	At 20°C ambient temperature
Intermittent Duty Cycle	20% on time, 80% off time. On time not to exceed 3 min. at 20°C ambient temperature
Direction of Load Movement	Pull
Coil Insulation	Class "A": 105°C max. temperature standard. Other temperature classes are available
Coil Termination	1/4" QC
Plunger Weight	0.5 oz. (14.2 g)
Total Weight	3.9 oz. (110.6 g)
Dimensions	See page 29

All catalog products manufactured after April 1, 2006 are RoHS Compliant

AC Continuous Duty

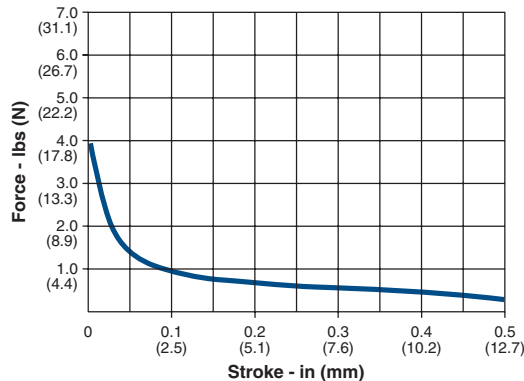

AC Intermittent Duty

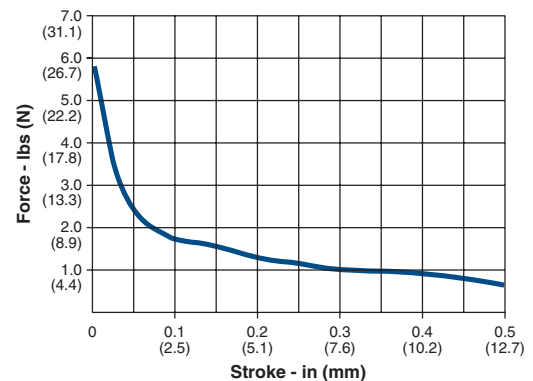

Duty Cycle	Continuous – 17 VA		Intermittent – 24 VA	
Model	C33-19-M-33	C33-20-M-33	C33-519-M-33	C33-520-M-33
Volts — 60Hz (50Hz avail.)	120	240	120	240
Coil Resistance ± 10% (Ohms at 25°C)	290	1156	166	652
Amps Seated ± 10%	0.14	0.07	0.26	0.10
Amps at 1/8" ± 10%	0.26	0.13	0.46	0.24
Amps at 1/4" ± 10%	0.32	0.16	0.52	0.28
Amps at 3/8" ± 10%	0.36	0.18	0.60	0.31
Amps at 1/2" ± 10%	0.38	0.19	0.65	0.33

NOTES:

- All data is typical.
- Force testing is done with the solenoid in the horizontal position.
- All data reflects operation with no heatsink.
- Other coil terminations available.
- 250V/50 Hz models are also available. Please contact us for ordering information.
- All specifications subject to change without notice.

How to Order

Select the part number from the table provided. (For example, to order a continuous duty cycle unit rated at 120 VAC, specify C33-19-M-33.

Please see www.dormeyer-solenoids.com (click on Stock Products tab) for our list of stock products available through our distributors.

All specifications subject to change without notice.

Dormeyer® C Frame Size C34 — AC Operation

Specifications

Continuous Duty Cycle	At 20°C ambient temperature
Intermittent Duty Cycle	20% on time, 80% off time. On time not to exceed 3 min. at 20°C ambient temperature
Direction of Load Movement	Pull
Coil Insulation	Class "A": 105°C max. temperature standard
Coil Termination	1/4" QC
Plunger Weight	1.4 oz. (39.7 g)
Total Weight	5.8 oz. (164.4 g)
Dimensions	See page 29

All catalog products manufactured after April 1, 2006 are RoHS Compliant

AC Continuous Duty

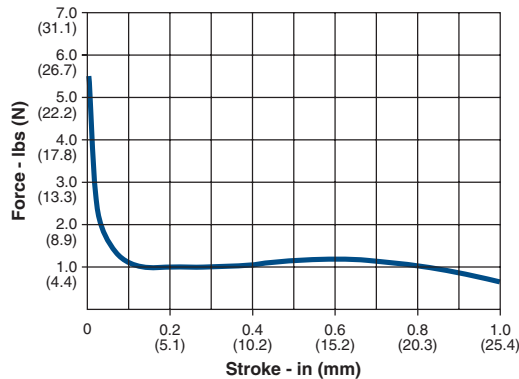

AC Intermittent Duty

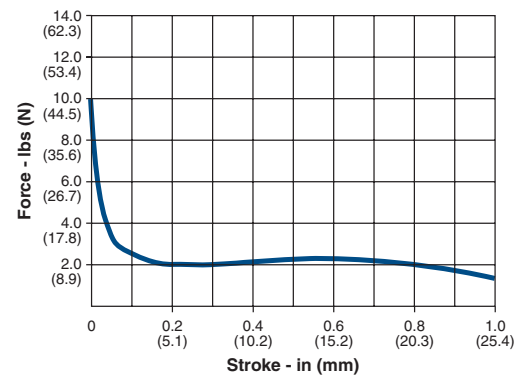

Duty Cycle	Continuous – 24 VA		Intermittent – 62 VA	
Model	C34-19-M-33	C34-20-M-33	C34-519-M-33	C34-520-M-33
Volts — 60Hz (50 Hz avail.)	120	240	120	240
Coil Resistance ± 10% (Ohms at 25°C)	128	524	55	219
Amps Seated ± 10%	0.20	0.10	0.54	0.26
Amps at 1/4" ± 10%	0.47	0.24	1.10	0.54
Amps at 1/2" ± 10%	0.63	0.32	1.50	0.72
Amps at 3/4" ± 10%	0.74	0.38	1.80	0.88
Amps at 1" ± 10%	0.86	0.42	1.90	0.96

NOTES:

- All data is typical.
- Force testing is done with the solenoid in the horizontal position.
- All data reflects operation with no heatsink.
- Other coil terminations available.
- 250V/50 Hz models are also available. Please contact us for ordering information.
- All specifications subject to change without notice.

How to Order

Select the part number from the table provided. (For example, to order a continuous duty cycle unit rated at 120 VAC, specify C34-19-M-33.

Please see www.dormeyer-solenoids.com (click on Stock Products tab) for our list of stock products available through our distributors.

All specifications subject to change without notice.

Dormeyer® Box Frame Dimensions

Inches (mm)

All solenoids are illustrated in energized state

NOTE: Many other metric and American standard threads are available.

B20

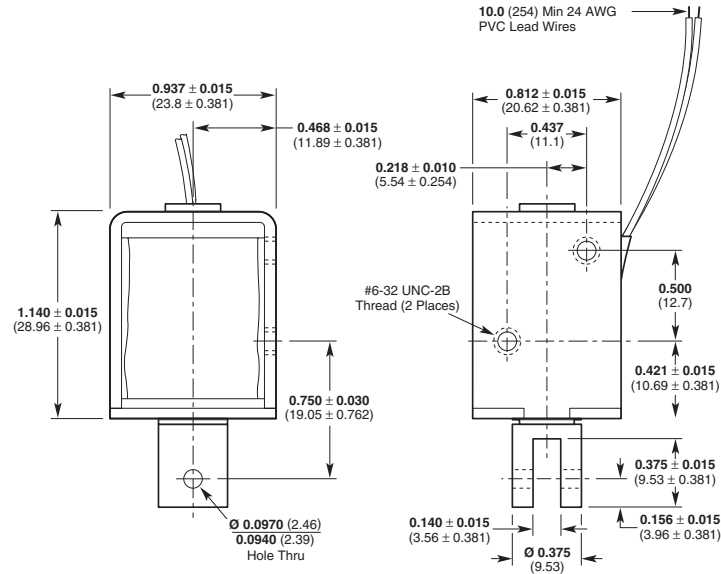

B21

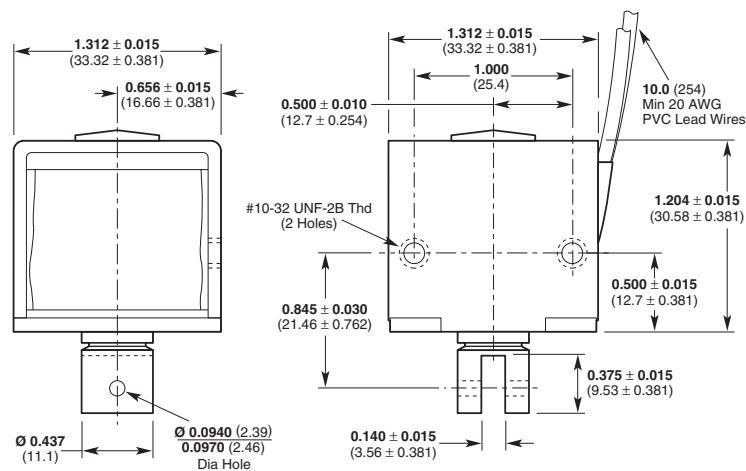

All specifications subject to change without notice.

Dormeyer® Box Frame Dimensions

Inches (mm)

All solenoids are illustrated in energized state

All catalog products manufactured after April 1, 2006 are RoHS Compliant

B22

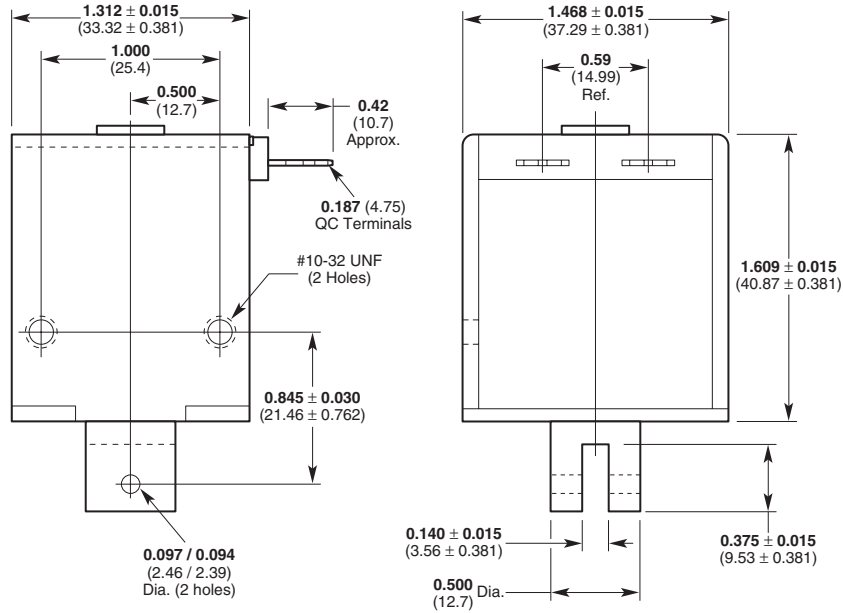

All specifications subject to change without notice.

Dormeyer® C Frame Dimensions

Inches (mm)

All solenoids are illustrated in energized state

NOTE: Many other metric and American standard threads are available.

C8

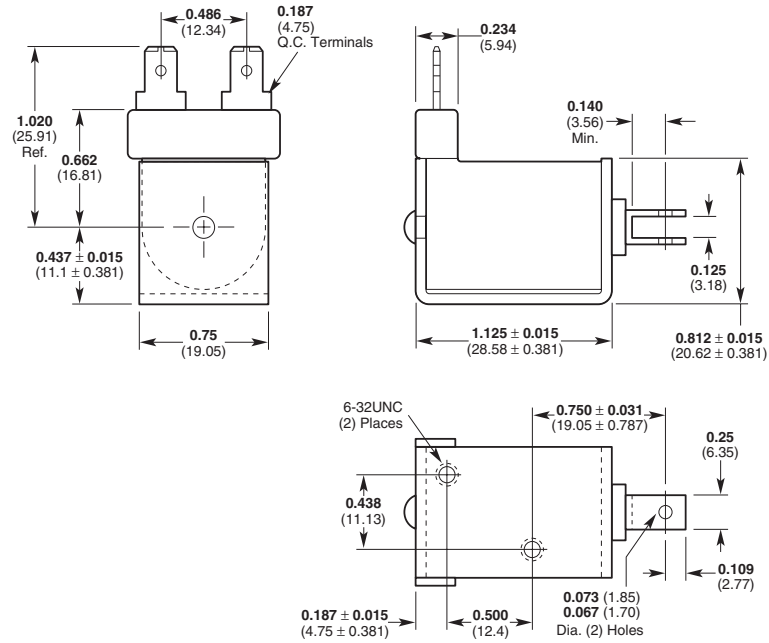

C9

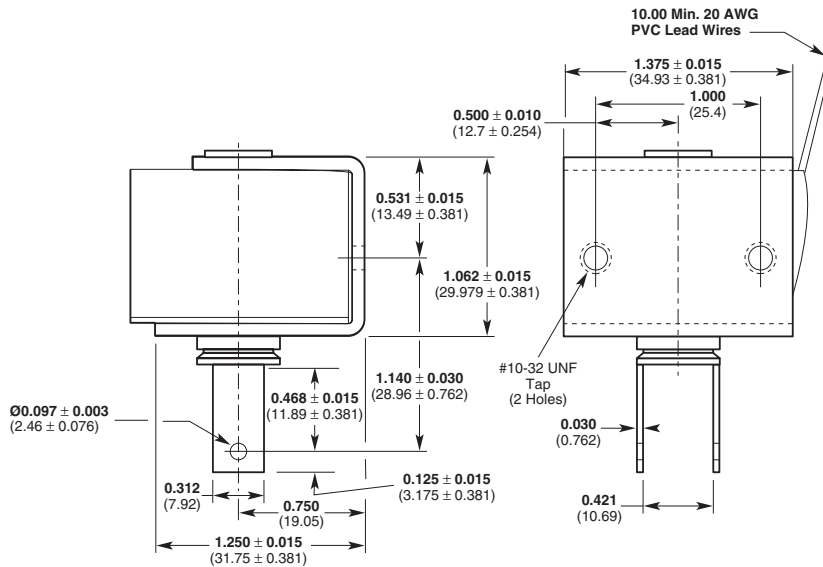

All specifications subject to change without notice.

Dormeyer® C Frame Dimensions

Inches (mm)

All solenoids are illustrated in energized state

NOTE: Many other metric and American standard threads are available.

C15

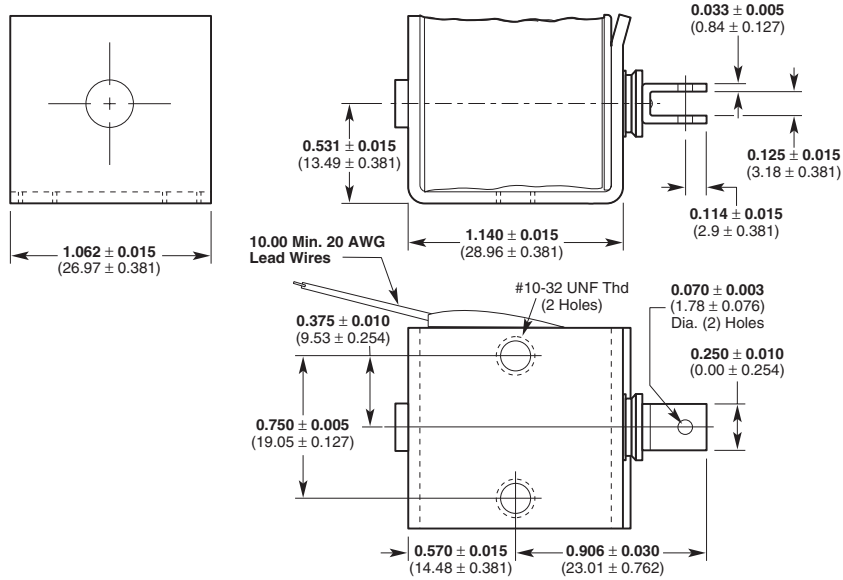

C26

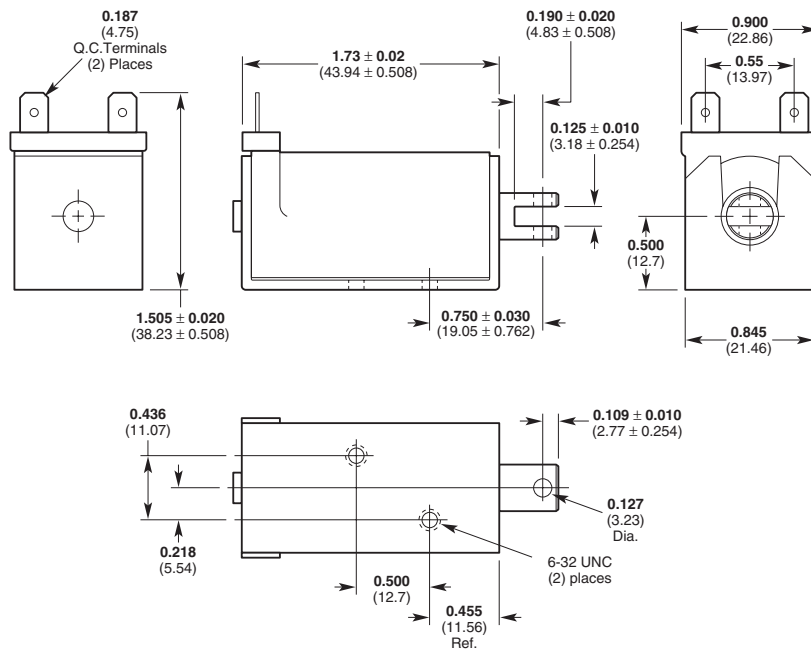

All specifications subject to change without notice.

Dormeyer® C Frame Dimensions

Inches (mm)

All solenoids are illustrated in energized state

NOTE: Many other metric and American standard threads are available.

C33

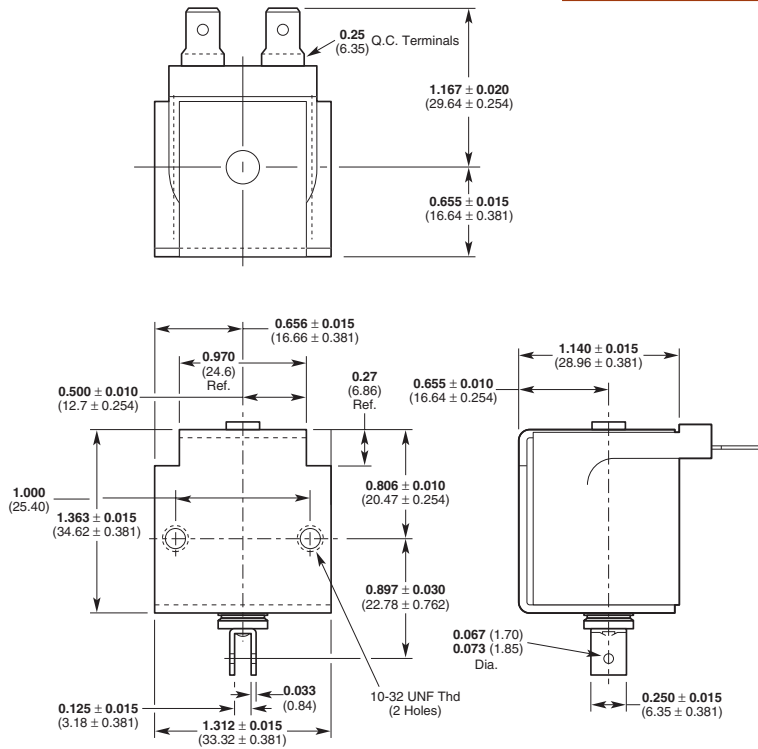

C34

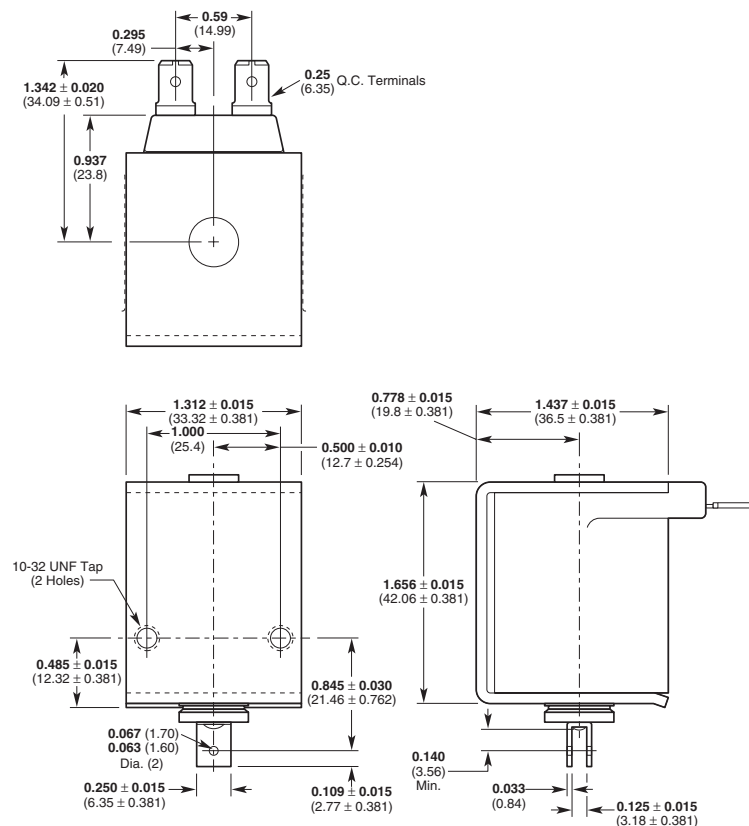

All specifications subject to change without notice.

Dormeyer® AC Laminates



- Low cost, high volume products
- Strokes to 1.25 inches (0.32 mm)
- Custom design work is our strength

Applications

- Commercial equipment
- Industrial doors
- Machine tools

All catalog products manufactured after
April 1, 2006 are RoHS Compliant

Laminates

This solenoid has a T-shaped laminated design plunger and laminated steel frame. It has the unique ability to hold an exceptionally heavy load with a minimum of humming or vibration.

To minimize the humming or chattering of most AC solenoids, the contact surfaces of the laminated frame and plunger are machined to provide a smooth and flush contact surface. Dormeyer Super-T Laminates are products of years of engineering, research and manufacturing experience.

Available in various frame sizes to meet most requirements for medium life as well as in a variety of plunger and coil arrangements, they are readily suited for most high force AC applications. These include appliances, business machines and vending machines.

The Super-T Series Laminates are tooled with provisions to modify the basic design and tooling to fit high volume applications at the lowest possible unit cost. Super-T Laminates can be supplied with fully encapsulated coils at the same price as taped coils.

Principle of Operation

Laminate solenoids consist of a laminated steel frame, a coil, and a movable plunger in the center of the coil. When the coil is energized the plunger is pulled into the coil.

Selection Overview

Use the selection chart on the following page to determine which model offers the desired performance and mechanical specifications. Refer to the individual frame size specification pages for complete performance and mechanical data.

Even with our many standard solenoid designs, our customers often require a product with unique features or performance capabilities. If you don't find what you're looking for in the catalog, please give us a call and talk to one of our application engineers.

Dormeyer® AC Laminates

Design Considerations

Life

When selecting an open frame solenoid, as with any other solenoid style, it is important to consider the effects of heat, since an increase in coil temperature reduces the work output and the life of the unit. Standard life is 50,000 to 100,000 operations. Consult the factory for longer life of 500,000 or more cycles, and other special requirements.

Duty Cycle

Duty cycle is determined by solenoid ON time/(ON + OFF time).

For example: a solenoid is actuated for 30 seconds, then off for 90 seconds.
 $30 \text{ sec ON} / (30 \text{ Sec ON} + 90 \text{ sec OFF}) = 30/120 = 1/4 \text{ or } 25\% \text{ duty cycle.}$

Performance Curves

The Force/Stroke performance curves in this section serve as guides to determine the solenoid size needed to produce a desired force at a given stroke, duty cycle, and power source. All Force/Stroke curves are performed under standard test conditions: ambient temperature of 20°C. A design safety factor of 1.5 to 1.5 is recommended. For example, when a 4.5 lb pull force is required, select a model with a safety factor of 1.5 to 1.5 times (5.8 to 6.7 lb).

Size	Frame Type	Coil Type ⁽¹⁾	Height (inches)	Width (inches)	Length (inches)	Max. Stroke (inches)	Nominal Stroke (inches)	Typical Force (lbs)		Page
								Nominal Stroke and 100% Rated Voltage @ 100% Duty	25% Duty	
1000	1/2" Stack	OM	1.44	1.19	1.61	0.75	0.375	2.0	3.0	32
1000	3/4" Stack	T	1.43	1.44	1.61	0.75	0.375	2.5	4.0	33
2000	3/4" Stack	OM	2.06	1.81	2.50	1.00	0.50	6.3	7.8	34
2000	1" Stack	OM	2.06	2.06	2.50	1.00	0.50	9.1	11.9	35
3000	1" Stack	OM	2.94	2.38	2.97	1.25	0.50	11.9	20.0	36

Dormeyer® Laminate Size 1000 (1/2" Stack) — AC Operation

Specifications

Continuous Duty Cycle	At 20°C ambient temperature
Intermittent Duty Cycle	20% on time. 80% off time. On time not to exceed 3 min. at 20°C ambient temperature
Coil Insulation	Class "A": 105°C max. temperature standard, Class "B" available on request
Coil Termination	Solder lugs
Plunger Variations	See page 37
Total Weight	6.5 oz. (184 g)
Dimensions	See page 37

All catalog products manufactured after April 1, 2006 are RoHS Compliant

AC Continuous Duty

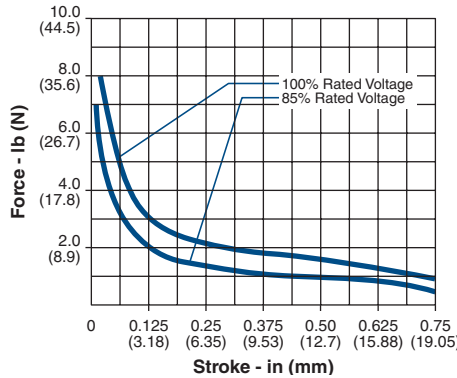

AC Intermittent Duty

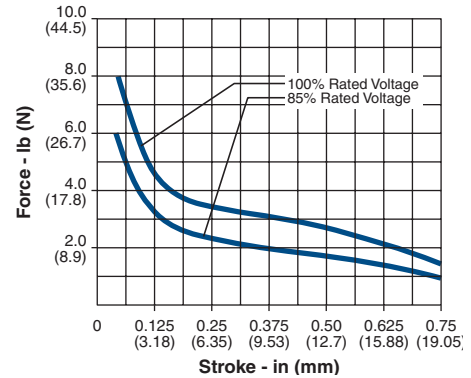

Duty Cycle	Continuous		Intermittent	
Model	1000-M-1	1001-M-1	1500-M-1	1501-M-1
Volts — 60Hz (50 Hz. avail.)	120	240	120	240
Coil Resistance ± 10% (Ohms at 25°C)	88	354	58	240
Watts Seated ± 10%	9.5	10.0	20.0	18.5
Amps Seated ± 10%	0.24	0.15	0.52	0.24
Amps at 1/8" ± 10%	0.72	0.38	1.20	0.53
Amps at 1/4" ± 10%	0.92	0.47	1.40	0.64
Amps at 3/8" ± 10%	1.00	0.52	1.70	0.76
Amps at 1/2" ± 10%	1.20	0.56	1.80	0.81
Amps at 5/8" ± 10%	1.22	0.60	1.90	0.84

NOTES:

- All data is typical.
- Pull values indicated are without plunger weight. Add or subtract 0.11 lbs. (0.5 N) to obtain net pull when operated with or against gravity. Force data: ±10%. Quiet seal pull: 4.5 oz. (1.2 N) at rated voltage.
- All data reflects operation with no heatsink.
- Other coil terminations available.
- All specifications subject to change without notice.

How to Order

Select the part number from the table provided. (For example, to order a continuous duty cycle unit rated at 120 VAC, specify 1000-M-1.

Please see www.ledex.com (click on Stock Products tab) for our list of stock products available through our distributors.

All specifications subject to change without notice.

Dormeyer® Laminate Size 1000 ($\frac{3}{4}$ " Stack) — AC Operation

Specifications

Continuous Duty Cycle	At 20°C ambient temperature
Intermittent Duty Cycle	20% on time, 80% off time. On time not to exceed 3 min. at 20°C ambient temperature
Coil Insulation	Class "A": 105°C max. temperature standard
Coil Termination	Solder lugs
Plunger Variations	See page 38
Average Total Weight	9.2 oz. (260 g)
Dimensions	See page 38

All catalog products manufactured after April 1, 2006 are RoHS Compliant

AC Continuous Duty

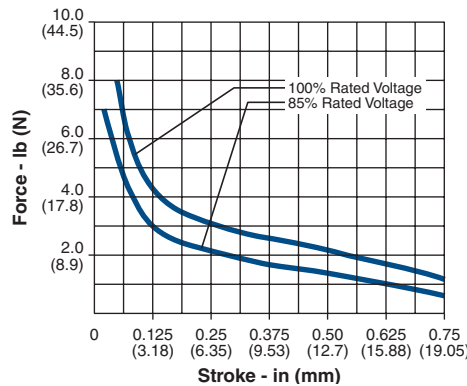

AC Intermittent Duty

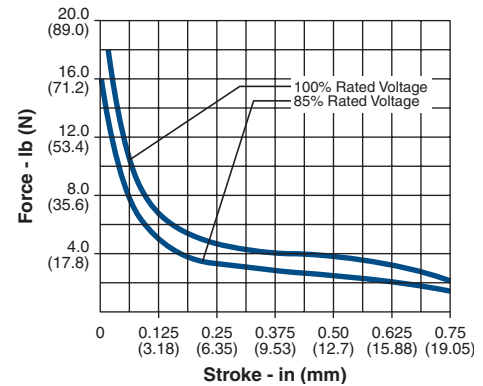

Duty Cycle	Continuous		Intermittent	
Model	1250-A-1	1251-A-1	1750-A-1	1751-A-1
Volts — 60Hz (50 Hz avail.)	120	240	120	240
Coil Resistance $\pm 10\%$ (Ohms at 25°C)	64	258	40.5	161
Watts Seated $\pm 10\%$	10.7	9.0	17.7	19.5
Amps Seated $\pm 10\%$	0.28	0.13	0.50	0.26
Amps at $\frac{1}{8}$ " $\pm 10\%$	0.96	0.44	1.40	0.72
Amps at $\frac{1}{4}$ " $\pm 10\%$	1.20	0.58	1.80	0.93
Amps at $\frac{3}{8}$ " $\pm 10\%$	1.40	0.63	2.10	1.10
Amps at $\frac{1}{2}$ " $\pm 10\%$	1.60	0.72	2.40	1.30
Amps at $\frac{5}{8}$ " $\pm 10\%$	1.70	0.78	2.60	1.40

NOTES:

- All data is typical.
- Pull values indicated are without plunger weight. Add or subtract 0.17 lbs. (0.8 N) to obtain net pull when operated with or against gravity. Force data: $\pm 10\%$.
- All data reflects operation with no heatsink.
- Other coil terminations available.
- All specifications subject to change without notice.

How to Order

Select the part number from the table provided. (For example, to order a continuous duty cycle unit rated at 120 VAC, specify 1250-A-1.

Please see www.ledex.com (click on Stock Products tab) for our list of stock products available through our distributors.

All specifications subject to change without notice.



Dormeyer® Laminate Size 2000 (3/4" stack) — AC Operation

Specifications

Continuous Duty Cycle	At 20°C ambient temperature
Intermittent Duty Cycle	20% on time, 80% off time. On time not to exceed 3 min. at 20°C ambient temperature
Coil Insulation	Class "F": 155°C max. temperature standard
Coil Termination	1/4" QC
Plunger Variations	See page 39
Average Total Weight	18 oz. (510 g)
Dimensions	See page 39

All catalog products manufactured after April 1, 2006 are RoHS Compliant

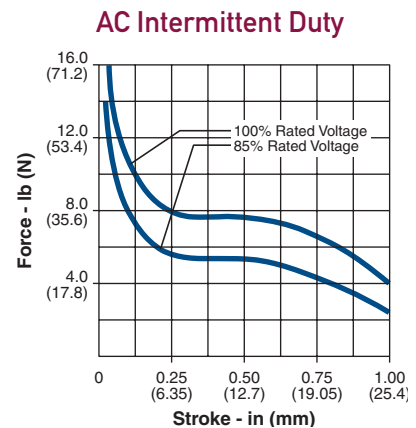
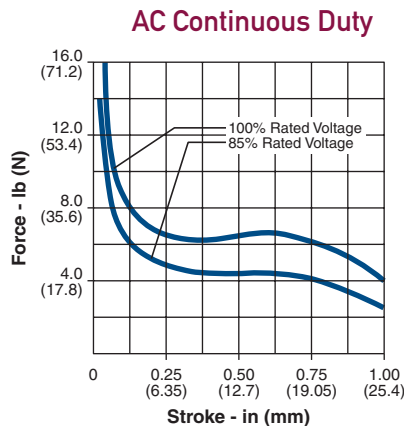

Duty Cycle	Continuous		Intermittent	
Model	2005-F-34	2006-F-34	2255-F-34	2256-F-34
Volts — 60Hz (50 Hz avail.)	120	240	120	240
Coil Resistance ± 10% (Ohms at 25°C)	20.5	82	18.3	73.5
Watts Seated ± 10%	17.9	17.5	23.5	23.8
Amps Seated ± 10%	0.43	0.22	0.64	0.32
Amps at 1/4" ± 10%	2.30	1.10	2.80	1.40
Amps at 1/2" ± 10%	3.30	1.60	4.00	2.00
Amps at 3/4" ± 10%	4.10	2.10	5.00	2.60
Amps at 1" ± 10%	4.90	2.50	6.00	2.90

NOTES:

- All data is typical.
- Pull values indicated are without plunger weight. Add or subtract 0.27 lbs. (1.2 N) to obtain net pull when operated with or against gravity. Force data: ±10%.
- All data reflects operation with no heatsink.
- Other coil terminations available.
- All specifications subject to change without notice.

How to Order

Select the part number from the table provided. (For example, to order a continuous duty cycle unit rated at 120 VAC, specify 2005-F-5.

Please see www.ledex.com (click on Stock Products tab) for our list of stock products available through our distributors.

All specifications subject to change without notice.

Dormeyer® Laminate Size 2000 (1" stack) — AC Operation

Specifications

Continuous Duty Cycle	At 20°C ambient temperature
Intermittent Duty Cycle	20% on time, 80% off time. On time not to exceed 3 min. at 20°C ambient temperature
Coil Insulation	Class "F": 155°C max. temperature standard
Coil Termination	1/4" QC
Plunger Variations	See page 40
Total Weight	22 oz. (623 g)
Dimensions	See page 40

All catalog products manufactured after April 1, 2006 are RoHS Compliant

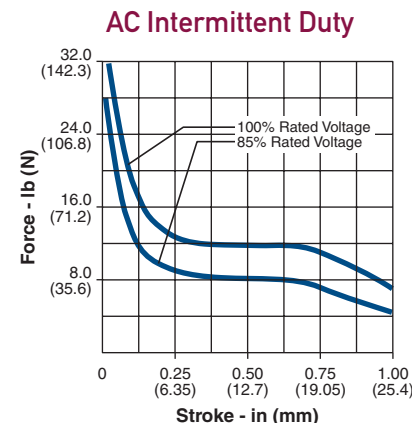
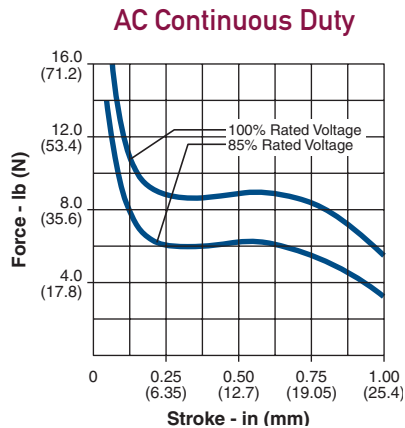

Duty Cycle	Continuous		Intermittent	
Model	2536-F-34	2537-F-34	2786-F-34	2787-F-34
Volts — 60Hz (50 Hz avail.)	120	240	120	240
Coil Resistance ± 10% (Ohms at 25°C)	14.8	60	11.7	48
Watts Seated ± 10%	19.0	18.0	36.5	36.0
Amps Seated ± 10%	0.48	0.24	0.95	0.48
Amps at 1/4" ± 10%	2.90	1.50	4.30	2.20
Amps at 1/2" ± 10%	4.40	2.20	6.00	3.00
Amps at 3/4" ± 10%	5.50	2.70	7.50	3.80
Amps at 1" ± 10%	6.50	3.20	8.50	4.30

NOTES:

- All data is typical.
- Pull values indicated are without plunger weight. Add or subtract 0.37 lbs. (0.1 N) to obtain net pull when operated with or against gravity. Force data: ±10%.
- All data reflects operation with no heatsink.
- Other coil terminations available.
- All specifications subject to change without notice.

How to Order

Select the part number from the table provided. (For example, to order a continuous duty cycle unit rated at 120 VAC, specify 2536-F-5.

Please see www.ledex.com (click on Stock Products tab) for our list of stock products available through our distributors.

All specifications subject to change without notice.



Dormeyer® Laminate Size 3000 (1" stack) — AC Operation

Specifications

Continuous Duty Cycle	At 20°C ambient temperature
Intermittent Duty Cycle	20% on time, 80% off time. On time not to exceed 3 min. at 20°C ambient temperature
Coil Insulation	Class "A": 105°C max. temperature standard
Coil Termination	Solder lugs
Plunger Variations	See page 41
Total Weight	43 oz. (1.2 kg)
Dimensions	See page 41

All catalog products manufactured after April 1, 2006 are RoHS Compliant

AC Continuous Duty

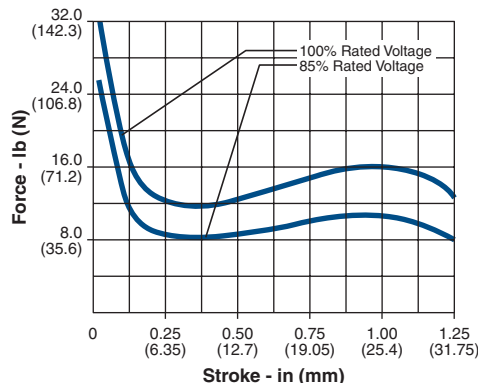

AC Intermittent Duty

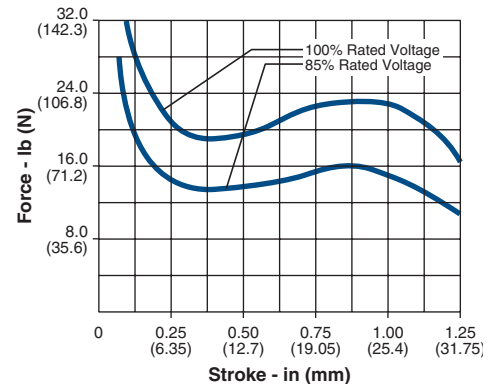

Duty Cycle	Continuous		Intermittent	
Model	3000-M-1	3001-M-1	3500-M-1	3501-M-1
Volts—60Hz (50 Hz avail.)	120	240	120	240
Coil Resistance ± 10% (Ohms at 25°C)	6.5	26	4.8	19.3
Watts Seated ± 10%	25.0	23.5	47.0	48.0
Amps Seated ± 10%	0.66	0.33	1.80	0.68
Amps at 1/4" ± 10%	3.80	1.80	6.50	3.20
Amps at 1/2" ± 10%	5.50	2.80	9.50	4.80
Amps at 3/4" ± 10%	7.50	3.90	13.00	6.60
Amps at 1" ± 10%	10.00	5.20	15.50	7.70
Amps at 1 1/4" ± 10%	12.00	6.50	17.00	8.50

NOTES:

- All data is typical.
- Pull values indicated are without plunger weight. Add or subtract 0.79 lbs. (3.5 g) to obtain net pull when operated with or against gravity. Force data: ±10%.
- All data reflects operation with no heatsink.
- Other coil terminations available.
- All specifications subject to change without notice.

How to Order

Select the part number from the table provided. (For example, to order a continuous duty cycle unit rated at 120 VAC, specify 3000-M-1.

Please see www.ledex.com (click on Stock Products tab) for our list of stock products available through our distributors.

All specifications subject to change without notice.



Dormeyer® Laminate Dimensions

Inches (mm)

All solenoids are illustrated in energized state

Size 1000 (1/2" Stack)

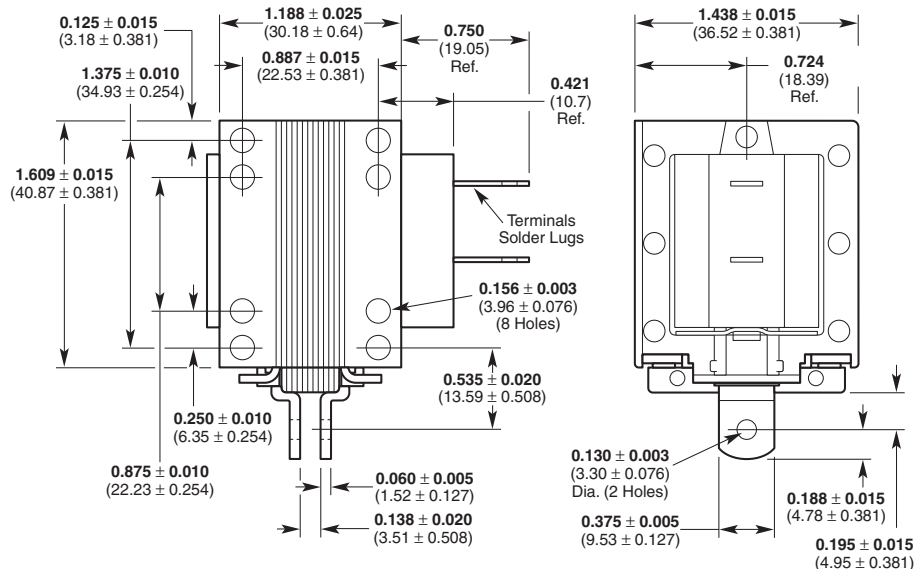

Size 1000 (1/2" Stack) Plunger Variations

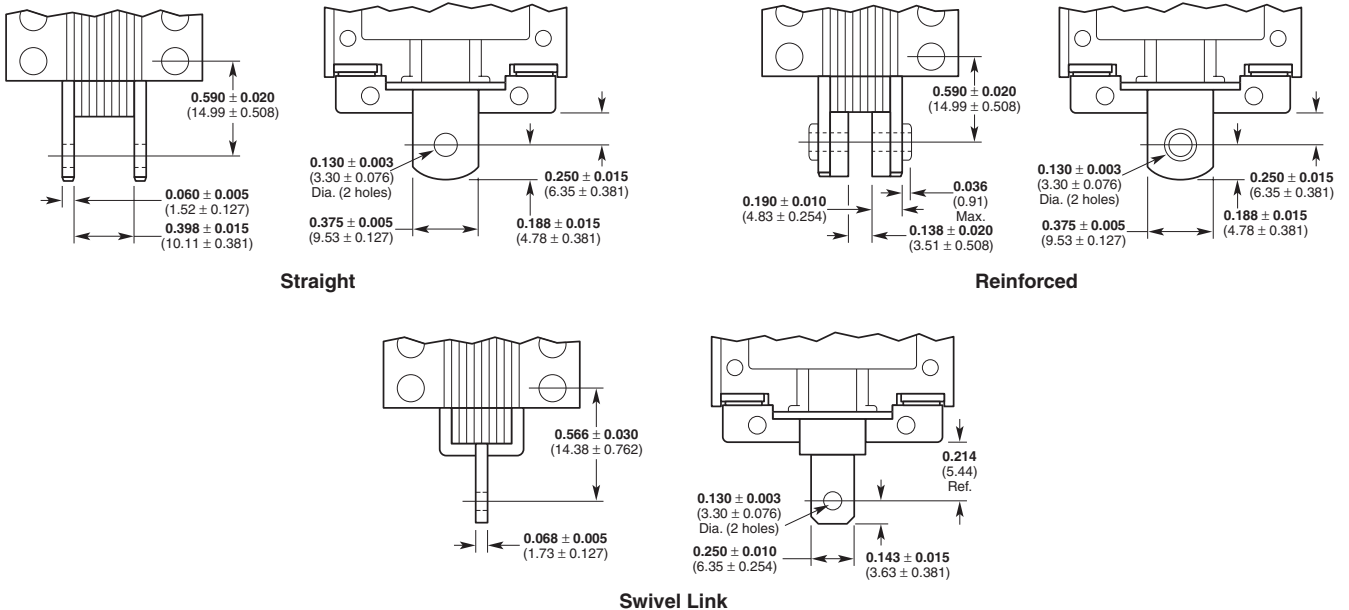

All specifications subject to change without notice.

Dormeyer® Laminate Dimensions

Inches (mm)

All solenoids are illustrated in energized state

Size 1000 (3/4" Stack)

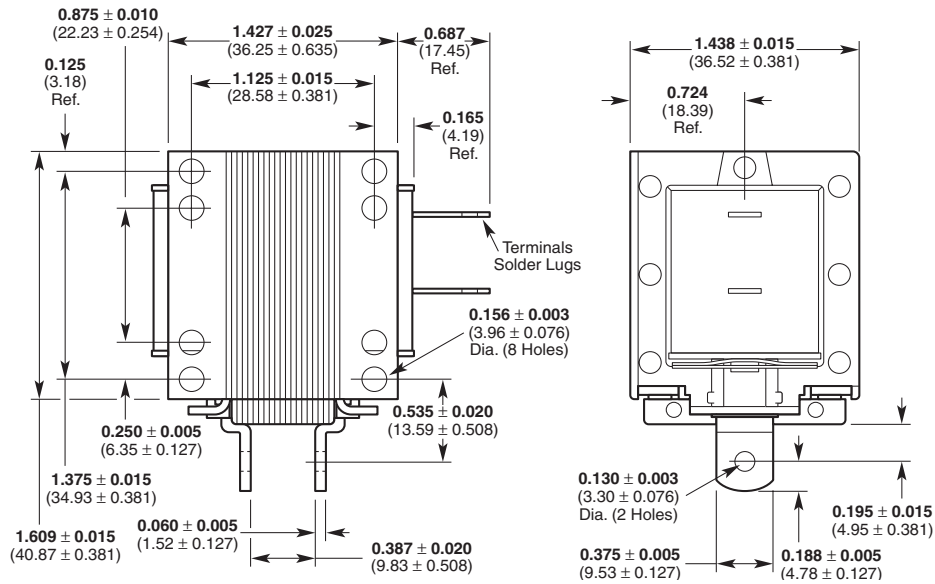

Size 1000 (3/4" Stack) Plunger Variations

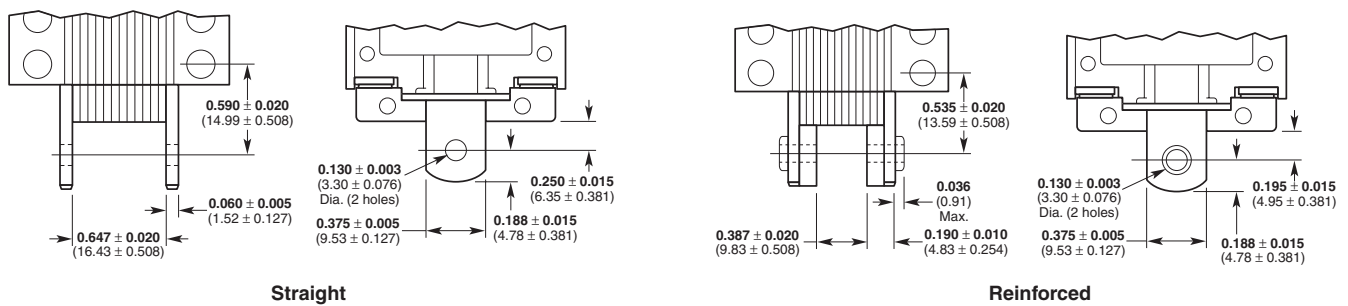

All specifications subject to change without notice.

Dormeyer® Laminate Dimensions

Inches (mm)

All solenoids are illustrated in energized state

Size 2000 (3/4" Stack)

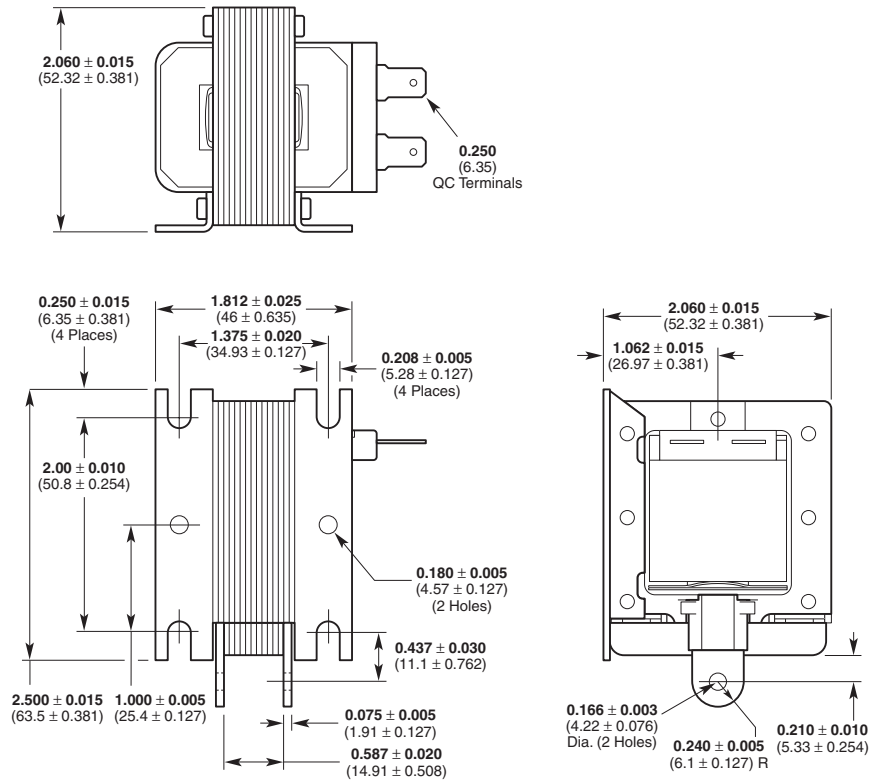

Size 2000 (3/4" Stack) Plunger Variations

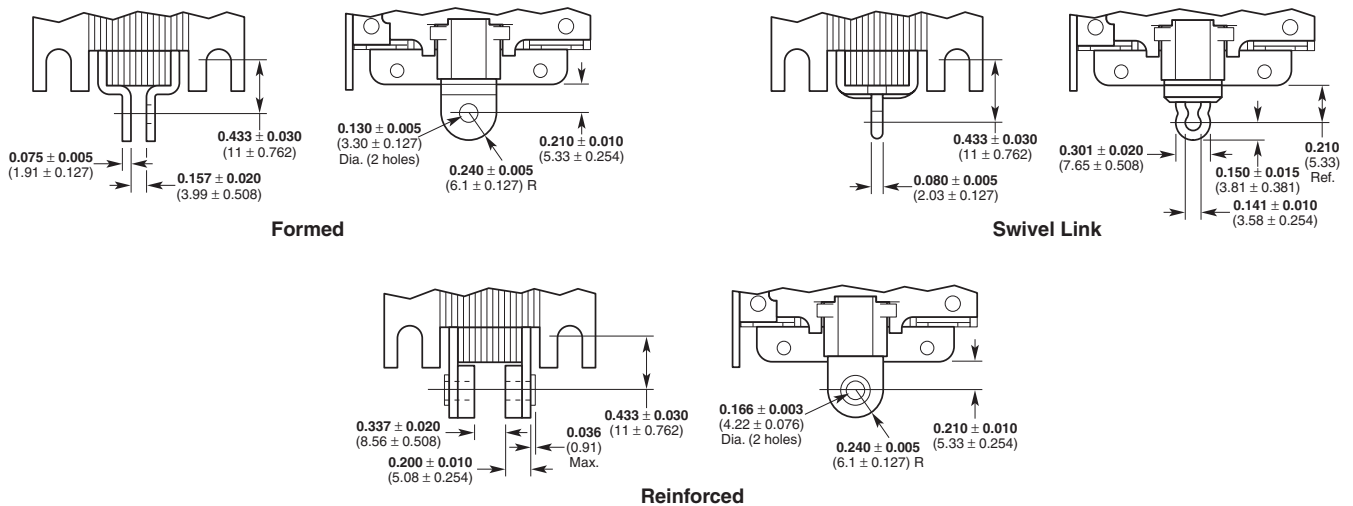

All specifications subject to change without notice.

Dormeyer® Laminate Dimensions

Inches (mm)

All solenoids are illustrated in energized state

Size 2000 (1" Stack)

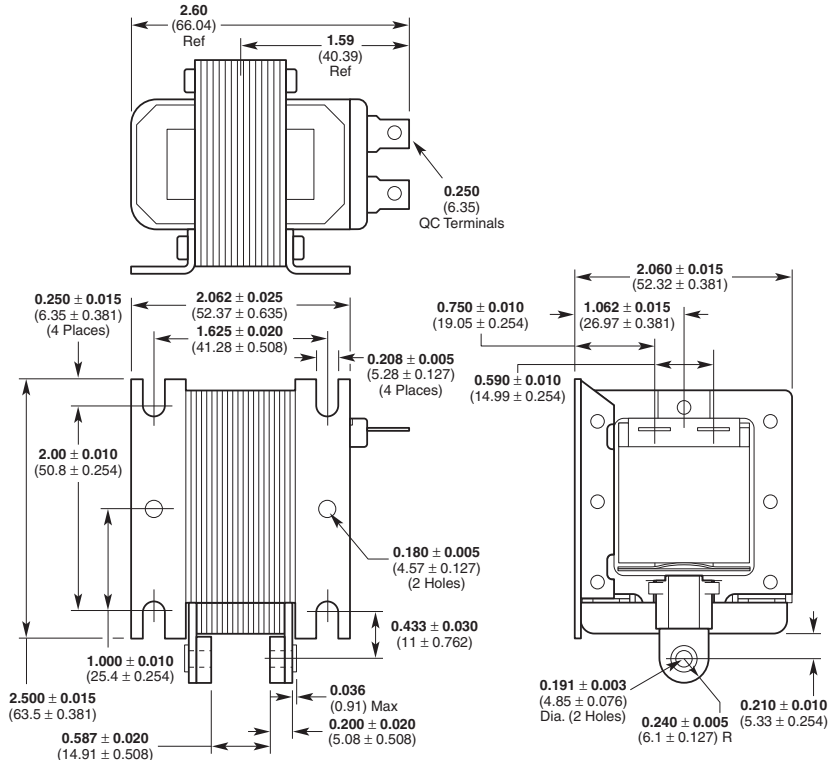

Size 2000 (1" Stack) Plunger Variations

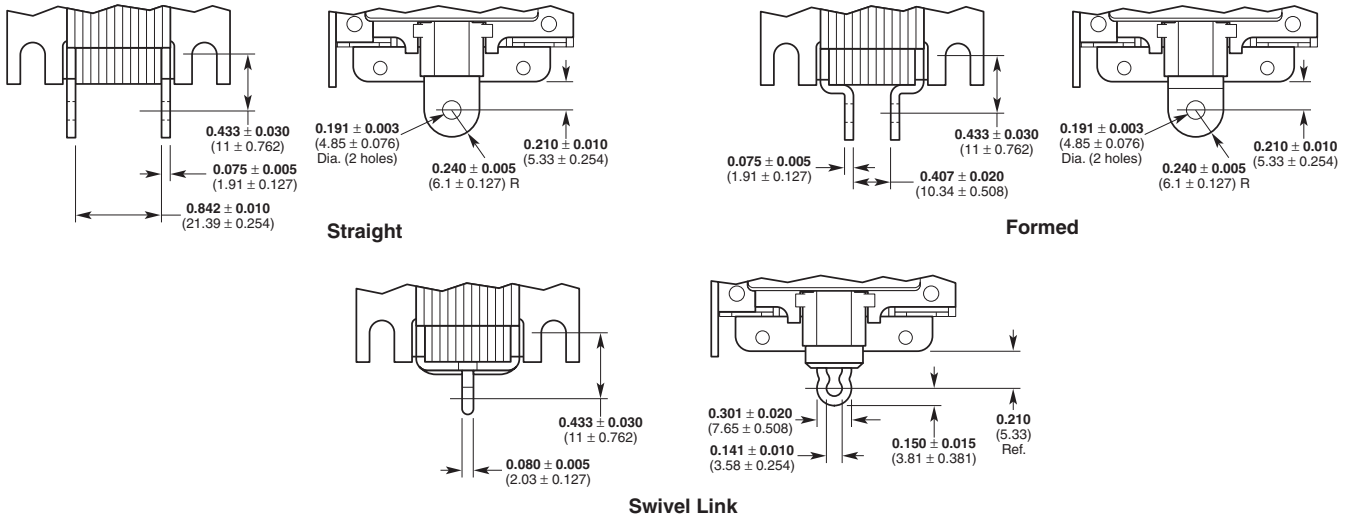

All specifications subject to change without notice.

Dormeyer® Laminate Dimensions

Inches (mm)

All solenoids are illustrated in energized state

Size 3000 (1" Stack)

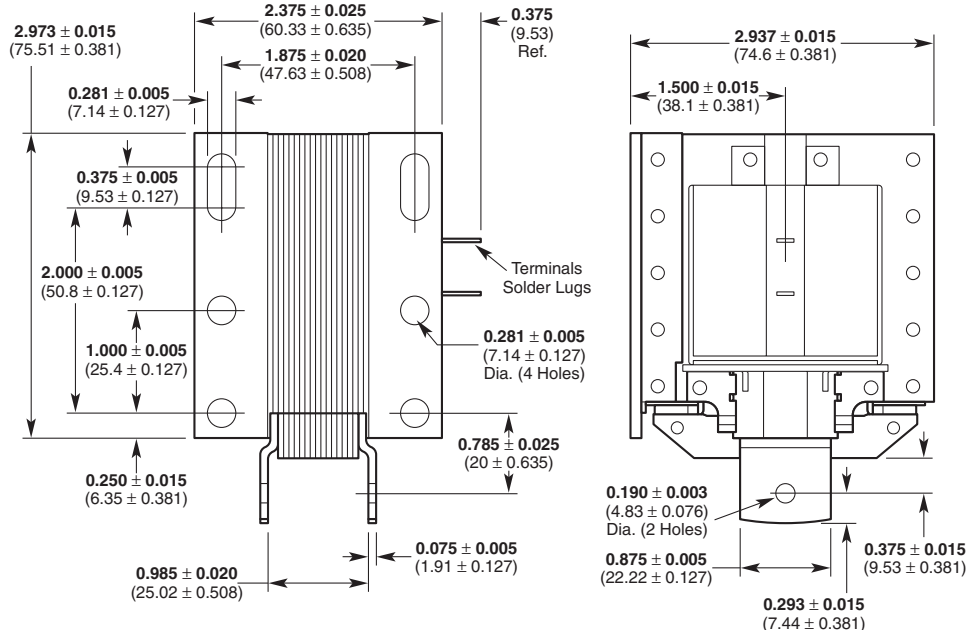

Size 3000 (1" Stack) Plunger Variations

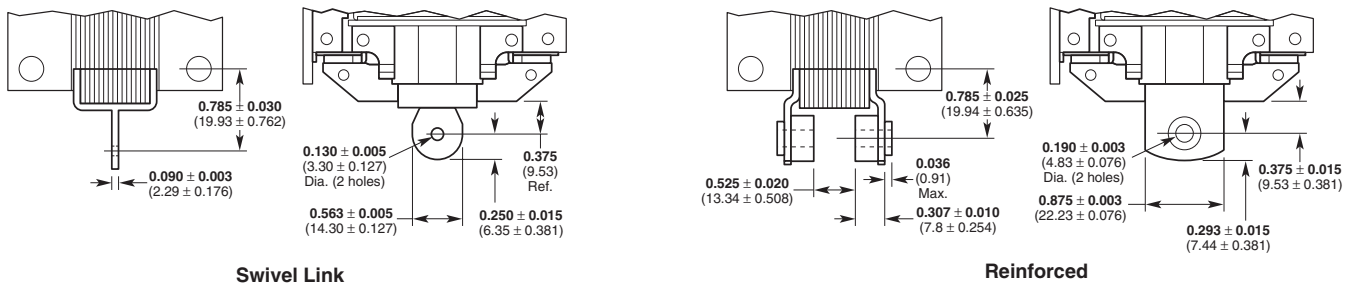

All specifications subject to change without notice.

Technical Data

A solenoid is a basic, rugged device. Its component parts consist of a coil (to carry current and generate ampere turns), an iron shell or case (to provide a magnetic circuit), and a movable plunger or pole (to act as the working element).

A major objective in the design of a solenoid is to provide an iron path capable of transmitting maximum magnetic flux density with a minimum energy input. Another objective is to get the best relationship between the variable ampere turns and the working flux density in the air gap. When applying a solenoid, it is extremely important to consider the effects of heat, since for a constant voltage application, an increase in coil temperature reduces the work output.

Ambient temperature range, voltage fluctuation, return springs and temperature rise all affect the net output torque/force. For preliminary calculations, we recommend that a 1.5 safety factor be applied to the variables.

Magnetic Flux

Magnetic flux lines are transmitted through the iron shell and the air gap between the shell and the plunger (for linear solenoids) or the armature (for rotary solenoids). An iron path is much more efficient than air, but the air gap is needed to permit movement of the plunger or armature.

The force or torque of a given solenoid is inversely proportional to the square of the distance between the pole faces. The lowest force or torque is generated when the distance is widest/longest; the strongest when the distance is smallest.

Saturation

Saturation of the iron path in a solenoid can be considered in two ways. In the true sense it is point (a) at which the iron ceases to carry any increase in flux. In broader terms, saturation is usually considered as point (b), where the iron begins to saturate.

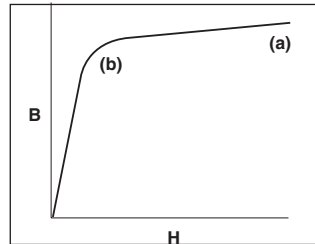

As the pole pieces are moved together or when input power is increased, the flux density of the magnetic circuit increases until the iron saturates near point (b). Beyond this point any further increase in power only serves to add heat without an appreciable increase in force or torque. By changing the iron path area, the pole shape, or the magnetic circuit material, output torque/force can be increased.

Ampere Turns

The number of copper wire turns, the magnitude of the current, and permeance of the magnetic circuit determine the absolute value of magnetic flux within the solenoid. The permissible temperature rise limits the magnitude of the power input. When using a constant voltage, heat makes the coil less efficient because it reduces the ampere turns and, hence, the flux density and the torque/force output.

Heat

Heat can be dissipated by controlling the air flow, by mounting the solenoid on a surface large enough to dissipate the energy (heat sink), or by resorting to some other cooling method.

When space permits, a simple solution is to use a larger solenoid. Heat in a solenoid is a function of power and the time during which power is applied. For continuous duty, hold-in resistor circuits are commonly used to provide higher starting torques/forces than are obtainable at continuous duty rating.

Our stock model standard solenoids are designed to operate in ambient temperatures of -55°C to 80°C. A solenoid operating at the predetermined conditions established in the coil data charts, with the specified heat sink, will have a coil temperature rise of about 80°C (above ambient temperature). Our standard solenoids will withstand 120°C without thermal damage. A special high temperature coil with a 175°C temperature limit, for operation in up to 95°C ambient, is available for rotary and low profile solenoids.

Duty Cycle

Duty cycle is determined by ON time/(ON + OFF) time. For example, if a solenoid is energized one second out of four seconds, the duty cycle is $1/(1 + 3) = 1/4$ or 25%. Duty cycle is the time factor which determines the permissible watts input and the subsequent amount of torque/force and heat. If, for example, a 10-watt input power causes a heat rise of 20°C in 10 seconds, approximately the same temperature rise will result if a power of 100 watts is applied for one second. In terms of duty cycle, a solenoid designed for continuous duty can dissipate ten times the input power at 10% duty.

Maximum ON Time

Solenoids have a maximum ON time for a given duty cycle, wattage and power input. For example, if a solenoid is energized for one second out of four (25% duty cycle), its ON time is one second, which will cause no damage. On the other hand, if the solenoid is energized for 10 minutes out of every 40 minutes at the 25% duty cycle wattage, the duty cycle is still 25%, but its ON time is now 600 seconds. A single pulse of this duration would burn out the solenoid. Ledex and Dormeyer DC solenoids are specified with two criteria for maximum ON time: when pulsed repeatedly at the stated watts and duty cycle, and; for a single pulse at the stated watts (with the coil at 20°C ambient temperature).

Operating Speed

The energizing time for a solenoid to complete a given stroke is measured from the beginning of the initial pulse to the seated or energized position. For a given solenoid, this time is dependent upon the load, duty cycle, input power, stroke and temperature range.

Environmental Considerations

Factors which impact the operation and performance of solenoids include:

- Temperature
 - Sand and dust
 - Humidity
 - Shock and vibration
 - Altitude, vacuum and pressure
 - Specific application considerations such as paper dust and exposure to certain chemicals
- Please consult an application engineer, if any of these factors are prominent in your planned solenoid design.

Technical Glossary of Terms

Air Gap

The air space between the armature hub and the base or the air space between the stationary and the moveable pole piece.

Ampere Turns

The absolute value of magnetic flux determined by the number of copper wire turns in the coil and the magnitude of the current.

Permissible temperature rise of the coil limits the magnitude of the power input. Heat makes the coil less efficient because it reduces the ampere turns and hence the flux density and the torque or force output

Armature Assembly

The assembly consisting of the armature plate, the hub, and the shaft which is the complete moving element in a rotary solenoid.

B-H Curve

The graph of the ratio of flux density to magnetic field intensity. The magnetic field intensity is usually plotted logarithmically. plate and the case.

Bobbins

Most bobbins are made of nylon 6/6 and meet UL file #E-41938 or E-39806B.

Bobbin Wound Coil

A coil, usually random wound on a spool which maintains the form and shape of the coil and also provides the coil insulation.

Case

The outer shell and main component of the solenoid coil housing. Made of CRS #1008, #1010, 12L14 or 1215 case hardened to 513 on the Vickers scale (RC50) for sizes 0 to 6 (sizes 7 and 8 are not case hardened). The case has the three coined ball races, and is formed from flat stock drawn into a cup (size 7 is machined from bar stock and size 8 is made from tubing stock because of their size and thickness).

Coil

Copper windings providing the electrical element of the solenoid through which current is passed to generate a magnetic field. Coils may be precision wound which allows the maximum amount of copper in the space provided or random wound or bobbin wound.

Dielectric

Dielectric is the resistance between the coil and the case. Minimum dielectric value is 500 VRMS and range up to 1,500 VRMS depending on the solenoid size type and wire gage. Dielectric values are shown for each solenoid in the specifications chart.

Duty Cycle

ON Time/ON+OFF Time = Duty Cycle. Standard duty cycles used in this catalog are 100%, 50%, 25%, 10% and 5%. Other values can be determined by interpolation between any two columns.

Flux Density

The number of Webers per square meter in a cross section normal to the direction of the flux. This quantity is known as Tesla and given the symbol B. The typical knee in the B-H curve where iron becomes difficult to further magnetize is around 1.6 Tesla.

Flux, Magnetic

The physical manifestation of a condition existing in a medium or material subjected to a magnetizing influence. The quantity is characterized by the fact that an electromotive force is induced in a conductor surrounding the flux during any time there is a change in flux magnitude. A unit of flux is a Weber which is defined as that which being linearly attenuated to zero in 1 second, induces in a surrounding turn, an EMF of 1 volt.

Heat Rise

The rise in temperature which results from operating the solenoid at the predetermined conditions established in the coil data charts, with the specified heat sink. Standard solenoids will have a temperature rise of 80°C over ambient.

Heat Sink

The maximum allowable watts for each solenoid are based on an unrestricted flow of air at 20°C with the solenoid mounted on the equivalent heat sink specified for each size. Inadequate heat sink or restricted air flow may result in overheating of the solenoid.

Impedance

The total opposition to the flow of current in an a.c. solenoid. Impedance includes the effects of the d.c. resistance and the inductive reactance. Impedance, resistance and inductive reactance are measured in ohms.

Inductance

An electrical property of solenoids from which can be calculated the current rise time, the stored magnetic energy, the inductive reactance and the impedance. Inductance is an electrical energy storage unit (analogous to capacitance) and is measured in henrys.

Inductive Reactance

The opposition to a.c. current in a coil caused by its resulting magnetic field. Inductive reactance is measured in ohms.

Inrush Current

The initial coil current to an a.c. solenoid at the moment of turn-on when the solenoid plunger is in its de-energized position. Inrush current is caused by the large air gap of the de-energized plunger which produces a low coil impedance. When energized, the impedance increases significantly to reduce the coil current.

Technical Glossary of Terms

Lead Wires

Standard temperature rated coils use PVC insulated stranded lead wire, UL style 1007 rated for 80°C at 300 volts. It also meets CSA type TR-64, 90°C at 600 volts; and MIL-W-16878/2, 105°C at 1000 volts. High temperature coils use Teflon Type E, TFE, and meets MIL-W-16878/4A rated at 200°C at 600 volts.

Magnet Wire

100% copper wire, UL-recognized, single film insulation rated at 200°C (NEMA MW 35C or 155°C (NEMA MW 80C).

Magnetic Field Intensity

The closed loop integral of this quantity is equal to the total current enclosed, as defined by Maxwell's equation. Or, the magnetomotive force per unit length in a magnetic circuit. This quantity is given the symbol H.

Magnetomotive Force

See ampere turns.

Permeability

The ratio of flux density in a given medium to the magnetic field intensity. The symbol used is μ and has the value of $4\pi E-7$ in a vacuum.

Permeance

The ratio of the flux through any given cross section of a given medium (bounded by equipotential surfaces) to the difference in magnetomotive force between the two surfaces.

Plunger

The magnetic moving component of a linear solenoid, typically made from cold, rolled steel.

Random Wound Coil

A coil whose turns are allowed to wind randomly in no specific pattern. One turn may overlap another or may lay side by side or even spiral completely across the surface of the coil. Normally carries a $\pm 10\%$ tolerance on resistance

Relative Permeability

The ratio of the flux density in a given medium to that which would be produced in a vacuum with the same magnetizing force. Non-magnetic materials, including air, have a relative permeability of 1, while magnetic materials such as iron, have initial relative permeabilities of around 2,000.

Residual Magnetism

The magnetism which remains in effect on a piece of magnetic material or between two pieces of magnetic material after the electromagnetic field created by the coil has been removed. An air gap is usually maintained between two magnetic poles to minimize the effects of residual magnetism.

Return Springs

Return springs are an available feature on any solenoid.

Safety Factor

The ambient temperature range, voltage fluctuation, return springs and temperature rise all affect the net available output torque or force of a solenoid. A 1.5 safety factor should be applied to preliminary calculations of torque or force.

Shaft

The main axle of the solenoid which runs from the armature through the base and out the bottom and provides the main bearing. The shaft is also used for external attachment to the solenoid. Normally made of non-magnetic #303 stainless steel. On long-life rotary solenoid models the shaft is made of CRS #12L14 or 1215 which has been case hardened in the bearing area for wear resistance.

Stator Assembly

That portion of any solenoid which contains the coil, case and base. This portion remains stationary during operation.

Tape

Coil wrapping tape is clear Mylar brand polyester film 0.002" thick which has been slit to the desired width and is used to wrap the coil in an overlapping manner. The film is per Mil-I--631 Type G, Form T_p Class I, rated for 130°C continuous and meets UL file #E-59505. Coil banding tape is Mylar polyester film, adhesive backed per Mil-I-15126 Type MFT. This tape is used to wrap around the O.D. of the coil one thickness of 0.0025".

Technical Copper Resistance Factors

Because the resistance of copper wire varies with temperature, a given resistance must be compensated for when it is measured at some other temperature. The chart below can be used to determine the resistance at

different temperatures or the temperature if the resistance is known. (See Temperature and Force/Resistance Factor on page L3 for Resistance calculations.)

°C	°F	R.F.	°C	°F	R.F.	°C	°F	R.F.	°C	°F	R.F.
-55	-67.0	0.70525	0	32.0	0.92140	60	140.0	1.15720	120	248.0	1.39300
-54	-65.2	0.70918	1	33.8	0.92533	61	141.8	1.16113	121	249.8	1.39693
-53	-63.4	0.71311	2	35.6	0.92926	62	143.6	1.16506	122	251.6	1.40086
-52	-61.6	0.71704	3	37.4	0.93319	63	145.4	1.16899	123	253.4	1.40479
-51	-59.8	0.72097	4	39.2	0.93712	64	147.2	1.17292	124	255.2	1.40872
-50	-58.0	0.72490	5	41.0	0.94105	65	149.0	1.17685	125	257.0	1.41265
-49	-56.2	0.72883	6	42.8	0.94498	66	150.8	1.18078	126	258.8	1.41658
-48	-54.4	0.73276	7	44.6	0.94891	67	152.6	1.18471	127	260.6	1.42051
-47	-52.6	0.73669	8	46.4	0.95284	68	154.4	1.18864	128	262.4	1.42444
-46	-50.8	0.74062	9	48.2	0.95677	69	156.2	1.19257	129	264.2	1.42837
-45	-49.0	0.74455	10	50.0	0.96070	70	158.0	1.19650	130	266.0	1.43230
-44	-47.2	0.74848	11	51.8	0.96463	71	159.8	1.20043	131	267.8	1.43623
-43	-45.4	0.75241	12	53.6	0.96856	72	161.6	1.20436	132	269.6	1.44016
-42	-43.6	0.75634	13	55.4	0.97249	73	163.4	1.20829	133	271.4	1.44409
-41	-41.8	0.76027	14	57.2	0.97642	74	165.2	1.21222	134	273.2	1.44802
-40	-40.0	0.76420	15	59.0	0.98035	75	167.0	1.21615	135	275.0	1.45195
-39	-38.2	0.76813	16	60.8	0.98428	76	168.8	1.22008	136	276.8	1.45588
-38	-36.4	0.77206	17	62.6	0.98821	77	170.6	1.22401	137	278.6	1.45981
-37	-34.6	0.77599	18	64.4	0.99214	78	172.4	1.22794	138	280.4	1.46374
-36	-32.8	0.77992	19	66.2	0.99607	79	174.2	1.23187	139	282.2	1.46767
-35	-31.0	0.78385	20	68.0	1.00000	80	176.0	1.23580	140	284.0	1.47160
-34	-29.2	0.78778	21	69.8	1.00393	81	177.8	1.23973	141	285.8	1.47553
-33	-27.4	0.79171	22	71.6	1.00786	82	179.6	1.24366	142	287.6	1.47946
-32	-25.6	0.79564	23	73.4	1.01179	83	181.4	1.24759	143	289.4	1.48339
-31	-23.8	0.79957	24	75.2	1.01572	84	183.2	1.25152	144	291.2	1.48732
-30	-22.0	0.80350	25	77.0	1.01965	85	185.0	1.25545	145	293.0	1.49125
-29	-20.2	0.80743	26	78.8	1.02358	86	186.8	1.25938	146	294.8	1.49518
-28	-18.4	0.81136	27	80.6	1.02751	87	188.6	1.26331	147	296.6	1.49911
-27	-16.6	0.81529	28	82.4	1.03144	88	190.4	1.26724	148	298.4	1.50304
-26	-14.8	0.81922	29	84.2	1.03537	89	192.2	1.27117	149	300.2	1.50697
-25	-13.0	0.82315	30	86.0	1.03930	90	194.0	1.27510	150	302.0	1.51090
-24	-11.2	0.82708	31	87.8	1.04323	91	195.8	1.27903	151	303.8	1.51483
-23	-9.4	0.83101	32	89.6	1.04716	92	197.6	1.28296	152	305.6	1.51876
-22	-7.6	0.83494	33	91.4	1.05109	93	199.4	1.28689	153	307.4	1.52269
-21	-5.8	0.83887	34	93.2	1.05502	94	201.2	1.29082	154	309.2	1.52662
-20	-4.0	0.84280	35	95.0	1.05895	95	203.0	1.29475	155	311.0	1.53055
-19	-2.2	0.84673	36	96.8	1.06288	96	204.8	1.29868	156	312.8	1.53448
-18	-0.4	0.85066	37	98.6	1.06681	97	206.6	1.30261	157	314.6	1.53841
-17	1.4	0.85459	38	100.4	1.07074	98	208.4	1.30654	158	316.4	1.54234
-16	3.2	0.85852	39	102.2	1.07467	99	210.2	1.31047	159	318.2	1.54627
-15	5.0	0.86245	40	104.0	1.07860	100	212.0	1.31440	160	320.0	1.55020
-14	6.8	0.86638	41	105.8	1.08253	101	213.8	1.31833	161	321.8	1.55413
-13	8.6	0.87031	42	107.6	1.08646	102	215.6	1.32226	162	323.6	1.55806
-12	10.4	0.87424	43	109.4	1.09039	103	217.4	1.32619	163	325.4	1.56199
-11	12.2	0.87817	44	111.2	1.09432	104	219.2	1.33012	164	327.2	1.56592
-10	14.0	0.88210	45	113.0	1.09825	105	221.0	1.33405	165	329.0	1.56985
-9	15.8	0.88603	46	114.8	1.10218	106	222.8	1.33798	166	330.8	1.57378
-8	17.6	0.88996	47	116.6	1.10611	107	224.6	1.34191	167	332.6	1.57771
-7	19.4	0.89389	48	118.4	1.11004	108	226.4	1.34584	168	334.4	1.58164
-6	21.2	0.89782	49	120.2	1.11397	109	228.2	1.34977	169	336.2	1.58557
-5	23.0	0.90175	50	122.0	1.11790	110	230.0	1.35370	170	338.0	1.58950
-4	24.8	0.90568	51	123.8	1.12183	111	231.8	1.35763	171	339.8	1.59343
-3	26.6	0.90960	52	125.6	1.12576	112	233.6	1.36156	172	341.6	1.59736
-2	28.4	0.91354	53	127.4	1.12969	113	235.4	1.36549	173	343.4	1.60129
-1	30.2	0.91747	54	129.2	1.13362	114	237.2	1.36942	174	345.2	1.60522
			55	131.0	1.13755	115	239.0	1.37335	175	347.0	1.60915
			56	132.8	1.14148	116	240.8	1.37728	176	348.8	1.61308
			57	134.6	1.14541	117	242.6	1.38121	177	350.6	1.61701
			58	136.4	1.14934	118	244.4	1.38514	178	352.4	1.62094
			59	138.2	1.15327	119	246.2	1.38907	179	354.2	1.62487



Part Numbers in Distribution*

Box Frame Stock Parts

Product	Model/Size	Page
B4HD	B4HD-1-M-36	13
BHD	B4HD-501-M-36	13
B11	B11-1-M-36	14
B11	B11-501-M-36	14
B22	B22-1-M-36	17
B22	B22-501-M-36	17

C Frame Stock Parts

Product	Model/Size	Page
C8	C8-19-M-36	18
C8	C8-519-M-36	18
C26	C26-19-M-36	21
C26	C26-519-M-36	21
C33	C33-19-M-33	22
C33	C33-519-M-33	22
C34	C34-19-M-33	23
C34	C34-519-M-33	23



ERMEC, S.L. BARCELONA
C/ Francesc Teixidó, 22
E-08918 Badalona
(Spain)

Tel.: (+34) 902 450 160
Fax: (+34) 902 433 088
info@ermec.com
www.ermec.com

ERMEC, S.L. MADRID
C/ Sagasta, 8, 1ª planta
E-28004 Madrid
(Spain)

PORTUGAL
portugal@ermec.com
BILBAO
bilbao@ermec.com

*Parts typically found in Distribution. Contact your local distributor, or see our website for the distributor nearest you.



Dormeyer www.dormeyer.com

www.ermec.com

Index of Part Numbers

Open Frame Products

Part Number	Product	Page
B4HD-1-M-36	Box Frame, AC Operation	13
B4HD-2-M-36	Box Frame, AC Operation	13
B4HD-501-M-36	Box Frame, AC Operation	13
B4HD-502-M-36	Box Frame, AC Operation	13
B11-1-M-36	Box Frame, AC Operation	14
B11-2-M-36	Box Frame, AC Operation	14
B11-501-M-36	Box Frame, AC Operation	14
B11-502-M-36	Box Frame, AC Operation	14
B20-1-A-3	Box Frame, AC Operation	15
B20-2-A-3	Box Frame, AC Operation	15
B20-501-A-3	Box Frame, AC Operation	15
B20-502-A-3	Box Frame, AC Operation	15
B21-1-A-3	Box Frame, AC Operation	16
B21-2-A-3	Box Frame, AC Operation	16
B21-501-A-3	Box Frame, AC Operation	16
B21-502-A-3	Box Frame, AC Operation	16
B22-1-M-36	Box Frame, AC Operation	17
B22-2-M-36	Box Frame, AC Operation	17
B22-501-M-36	Box Frame, AC Operation	17
B22-502-M-36	Box Frame, AC Operation	17
C8-19-M-36	C Frame, AC Operation	18
C8-20-M-36	C Frame, AC Operation	18
C8-519-M-36	C Frame, AC Operation	18
C8-520-M-36	C Frame, AC Operation	18
C9-19-A-3	C Frame, AC Operation	19
C9-20-A-3	C Frame, AC Operation	19
C9-519-A-3	C Frame, AC Operation	19
C9-520-A-3	C Frame, AC Operation	19
C15-19-B-36	C Frame, AC Operation	20
C15-20-B-36	C Frame, AC Operation	20
C15-519-B-36	C Frame, AC Operation	20
C15-520-B-36	C Frame, AC Operation	20
C26-19-M-36	C Frame, AC Operation	21
C26-20-M-36	C Frame, AC Operation	21
C26-519-M-36	C Frame, AC Operation	21
C26-520-M-36	C Frame, AC Operation	21
C33-19-M-33	C Frame, AC Operation	22
C33-20-M-33	C Frame, AC Operation	22
C33-519-M-33	C Frame, AC Operation	22
C33-520-M-33	C Frame, AC Operation	22
C34-19-M-33	C Frame, AC Operation	23
C34-20-M-33	C Frame, AC Operation	23
C34-519-M-33	C Frame, AC Operation	23
C34-520-M-33	C Frame, AC Operation	23

Laminate Products

Part Number	Product	Page
1000-M-1	Laminate Solenoid	32
1001-M-1	Laminate Solenoid	32
1250-A-1	Laminate Solenoid	33
1251-A-1	Laminate Solenoid	33
1500-M-1	Laminate Solenoid	32
1501-M-1	Laminate Solenoid	32
1750-A-1	Laminate Solenoid	33
1751-A-1	Laminate Solenoid	33
2005-F-34	Laminate Solenoid	34
2006-F-34	Laminate Solenoid	34
2255-F-34	Laminate Solenoid	34
2256-F-34	Laminate Solenoid	34
2536-F-34	Laminate Solenoid	35
2537-F-34	Laminate Solenoid	35
2786-F-34	Laminate Solenoid	35
2787-F-34	Laminate Solenoid	36
3000-M-1	Laminate Solenoid	36
3001-M-1	Laminate Solenoid	36
3500-M-1	Laminate Solenoid	36
3501-M-1	Laminate Solenoid	36

ERMEC
www.ermec.com
ERMEC, S.L. BARCELONA
C/ Francesc Teixidó, 22
E-08918 Badalona
(Spain)

Tel.: (+34) 902 450 160
Fax: (+34) 902 433 088
info@ermec.com
www.ermec.com

ERMEC, S.L. MADRID
C/ Sagasta, 8, 1ª planta
E-28004 Madrid
(Spain)

PORTUGAL
portugal@ermec.com
BILBAO
bilbao@ermec.com



Terms and Conditions

1. Acceptance of Buyer's order is expressly made conditional on assent to the terms and conditions set forth herein and on attachment(s) hereto and they shall constitute the complete agreement between the parties. These terms and conditions may not be varied, or Buyer's order terminated in any manner, unless by a written agreement with legal consideration subsequently signed by an authorized official of Saia-Burgess Inc., or Saia-Burgess USA Inc. (also referred to herein as "Company"). Other representatives of the Company are not authorized to vary the conditions herein set forth. Failure to specifically dissent to these terms and conditions within a reasonable time or Buyer's acceptance of any goods covered by this acknowledgment shall constitute acceptance of said terms and conditions and they shall be controlling in every case.
2. Unless stated to the contrary on the face hereof, all goods furnished hereunder will be shipped F.O.B. point of shipment, and title in and the right of possession to such goods pass to the Buyer upon the Company's delivery to carrier at point of shipment.
3. Unless stated to the contrary on the face hereof, prices on the goods covered by this acknowledgment are firm for thirty (30) days from date of this acknowledgment. Any goods which the Buyer requires to be shipped subsequent to thirty (30) days from said date are subject to price changes made from date of acknowledgment to date of shipment.
4. Tooling, set-up, fitting-up, drawings, design information and partial preparation charges when invoiced cover only part of the cost thereof to the Company. The Buyer does not acquire any right, title or interest in any tooling, set-up, fitting-up, drawings, design information or invention resulting therefrom.
5. All partial preparation charges shall be due within thirty (30) days of first article approval. Acceptance/rejection of first article must be made immediately but in no event later than thirty days after date of first article shipment, and such acceptance/rejection shall be based solely on the parts meeting the specifications contained in the Company's drawing for said part. Failure of the Buyer to submit in writing a rejection of first article within thirty (30) days after shipment shall be an admission by Buyer and conclusive proof that such goods are accepted.
6. All shipping dates are tentative. The Company will not be responsible for delays or nonperformance, directly or indirectly, caused by governmental regulations or requirements, acts of God, unavailability of materials, work stoppages, slowdowns, boycotts, and other causes (whether or not similar in nature to any of these hereinbefore specified) beyond the Company's reasonable control.
7. This Company's extensive line of goods requires close coordination of the Buyer's requirements with the Company's production schedules to avoid possible delays in shipment. Accordingly, the Company reserves the right to ship approximately fourteen (14) days in advance of shipping date.
8. The Company warrants that the goods delivered hereunder shall be free from defects in material, workmanship and fabrication. The WARRANTY shall extend for a period of (a) one (1) year after date of delivery of such goods to Buyer or (b) that period specified otherwise on the front of this document (the greater of such periods (a) or (b) hereinbefore to be known as "Warranty Period"). THE COMPANY MAKES NO WARRANTY EXPRESS, IMPLIED, (INCLUDING BUT NOT LIMITED TO WARRANTIES OF MERCHANTABILITY AND FITNESS FOR INTENDED PURPOSE), OR STATUTORY, OTHER THAN THE FOREGOING EXPRESS WARRANTY. Failure of Buyer to submit any claim hereunder within the Warranty Period after receipt of such goods shall be an admission by Buyer and conclusive proof that such articles are in every respect as warranted and shall release the Company from any and all claims for damage or loss sustained by Buyer. In the event Buyer submits a claim for breach of warranty within the required Warranty Period, the parties agree that Buyer's sole and exclusive remedy shall be the repair or replacement of such defective goods or a refund of the price of the defective goods. In no event shall the Company be liable for incidental or consequential damages or special, indirect or incidental damages arising out of, or as the result of, the sale, delivery, non-delivery, use of loss of use of goods or any part thereof, even though the Company has been negligent. This warranty is not intended to cover consumer products as defined in the Magnuson-Moss Warranty-Federal Trade Commission Improvement Act 15 U.S.C. Sections 2501-12. Goods delivered hereunder are not designed, intended, or authorized for use as components in systems intended for surgical implant into the body, or other applications intended to support or sustain life, or for any other application in which the failure of the Company product could create a situation where personal injury or death may occur. Should Buyer purchase or use Company goods for any such unintended or authorized application, Buyer shall indemnify and hold Company and its officers, employees, subsidiaries, agents, and affiliates harmless against all claims, costs, damages, and expenses, and reasonable attorney fees arising out of, directly or indirectly, any claim of personal injury or death associated with such unintended or unauthorized use, even if such claim alleges that Company was negligent regarding the design or manufacture of the goods. Any lawsuit or other action based upon breach of this contract or upon any other claim arising out of this sale (other than an action by the Company for any amount due to Company by Buyer) must be commenced within one (1) year from the date of the tender or delivery by the Company.
9. The Company agrees to indemnify and save Buyer harmless from third party claims by reason of known infringement of any patent, trademark or copyright relating to goods furnished hereunder.
10. Orders accepted by the Company cannot be countermanded or shipments deferred or goods returned except with authorization from the Company and the Company accepts no responsibility for goods returned without such authorization. When return of material is authorized by the Company, shipping charges on said returned material are to be prepaid F.O.B. Destination unless otherwise noted by the Company in its authorization to return. The Company shall not issue credit on any product which has been altered or defected in any way or upon which additional operations have been performed.
11. Contracts or orders are not subject to cancellation, change, reduction in amount, or suspension of deliveries except with the Company's consent and upon terms which indemnify it against loss; in the event Buyer cancels any order or portion thereof or fails to meet any obligation hereunder causing cancellation or rescheduling of any order or portion thereof or requests a rescheduling of scheduled shipments and such request is accepted by the Company, Buyer agrees to pay, at the Company's option, cancellation or reschedule charges as follows:
 - a. Any and all partial preparation charges then due or which may become due.
 - b. Sixty (60) to ninety (90) days prior to scheduled delivery, Buyer pays for all unique component parts at fair market value.
 - c. Forty-five (45) to sixty (60) days prior to scheduled delivery, Buyer pays for all unique component parts and work in process at fair market value.
 - d. Zero (0) to forty-five (45) days prior to scheduled delivery, Buyer cannot cancel or reschedule and will be shipped and billed to prior scheduled delivery.

In the event that the Buyer does not accept shipment on the total purchase quantity within twelve (12) months after receipt by the Company of Buyer's order, the Company reserves the right to:

 - a. Adjust unit price applicable to this shipped quantity and to bill the Buyer for the accumulated differences.
 - b. Charge cancellation or rescheduling fees.
12. Factory service by personnel from the United States for loaned or purchased items, if required, is available at a charge. Contact the Company for applicable fees. Spare and replacement parts for the goods, can be purchased from the Company.
13. The Company shall have the right to suspend or cancel this agreement at any time upon Buyer making an assignment for the benefit of creditors; or becoming bankrupt or insolvent; or upon a petition being filed in a court of competent jurisdiction proposing the appointment of a receiver; or in the event that the Buyer be adjudicated bankrupt or insolvent or reorganized under the provisions of any applicable bankruptcy or insolvency act.
14. The Company represents that with respect to the production of the goods and/or the performance of the services stated herein, it has fully complied with all the applicable provisions of the Fair Labor Standards Act of 1938, as amended, including Sections 6, 7 and 12, regulations under section 14, and all other applicable administrative Regulations.
15. In connection with performance of work hereunder, the Company agrees to comply with all provisions, including specifically paragraphs (1) through (7), of Sec. 202, of Executive Order No. 11246 of September 12, 1965 as amended, and rules, regulations and orders pertaining thereto.
16. In addition to the rights and remedies reserved herein, the Company shall have all rights and remedies conferred by law and shall not be required to proceed with performance of the contract arising herefrom, if Buyer is in default to the Company under this or any other contract.
17. The Company disclaims any liability for damages for delays in delivery or non-delivery of goods ordered caused in whole or in part by shortages or unavailability of energy and/or materials or supplies unless other arrangements in writing have been made with the Company covering the goods ordered.
18. Unless specifically noted hereon, qualification tests and any test data are not included in the selling price. Qualification tests may be performed by the Company and test data supplied at the specific request and expense of the Buyer.
19. Unless otherwise specifically noted on the front of this document, payment terms are Net 30 Days. All payments received beyond the stipulated payment terms will incur interest at the rate of 1.5% per month. If Company shall at any time doubt Buyer's financial responsibility, Company may demand adequate assurance of due performance or decline to make any further shipments except upon receipt of cash payment in advance or security. If Company demands adequate assurance of due performance and the same is not forthcoming within ten (10) days after the date of Company's demand, Company may, at its option, (i) continue to defer further shipments under this order and/or any other order from Buyer which has been accepted by Company until adequate assurance is received, or (ii) cancel this order and/or other orders from Buyer which have been accepted by Company and recover damages. If Buyer fails in any way to fulfill the terms and conditions herein, Company may defer further shipments until such default is corrected or cancel this order and recover damages. Company shall have a security interest in, and lien upon, any property of Buyer in Company's possession as security for the payment of any amounts owing to Company by Buyer.
20. Neither party may assign any of its rights or obligations hereunder without the prior written consent of the other except that Company shall have the right to assign to any company with which it is affiliated or to any corporation into which it shall be merged, with which it shall be consolidated, or by which it, or all or substantially all of its assets, shall be acquired.
21. In the event that any portion hereof shall violate any applicable statute, ordinance, or rule of law, such provision shall be ineffective to the extent of such violation without invalidating any other provision hereof. This document and the sale of all goods shall be governed by and construed in accordance with the laws of the State of Virginia.
22. The products produced by The Company are typically designed by The Company. As such, the Company reserves the right to make design changes and to authorize concessions for all catalog and standard designs without customer notification. Customer approval will be sought on other special, customer-specific designs when the change or concessions affects a form, fit or function characteristic. When a customer contract provides for customer control of the design but also allows the sub-contractor to request MRB authority from the customer, this statement is to be considered as a formal request for such authority.
23. Ledex® and Dormeyer® catalog solenoid products produced after April 1, 2006 are RoHS compliant. Requests for customer special RoHS designs are handled on a case-by-case basis. If an existing solenoid design must undergo a change process to become RoHS compliant, and if this results in obsolete inventory, the customer will be charged for this obsolescence. Most Saia-Burgess switch and motor products are also RoHS compliant but customers need to verify specific part numbers with Saia-Burgess Inc.
24. Saia-Burgess reserves the right to pass raw material and / or energy surcharges on to customers in times of unusual escalation in these material / energy costs.

Headquarters

Johnson Electric Holdings Limited
Johnson Building, 6-22 Dai Shun St, Tai Po Industrial
Estate, New Territories

Hong Kong

Tel: +852 2663 6688

Fax: +852 2897 2054

e-mail: salessupport@johnsonelectric.com

Sales Offices

Asia

Shanghai, China

12/F, Hua Rong Tower
1289 Pudong Road South

Shanghai

200122 China

T +86 21 5882 2880

F +86 21 5882 2800

Tokyo, Japan

Keihin Higashi-Ohi Bldg.
10/F, 2-13-8 Higashi-Ohi
Shinagawa-ku

Tokyo 140-0011 Japan

T +81 3 5762 1031

F +81 3 5762 1032

Seoul, Korea

Misung Bldg B127, 115-7
Nonhyun-Dong, Kangnam-Gu,

Seoul, Korea 135-010

T +82 2 518 8347/8341

F +82 2 518 8342

Singapore

50 Raffles Place #24-02,
Singapore Land Tower

Singapore 048623

T +65 6224 7570

F +65 6224 4538

Europe

Austria

Slovenia, Slovakia, Hungary,

Czech Republic

Linzer Bundesstrasse 101

A-5023 **Salzburg**

T +43 662 88 4910

F +43 662 88 4910 11

France

10 Bld. Louise Michel

F-92230 **Gennevilliers**

T +33 1 46 88 07 70

F +33 1 46 88 07 99

78 Boulevard du 11 Novembre

69003 **Villeurbanne**

T +33 4 37 48 84 60

F +33 4 72 43 90 11

Germany

Sweden, Denmark,

Norway, Finland

Weissenpferd 9

D-58553 **Halver**

T +49 2353 911 0

F +49 2353 911 230

Italy

Via Cadamosto 3

I-20094 Corsico, **Milano**

T +39 02 4869 21

F +39 02 4860 0692

1, Via Vittime di Piazza Fontana

I-10024 **Moncalieri**

T +39 011 68 05 401

F +39 011 68 05 411

Switzerland

Poland, Spain, Turkey, Portugal

Bahnhofstrasse 18

CH-3280 **Murten**

T +41 26 672 71 11

F +41 26 670 19 83

The Netherlands/Belgium

Hanzeweg 12c

NL-2803 **MC Gouda**

T +31 1825 43 154

F +31 1825 43 151

United Kingdom/Ireland

Dukesway

Team Valley Trading Estate

Gateshead

Tyne & Wear NE11 0UB

United Kingdom

T +44 191 401 61 00

F +44 191 401 63 05

Americas

Connecticut

10 Progress Drive, **Shelton,**
CT 06484, USA

T +1 203 447 5362

F +1 203 447 5383

Illinois

3115 N. Wilke Road - Suite C

Arlington Heights,

IL 60004

T +1 847 368 2146

F +1 847 368 2152

Ohio

801 Scholz Drive

Vandalia, OH 45377

T +1 937 454 2345

F +1 937 898 8624

Ontario, Canada

70 Ironside Crescent Unit 7

Scarborough, **Ontario**

M1X 1G4 Canada

T +1 416 299 0852

F +1 416 299 6756

Sao Paulo, Brazil

Av. Papa Joao Paulo I - 1256

CEP 07170-350

Guarulhos **Sao Paulo, Brazil**

T (55) 11-643 156 00

F (55) 11-643 247 11



ERMEC, S.L. BARCELONA

C/ Francesc Teixidó, 22

E-08918 Badalona

(Spain)

Tel.: (+34) 902 450 160

Fax: (+34) 902 433 088

info@ermec.com

www.ermec.com

ERMEC, S.L. MADRID

C/ Sagasta, 8, 1ª planta

E-28004 Madrid

(Spain)

PORTUGAL

portugal@ermec.com

BILBAO

bilbao@ermec.com



www.ermec.com

Johnson Electric Group

Johnson Building, 6-22 Dai Shun Street
Tai Po Industrial Estate, N.T., Hong Kong
Tel: (852) 2663 6688
Fax: (852) 2663 6110
Web Site: www.johnsonelectric.com



ERMEC, S.L. BARCELONA
C/ Francesc Teixidó, 22
E-08918 Badalona
(Spain)

Tel.: (+34) 902 450 160
Fax: (+34) 902 433 088
info@ermec.com
www.ermec.com

ERMEC, S.L. MADRID
C/ Sagasta, 8, 1ª planta
E-28004 Madrid
(Spain)

PORTUGAL
portugal@ermec.com
BILBAO
bilbao@ermec.com

