



Distribución de componentes
eléctricos y electrónicos

Tel.: (+34) 902 450 160

Fax: (+34) 902 433 088

ermec@ermec.com

www.ermec.com

DC brushless catalogue 2009



PARVALUX®



www.parvalux.com





ermei

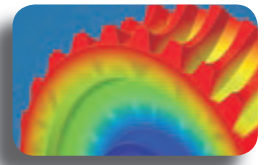

our technology

Our motor technologies span from AC induction through to DC brushless and our gearbox know-how covers practically all types – from spur/helical through to worm and planetary.

Motor types:

- » AC induction
- » AC/DC series
- » DC shunt
- » DC permanent magnet
- » DC brushless

Gearbox types:

- » Worm and wheel
- » Double-reduction
- » Multi-spur
- » In-line multi-spur
- » Planetary

Over the years technological innovations and contemporary manufacturing methodologies, such as lean enterprise and six sigma, have changed the way we produce our products; but at the heart of our business we have preserved a solid ethos to provide high quality, reliable products at globally competitive prices.

Our reliability is founded upon sixty years of success. Today, with an installed base of over five million, customers all over the world rely on Parvalux products to keep their products and their businesses performing.

We have also built an enviable reputation for providing bespoke designed geared motors that meet our customers exacting needs. Our capacity to provide customised units in small or vast quantities, at globally competitive prices is, we believe, unmatched.

We continue to grow by focusing on the values that mean the same today as they did sixty years ago: choice, reliability, customisation.



our facility

There are an increasing number of Original Equipment Manufacturers (OEM's) who need a bespoke geared motor solution.

It is for this reason that Parvalux have invested heavily in the technology and the people required to design and develop products that meet the demands of the individual customer.

By utilising 3D-modelling and Finite Element Analysis (FEA) we are able to produce prototypes at our UK facility quickly and efficiently.

Our lean manufacturing capability then enables us to rapidly convert the prototype into a cost-effective solution that fulfils budget and performance needs perfectly.

Our aim is to ensure that we serve the widest possible range of applications within the low-powered geared motor market.

Our extensive range enables customers to choose from an almost infinite number of gear combinations to meet the output speed and torque requirements of their desired application.

Our key strength is our ability to customise our products with a whole host of extras; such as custom built flanges and shafts, tailored windings, mechanical cams and switches – as well as customised wiring and connections.

We provide single, double or hollow shaft as standard. In addition, we can provide custom mounting kits to interface the Parvalux gearbox with your existing mounting.

To ensure the overall cost remains competitive we apply lean manufacturing techniques at our production facilities and manage a quality-driven global supply chain.

our team

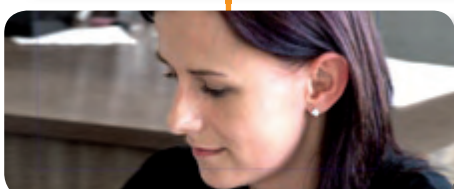

If there is one definable difference in Parvalux, it is our people. Our ability to develop, produce and market innovative geared motor solutions is totally dependant on our team.

Recent months have seen a significant recruitment drive to hire world-class engineers, marketers and designers to help build the future Parvalux.

These newcomers bring not only a wealth of experience from within our industry; they have immediately raised our ability to innovate and improve almost every aspect of business.

This has already delivered a quantum leap in our performance in 2008 and will continue to do so over the next decade.

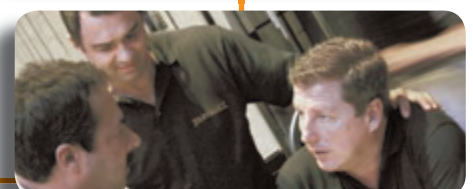
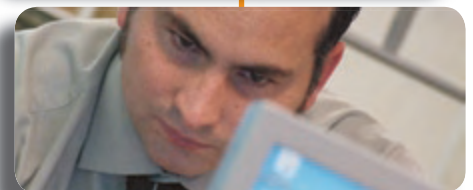

contents

engineering
reliability into
every product
for over sixty
years

Founded in 1947, as one of the UK's first manufacturers of small geared motors, Parvalux has built a tremendous reputation for offering one of the worlds most extensive and reliable ranges of customisable AC and DC geared motor units. Today, Parvalux continues to be a successful, privately-owned and run British business with distributors in 22 countries.

Motor data	
PBL42	4
PBL42IE	6
PBL60	8
PBL60IE	10
PBL86	12
Controller data	
S controller	14
N and B controllers	15
50B controller	17
Customisation options	18
Selection guide	19
Geared motors	
worm gearboxes	20
in-line worm gearboxes	39
worm spur gearboxes	46
Flange options	57
Spring applied brakes	59
Encoder	60
Shaft and worm gearbox positions	61
Gearbox information	62
Mechanical data	63
Gearbox thermal rating limits	64
EMC Directive compliance	65
CE directive	66
IP protection	67
Contacts	68



E&OE (errors and omissions excepted); in line with our policy of continuous improvement all data is subject to change.
All drawings and product representations enclosed herein are not to scale.



geared motors



legendary reliability



totally customisable

PBL42 motor data

FRAME SIZE	42mm square in 4 different lengths
TYPE	DC brushless motor
TORQUE	0.0625 - 0.2 Nm continuous
MAX SPEED	4000 rpm
VOLTAGE	24V DC
CONNECTION	Flying leads 30cm flexible; terminated in single 8-way in-line pluggable terminal block connector
CONTROLLER	Available with or without controller
SHAFT	Double or single ended on request
INSULATION CLASS	F
IP PROTECTION	IP54 (IP50 at exposed motor shafts)
OPTIONS	See page 18

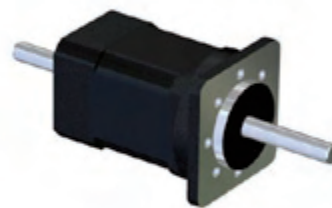

PBL42-67 pictured with Parvalux standard flange

Motor		PBL42-47	PBL42-67	PBL42-87	PBL42-107
Max rated speed	rpm	4000	4000	4000	4000
Rated torque	Nm	0.0625	0.125	0.17	0.2
Rated power at max rated speed	W	26	52	71	84
Peak torque	Nm	0.188	0.375	0.555	0.75
DC bus voltage nominal	V	24	24	24	24
Back EMF	V/krpm	4	4	4	4
Torque constant	Nm/A	0.047	0.047	0.047	0.047
Rated current	A rms	1.3	2.7	3.6	4.3
Current for peak torque	A rms	4.4	8.9	13	18
Stator resistance (25 °C)	ohms	1.7	0.85	0.5	0.36
Number of poles		8	8	8	8
Dimension 'A'	mm	47	67	87	107
Inertia	gcm ²	32	56	80	104
Weight	kg	0.39	0.56	0.73	0.9
Connector size - pin pitch	mm	3.5	3.5	5.08	5.08

- Motor speed is variable up to 4000 rpm, however maximum speed is reduced if DC bus voltage is below the nominal value.
- Standard motor feedback is by open collector Hall effect sensors.
- Available with double ended shafts to support a range of optional accessories.
- Alternative mechanical interfaces available.

Torque/speed characteristics

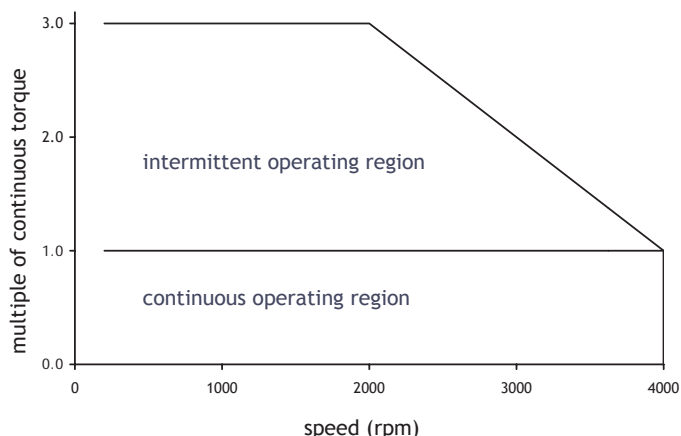

Connector wiring

Pin	Description	Wire		
		colour	type	size
1	Motor phase U	YEL	UL1332	AWG18
2	Motor phase V	RED	UL1332	AWG18
3	Motor phase W	BLK	UL1332	AWG18
4	Hall sensor 0V	BLK	UL1332	AWG22
5	Hall sensor U	BLU	UL1332	AWG22
6	Hall sensor V	GRN	UL1332	AWG22
7	Hall sensor W	WHT	UL1332	AWG22
8	Hall sensor supply	RED	UL1332	AWG22

Motor commutation

For clockwise rotation, motor phases are powered according to the table. For anticlockwise rotation, HIGH and LOW phases are interchanged.

Hall sensor outputs			Motor phases powered		
Hall U	Hall V	Hall W	Phase U	Phase V	Phase W
1	0	0	HIGH	X	LOW
1	1	0	X	HIGH	LOW
0	1	0	LOW	HIGH	X
0	1	1	LOW	X	HIGH
0	0	1	X	LOW	HIGH
1	0	1	HIGH	LOW	X

Parvalux standard flange/mount and shaft

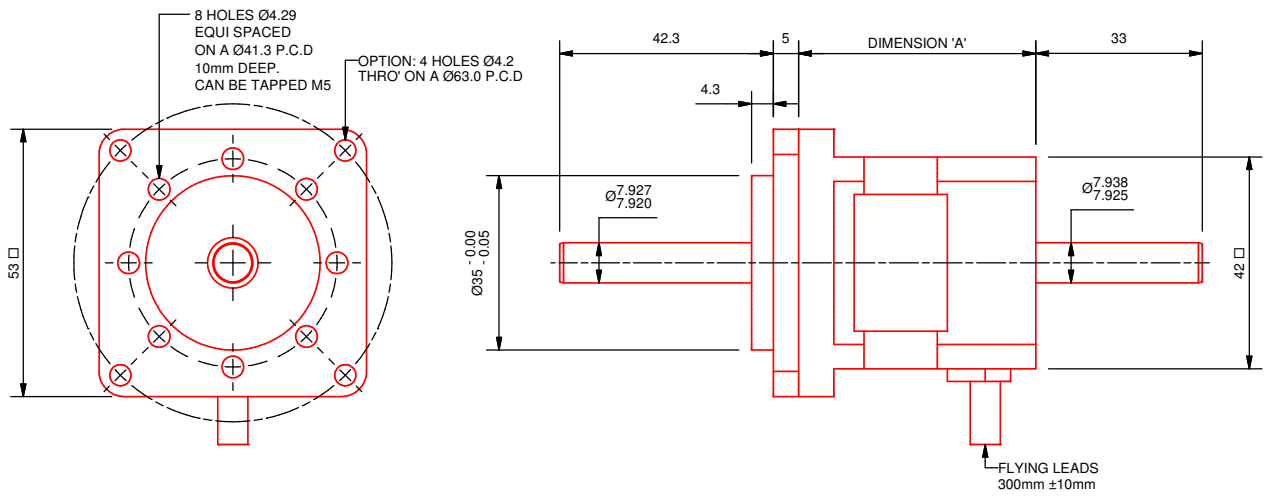

PBL42 motor and controller packages

Motor		PBL42-47	PBL42-67	PBL42-87	PBL42-107
Controller		S	S	N	B
Max rated speed	rpm	4000	4000	4000	4000
Rated torque	Nm	0.0625	0.125	0.17	0.2
15 minute rating	Nm	0.078	0.16	0.23	0.31
Peak torque (duration 6 seconds)	Nm	0.125	0.25	0.37	0.5
DC bus voltage nominal	V	24	24	24	24
DC bus voltage min-max	V	16-32	16-32	16-32	16-32
DC bus current at no load and max rated speed	A	0.2	0.27	0.34	0.42
DC bus current at rated torque and max rated speed	A	1.8	3.3	4.3	5
Controller cont. current	A	2.5	5	7.5	10
Controller peak current	A	5	10	15	20

Torque/speed characteristics

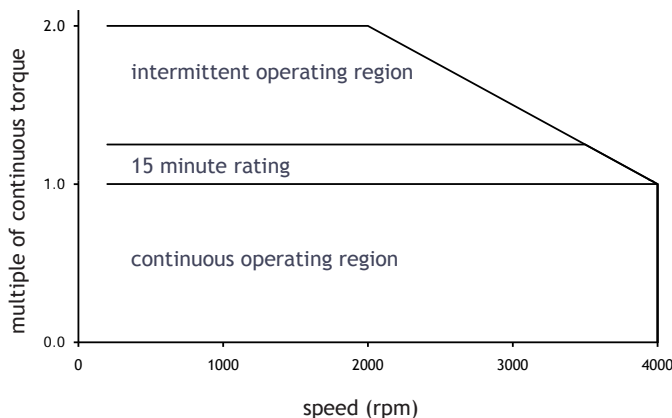

- The controllers we supply are matched for each motor in the range and tested as a pair with the motors during production.
- They operate from a 24V supply and have an analogue input for motor speed, an input for forward/reverse direction and a pulsed output to indicate motor speed.
- Most models have an additional input for enable/disable and an output indicating a fault condition.

PBL42IE motor data

FRAME SIZE	42 mm square in 3 different lengths
TYPE	Brushless DC motor with integral controller
TORQUE	0.125 - 0.2 Nm
MAX SPEED	4000 rpm
VOLTAGE	24V DC
CONNECTION	Single 7-way in-line pluggable terminal block
CONTROLLER	Integral 2-quadrant controller, functionally identical to S controller (See page 14)
SHAFT	Single ended
INSULATION CLASS	F
IP PROTECTION	IP54 (IP50 at exposed motor shaft and connector)
OPTIONS	See page 18

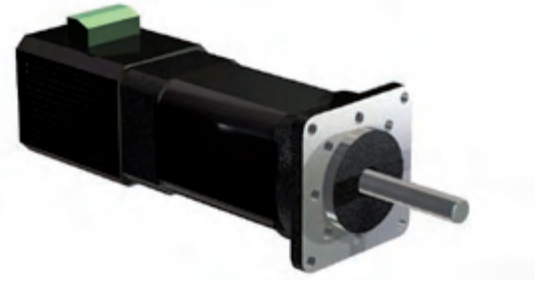

PBL42-87IE pictured

Motor type		PBL42-67IE	PBL42-87IE	PBL42-107IE
Max rated speed	rpm	4000	4000	4000
Rated torque	Nm	0.125	0.17	0.2
Rated power at max speed	W	52	71	84
15 minute rating	Nm	0.16	0.23	0.31
Peak torque (duration 6 seconds)	Nm	0.25	0.37	0.5
DC bus voltage nominal	V	24	24	24
DC bus voltage min-max	V	16-32	16-32	16-32
DC bus current at no load and max rated speed	A	0.27	0.34	0.42
DC bus current at rated torque and max rated speed	A	3.3	4.3	5
Dimension 'A'	mm	67	87	107
Dimension 'B'	mm	44	56	56
Inertia	gcm ²	56	80	104
Weight	kg	0.66	0.85	1
Connector size - pin pitch	mm	3.5	3.5	3.5

- Motor speed is variable up to 4000 rpm, however maximum speed is reduced if DC bus voltage is below the nominal value.
- Standard motor feedback is by open collector Hall effect sensors.
- Recommended maximum ambient temperature for integral controller is 30°C. Above this temperature, the rating will be reduced.
- Alternative mechanical interfaces available.

Torque/speed characteristics

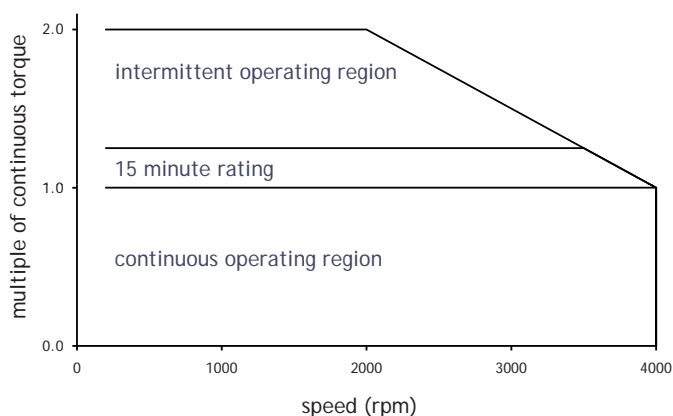

Connector wiring

Pin	Label	Description
1	Vp+	Supply +V
2	Vp-	Supply 0V
3	GND	0V output for control circuits
4	PG	Pulse output
5	SV	Speed input
6	F/R	Reverse input
7	+5V	Supply output for control circuits

A potentiometer or analogue voltage connected to the SV input will be required to obtain the constant speed specified on the order and name plate. A 4.7 k potentiometer is supplied.

PBL42IE with standard flange/mount and shaft

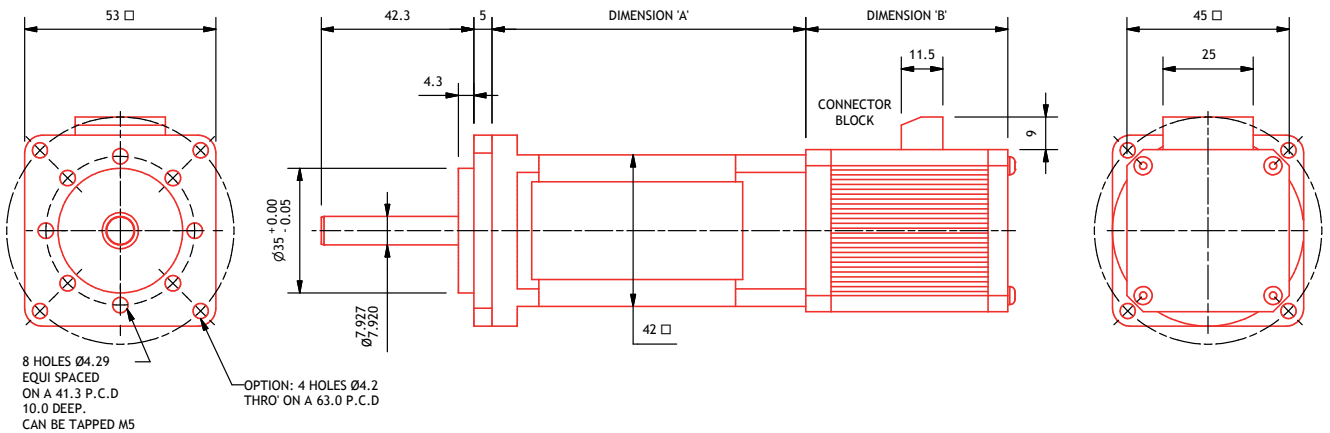

HP planetary

We are very proud to present our new line of high quality HP planetary gearheads, designed and manufactured in the UK by our skilled team of engineers.

The 1-4 stage gearboxes, available in three frame sizes, offer customers an unrivalled choice of gear ratios, an unbeatable range of input and output flange options and Parvalux reliability at an incredible price. They are also the first ever Parvalux gearboxes available with a servo-coupling to interface with any motor, and come with a polished chrome finish as standard.

The range has been designed to operate marginally below that of servo specifications, allowing us to offer a cutting edge design for a fraction of the cost of a specialised servo application gearhead. See page 11 for more details.



construction details

- high tensile alloy steel cap-head screws
- high capacity ball bearings, capable of high radial loads; twin contact seals ensure gearbox sealing integrity
- planet gears, 98% efficient, manufactured from high grade alloy steel; heat treated in a vacuum to provide low distortion combined with high bending strength and low-wear characteristics
- pins heat treated to 60+ HRC and precision centreless ground; oversized to provide high rigidity and high side loading capacity for planet gears
- Nitrile rubber seal and o-rings providing dynamic sealing of gearbox lubricant
- annulus gear manufactured in high strength low alloy steel (HSLA) for a medium-high bending strength; with polished chrome exterior finish as standard; optimised involute form

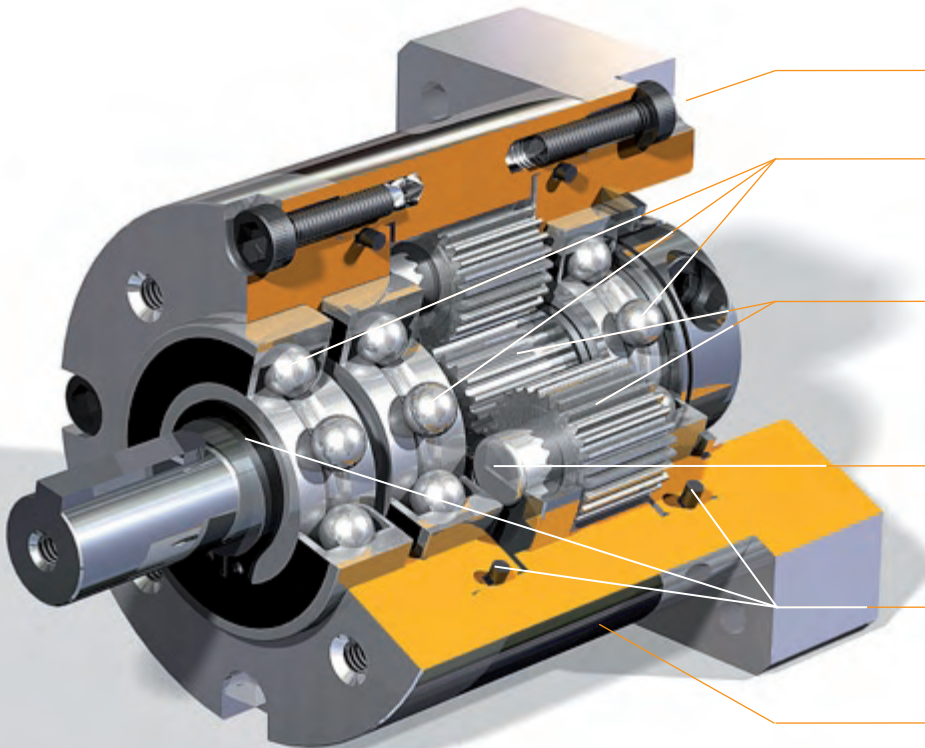

PBL60 motor data

FRAME SIZE	60 mm square in 4 different lengths
TYPE	Brushless DC motor
TORQUE	0.11 - 0.44 Nm
MAX SPEED	4000 rpm
VOLTAGE	24V DC
CONNECTION	Flying leads 30cm flexible; terminated in single 8-way in-line pluggable terminal block connector
CONTROLLER	Available with or without controller
SHAFT	Double or single ended on request
INSULATION CLASS	F
IP PROTECTION	IP54 (IP50 at exposed motor shafts)
OPTIONS	See page 18

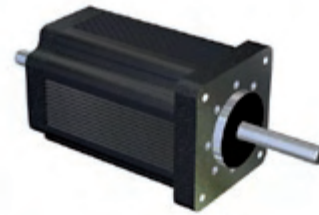

PBL60-98 pictured with Parvalux standard flange

Motor		PBL60-78	PBL60-98	PBL60-118	PBL60-138
Max rated speed	rpm	4000	4000	4000	4000
Rated torque	Nm	0.11	0.22	0.32	0.44
Rated power at max rated speed	W	46	92	134	184
Peak torque	Nm	0.33	0.66	0.96	1.32
DC bus voltage nominal	V	24	24	24	24
Back EMF	V/krpm	4.3	4.3	4.3	4.3
Torque constant	Nm/A	0.05	0.05	0.05	0.05
Rated current	A rms	2.2	4.4	6.4	8.8
Current for peak torque	A rms	7.3	15	21	29
Stator resistance (25 °C)	ohms	0.87	0.32	0.23	0.2
Number of poles		4	4	4	4
Dimension 'A'	mm	75	95	115	135
Inertia	gcm ²	71	119	169	215
Weight	kg	0.7	1	1.3	1.6
Connector size - pin pitch	mm	5.08	5.08	5.08	5.08

- Motor speed is variable up to 4000 rpm, however maximum speed is reduced if DC bus voltage is below the nominal value.
- Standard motor feedback is by open collector Hall effect sensors.
- Available with double ended shafts to support a range of optional accessories.
- Alternative mechanical interfaces available.

Torque/speed characteristics

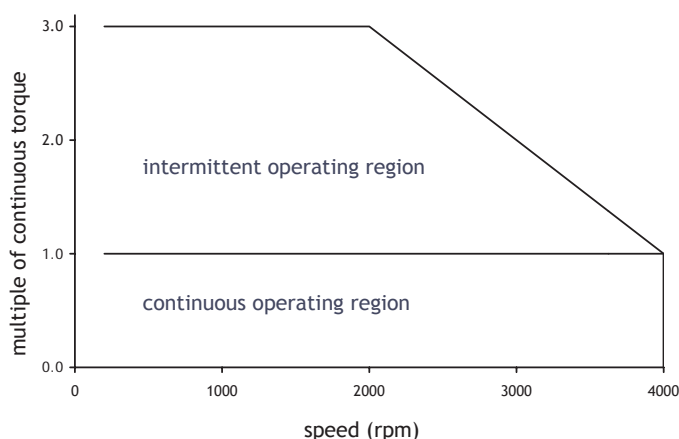

Connector wiring

Pin	Description	Wire		
		colour	type	size
1	Motor phase U	YEL	UL1332	AWG18
2	Motor phase V	RED	UL1332	AWG18
3	Motor phase W	BLK	UL1332	AWG18
4	Hall sensor 0V	BLK	UL1332	AWG22
5	Hall sensor U	BLU	UL1332	AWG22
6	Hall sensor V	GRN	UL1332	AWG22
7	Hall sensor W	WHT	UL1332	AWG22
8	Hall sensor supply	RED	UL1332	AWG22

Motor commutation

For clockwise rotation, motor phases are powered according to the table. For anticlockwise rotation, HIGH and LOW phases are interchanged.

Hall sensor outputs			Motor phases powered		
Hall U	Hall V	Hall W	Phase U	Phase V	Phase W
1	0	0	HIGH	X	LOW
1	1	0	X	HIGH	LOW
0	1	0	LOW	HIGH	X
0	1	1	LOW	X	HIGH
0	0	1	X	LOW	HIGH
1	0	1	HIGH	LOW	X

Parvalux standard flange/mount and shaft

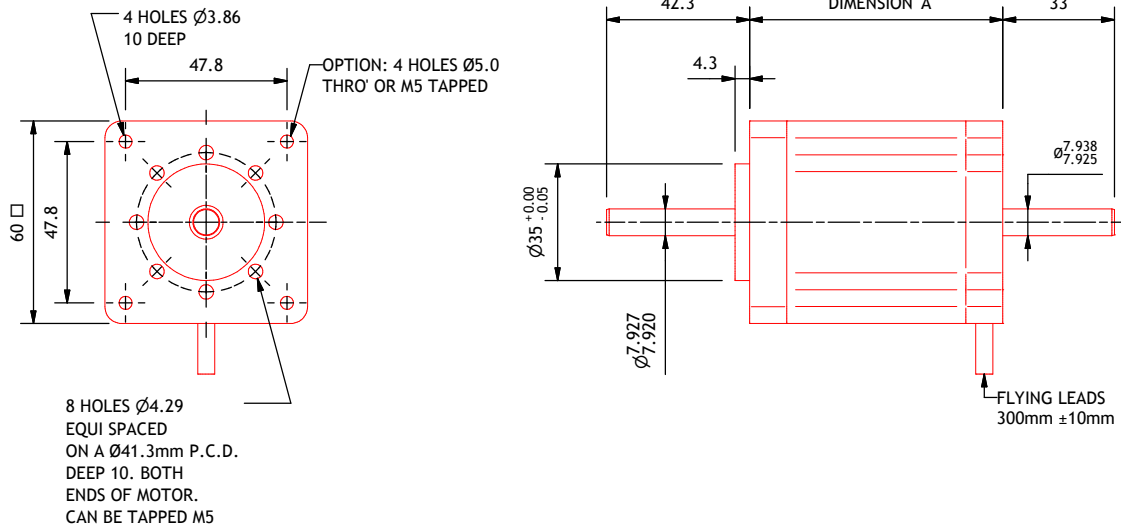

PBL60 motor and controller packages

Motor		PBL60-78	PBL60-98	PBL60-118	PBL60-138
Controller ref.		N	N	B	B
Max rated speed	rpm	4000	4000	4000	4000
Rated torque	Nm	0.11	0.22	0.32	0.44
15 minute rating	Nm	0.14	0.28	0.4	0.55
Peak torque (duration 6 seconds)	Nm	0.22	0.44	0.64	0.88
DC bus voltage nominal	V	24	24	24	24
DC bus voltage min-max	V	16-32	16-32	16-32	16-32
DC bus current at no load and max rated speed	A	0.25	0.38	0.5	0.65
DC bus current at rated torque and max rated speed	A	3	5.5	7.5	10
Controller cont. current	A	5	7.5	10	15
Controller peak current	A	10	15	20	30

Torque/speed characteristics

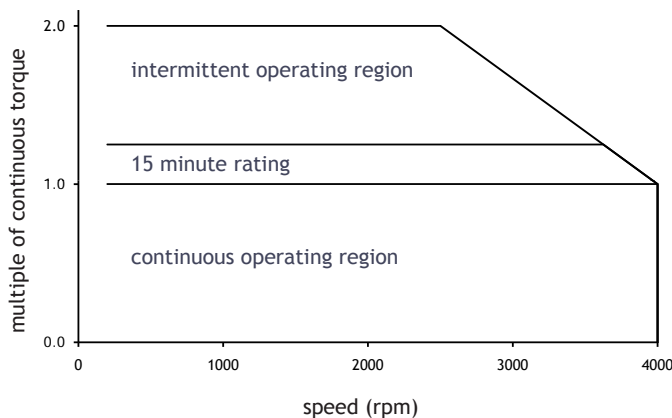

- The controllers we supply are matched for each motor in the range and tested as a pair with the motors during production.
- They operate from a 24V supply and have an analogue input for motor speed, an input for forward/reverse direction and a pulsed output to indicate motor speed.
- Most models have an additional input for enable/disable and an output indicating a fault condition.

PBL60IE motor data

FRAME SIZE	60 mm square in 3 different lengths
TYPE	Brushless DC motor with integral controller
TORQUE	0.22 - 0.44 Nm
MAX SPEED	4000 rpm
VOLTAGE	24V DC, 48V DC
CONNECTION	Single 7-way in-line pluggable terminal block
CONTROLLER	Integral 2-quadrant controller, functionally identical to S controller (See page 14)
SHAFT	Single ended
INSULATION CLASS	F
IP PROTECTION	IP54 (IP50 at exposed motor shaft and connector)
OPTIONS	See page 18

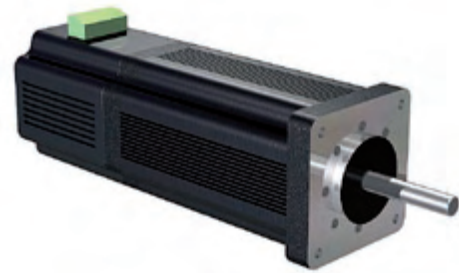

PBL60-118IE pictured

Motor type		PBL60-98IE	PBL60-118IE	PBL60-138IE
Max rated speed	rpm	4000	4000	4000
Rated torque	Nm	0.22	0.32	0.44
Rated power at max speed	W	92	134	184
15 minute rating	Nm	0.28	0.4	0.55
Peak torque (duration 6 seconds)	Nm	0.44	0.64	0.88
DC bus voltage nominal	V	24	24	48
DC bus voltage min-max	V	16-32	16-32	20-58
DC bus current at no load and max rated speed	A	0.38	0.5	0.32
DC bus current at rated torque and max rated speed	A	5.5	7.5	5
Dimension 'A'	mm	95	115	135
Dimension 'B'	mm	61	61	61
Inertia	gcm ²	119	169	215
Weight	kg	1.2	1.5	1.8
Connector size - pin pitch	mm	3.5	3.5	3.5

- Motor speed is variable up to 4000 rpm, however maximum speed is reduced if DC bus voltage is below the nominal value.
- PBL60-138IE will operate from 24V supply with a rated speed of 2000rpm.
- Standard motor feedback is by open collector Hall effect sensors.
- Recommended maximum ambient temperature for integral controller is 30°C. Above this temperature, the rating will be reduced.
- Alternative mechanical interfaces available.

Torque/speed characteristics

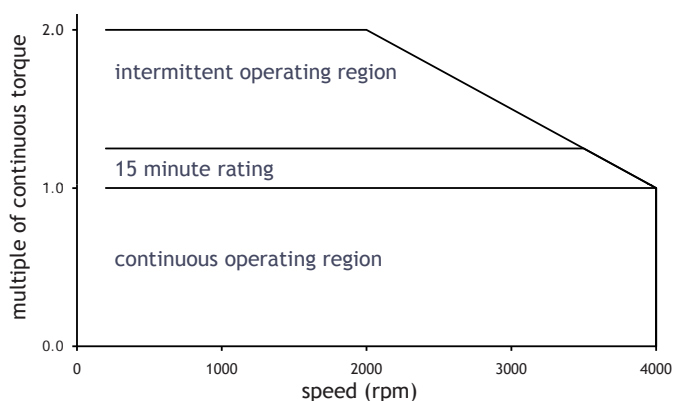

Connector wiring

Pin	Label	Description
1	Vp+	Supply +V
2	Vp-	Supply 0V
3	GND	0V output for control circuits
4	PG	Pulse output
5	SV	Speed input
6	F/R	Reverse input
7	+5V	Supply output for control circuits

A potentiometer or analogue voltage connected to the SV input will be required to obtain the constant speed specified on the order and name plate. A 4.7 k potentiometer is supplied.

General tolerance on data is +/- 10%; Values shown are at normal operating temperature unless stated.

PBL86 motor data

FRAME SIZE	86 mm square in 3 lengths
TYPE	Brushless DC motor
TORQUE	0.7 - 1.4 Nm
MAX SPEED	4000 rpm
VOLTAGE	24V, 48V DC
CONNECTION	Flying leads 30cm flexible; terminated in single 8-way or 5-way (Hall sensors only) in-line pluggable terminal block connector
CONTROLLER	Available with or without controller
SHAFT	Double or single ended on request
INSULATION CLASS	F
IP PROTECTION	IP54 (IP50 at exposed motor shafts)
OPTIONS	See page 18

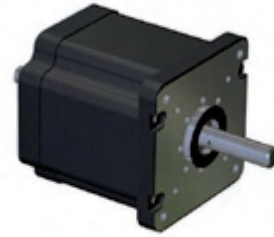

PBL86 pictured with Parvalux standard flange

Motor		PBL86-91	PBL86-91	PBL86-118	PBL86-145
Rated speed	rpm	3000	3000	3000	3000
Max speed	rpm	4000	4000	4000	4000
Rated torque	Nm	0.7	0.7	1.1	1.4
Rated power	W	220	220	346	440
Peak torque	Nm	2.1	2.1	3.3	4.2
DC bus voltage nominal	V	24	48	48	48
Back EMF	V/krpm	5.5	9.5	9.5	9.5
Torque constant	Nm/A	0.065	0.11	0.11	0.11
Rated current	A rms	12	7	11	14
Current for peak torque	A rms	40	23	37	47
Stator resistance (25 °C)	ohms	0.08	0.22	0.08	0.06
Number of poles		8	8	8	8
Dimension 'A'	mm	91	91	118	145
Inertia	gcm ²	1100	1100	2100	3100
Weight	kg	2.2	2.2	3.2	4.2
Connector size - no of pins		5	8	5	5
Connector size - pin pitch	mm	3.5	5.08	3.5	3.5

- Motor speed is variable up to 4000 rpm, however maximum speed is reduced if DC bus voltage is below the nominal value.
- Standard motor feedback is by open collector Hall effect sensors.
- Available with double ended shafts to support a range of optional accessories.
- Alternative mechanical interfaces available.

Torque/speed characteristics

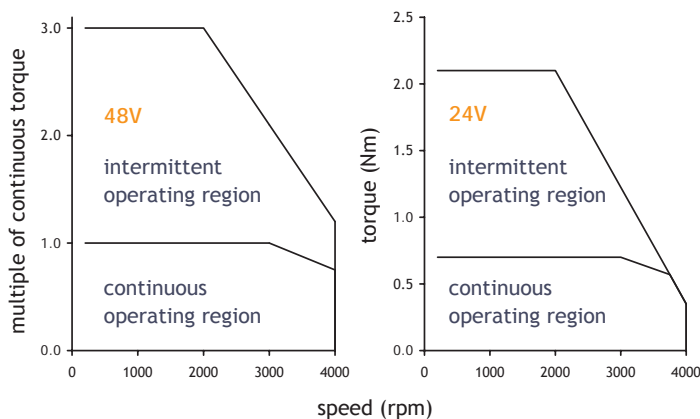

Connector wiring

Pin		Description	Wire		
8-pin connector	5-pin connector		colour	type	size
1	-	Motor phase U	YEL	UL1332	AWG16
2	-	Motor phase V	RED	UL1332	AWG16
3	-	Motor phase W	BLK	UL1332	AWG16
4	1	Hall sensor 0V	BLK	UL1332	AWG22
5	2	Hall sensor U	BLU	UL1332	AWG22
6	3	Hall sensor V	GRN	UL1332	AWG22
7	4	Hall sensor W	WHT	UL1332	AWG22
8	5	Hall sensor supply	RED	UL1332	AWG22

Motor commutation

For clockwise rotation, motor phases are powered according to the table. For anticlockwise rotation, HIGH and LOW phases are interchanged.

Hall sensor outputs			Motor phases powered		
Hall U	Hall V	Hall W	Phase U	Phase V	Phase W
1	0	0	HIGH	X	LOW
1	1	0	X	HIGH	LOW
0	1	0	LOW	HIGH	X
0	1	1	LOW	X	HIGH
0	0	1	X	LOW	HIGH
1	0	1	HIGH	LOW	X

Parvalux standard flange/mount and shaft

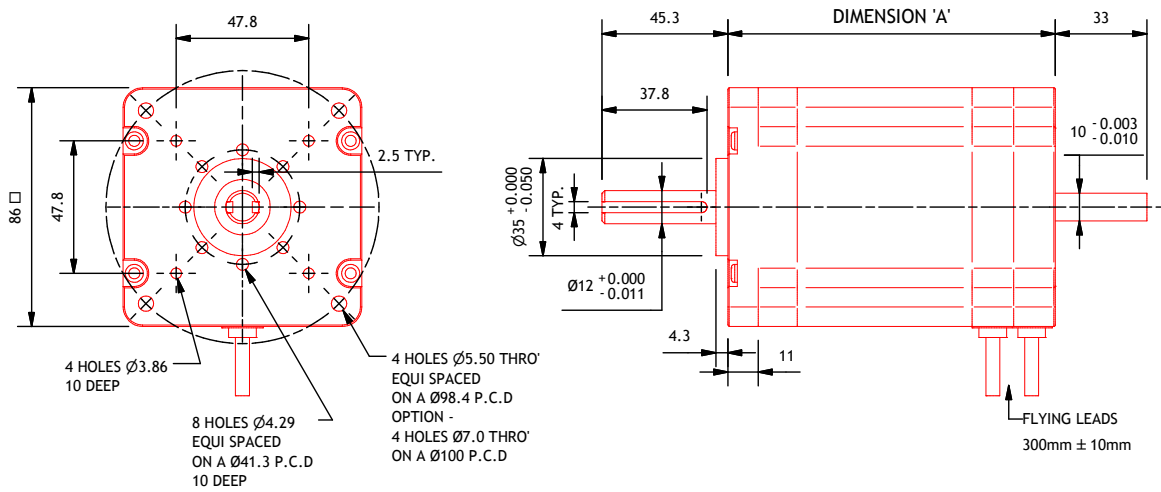

PBL86 motor and controller packages

Motor		PBL86-91	PBL86-91	PBL86-118	PBL86-145
Controller ref.		50B	B	50B	50B
Rated speed	rpm	3000	3000	3000	3000
Max speed	rpm	4000	4000	4000	4000
Rated torque	Nm	0.7	0.7	1.1	1.4
15 minute rating	Nm	0.9	0.8	1.5	2.1
Peak torque (duration 6 seconds)	Nm	1.4	1	2.2	2.8
DC bus voltage nominal	V	24	48	48	48
DC bus voltage min-max	V	16-32	36-58	16-58	16-58
DC bus current at no load and rated speed	A	1.1	0.6	0.8	1
DC bus current at rated torque and rated speed	A	11.8	5.9	8.7	11.2
Controller cont. current	A	25	10	25	25
Controller peak current	A	50	20	50	50

- The controllers we supply are matched for each motor in the range and tested as a pair with the motors during production.
- They operate from a 24V or 48V supply and have an analogue input for motor speed, an input for forward/reverse direction and a pulsed output to indicate motor speed.
- Most models have an additional input for enable/disable and an output indicating a fault condition.
- PBL86-118 and 145 motor and controller packages will operate from 24V supply with a rated speed of 2000rpm.

Torque/speed characteristics

Dotted line shows performance limit on 24V DC bus.

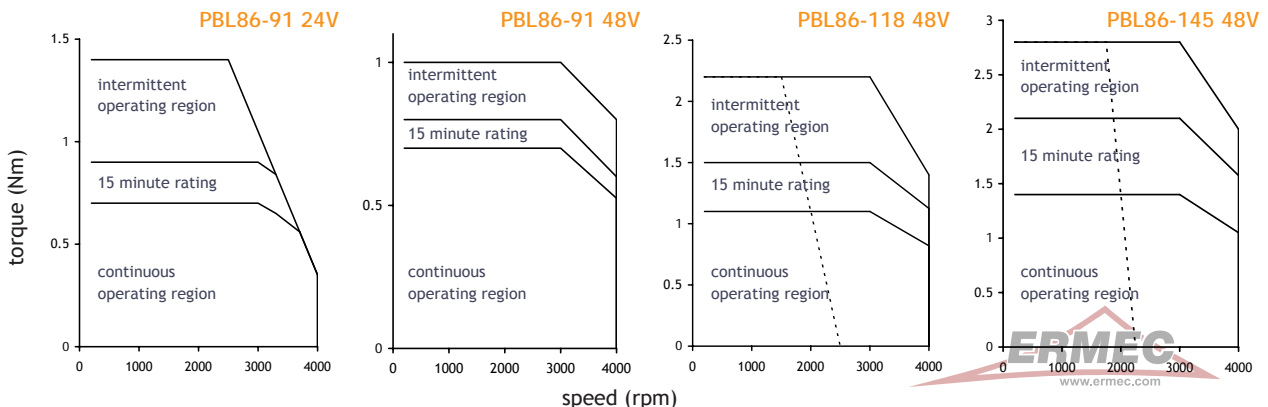

General tolerance on data is +/- 10%; Values shown are at normal operating temperature unless stated.

S controller



Controller type	Brushless DC controller 2 quadrant (reversible rotation)
Supply voltage	24 V DC (16-32 V)
Continuous current	PBLCS42-47 2.5 A PBLCS42-67 5 A
Peak current	2x continuous current
Control method	Closed loop speed control Block commutation with pulse width modulation (PWM)
Motor feedback	3 Hall sensors, 120 electrical degree spacing
Switching devices	6 MOSFET transistors
Switching frequency	18 kHz
Analogue speed input	Speed input for analogue voltage or potentiometer. A 4.7 k potentiometer is supplied. Maximum speed is preset during manufacture according to order. For fixed speed requirements, speed is preset during manufacture.
1 digital input (switch or TTL)	F/R connect to 0V for reverse (anticlockwise) rotation. Do not change status of F/R input while motor is rotating.
1 digital output (TTL)	PG Motor speed pulse output. Logic 1 (high) pulses 0.25 ms long Pulses per rev = 3 * number of poles. Frequency in Hz = (motor rpm/60) * 3 * number of poles.
1 status LED	PWR Lights when power is connected
Supply output for control circuits	0V and +5V provided for potentiometer etc. Max current 10 mA.
Construction	Aluminium chassis/heat sink Enclosed construction with pressed steel cover Slots for mounting screws provided on 2 faces
Connectors	Separate in-line connectors (3.5 mm pitch) for power supply, motor and control Mating connectors are supplied with controller
Weight	0.15 kg

S controller wiring example and outline drawing

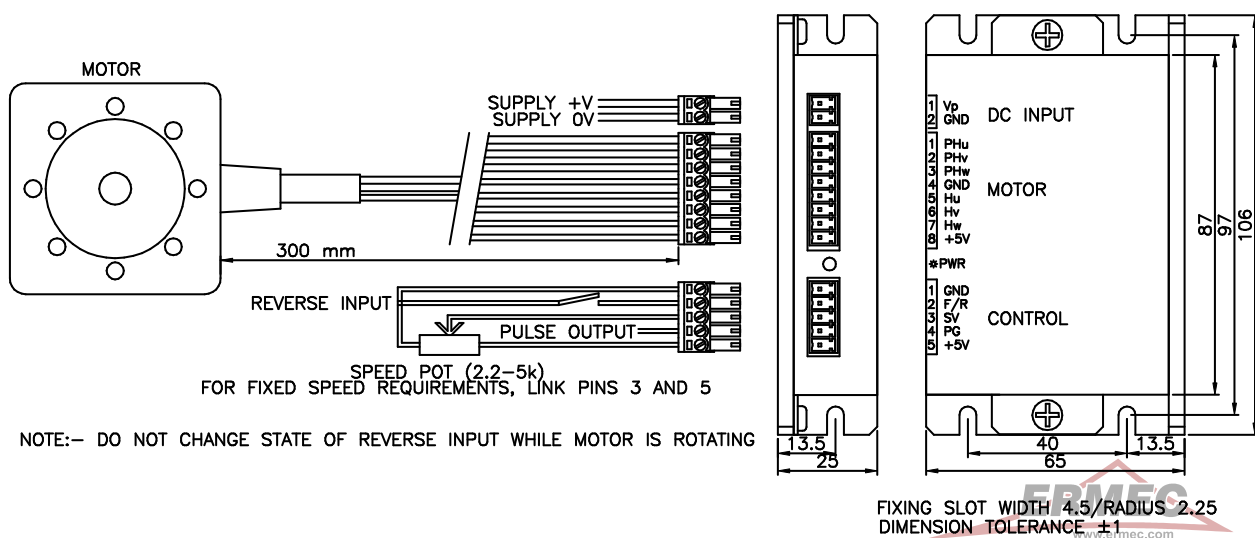

N and B controllers



Controller type	Brushless DC controller 2 quadrant (reversible rotation)
Supply voltage	24 V DC (16-32 V)
Continuous current	PBLCN42-87-24 7.5 A PBLCB42-107-24 10 A PBLCN60-78-24 5 A PBLCN60-98-24 7.5 A PBLCB60-118-24 10 A PBLCB60-138-24 15 A PBLCB86-91-48 10 A
Peak current	2x continuous current
Control method	Closed loop speed control Block commutation with pulse width modulation (PWM)
Motor feedback	3 Hall sensors, 120 electrical degree spacing
Switching devices	6 MOSFET transistors
Switching frequency	18 kHz
Analogue speed input	Speed input for analogue voltage or potentiometer Maximum speed is adjusted using SV ADJ. preset on side of controller. For controllers sold with geared motors, speed is preset during manufacture.
3 digital inputs (switch or TTL)	F/R connect to 0V for reverse (anticlockwise) rotation. -EN connect to 0V to enable. -BK connect to 0V to override speed pot and hold motor stationary. Do not change status of F/R and -BK inputs while motor is rotating.
2 digital outputs (open collector)	-PG Motor speed pulse output. Logic 0 (low) pulses 0.05 ms long Pulses per rev = 3 * number of poles. Frequency in Hz = (motor rpm/60) * 3 * number of poles. -ALM Fault output. Low under fault condition.
2 status LEDs	PWR/ALM Lights when power is connected. Blinks under fault condition eg peak current reached, supply voltage low, motor not connected. Blinks for a few seconds after continuous current exceeded. SHAFT Lights when shaft is turning
Supply output for control circuits	0V and +6.25V provided for potentiometer etc. Max current 10 mA.
Construction	Aluminium chassis/heat sink, finned on B controller Enclosed construction with pressed steel cover Slots for mounting screws provided on 2 faces
Connectors	Separate in-line connectors (5.08 mm pitch) for power supply, motor and control Mating connectors are supplied with controller
Weight	N controller 0.37 kg B controller 0.57 kg

N and B controller wiring example

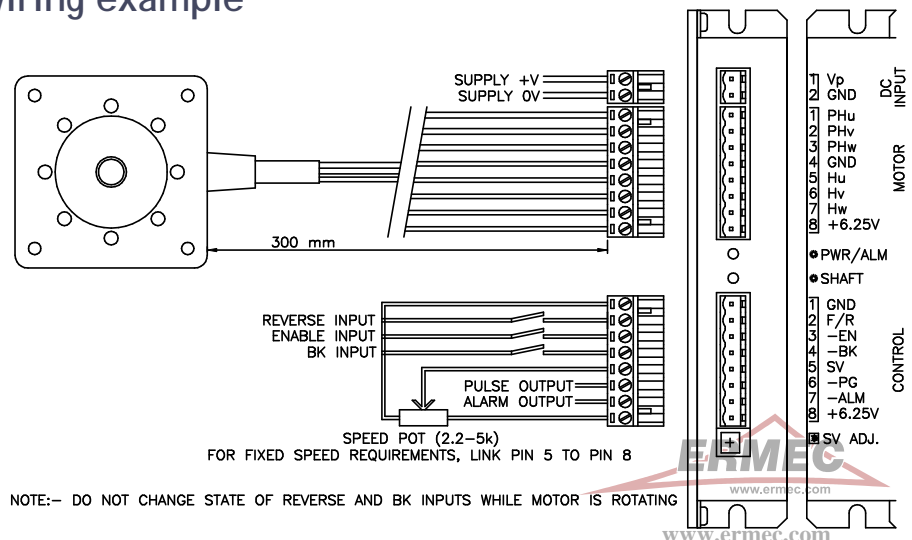

N and B controllers

N controller outline drawing

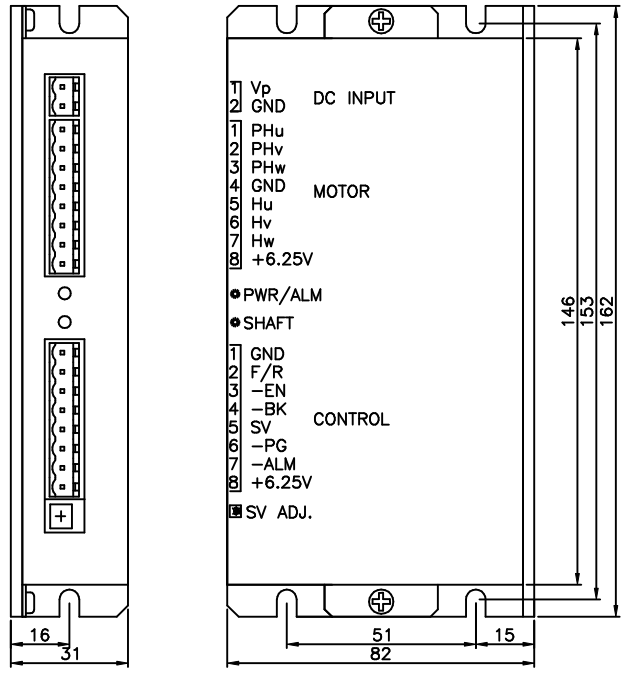

FIXING SLOT WIDTH 4.5/RADIUS 2.25
DIMENSION TOLERANCE ±1

B controller outline drawing

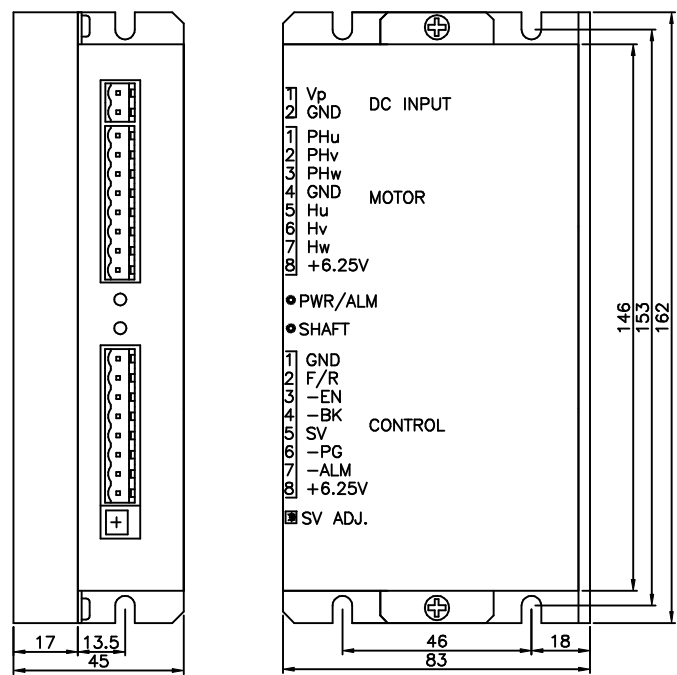

FIXING SLOT WIDTH 4.5/RADIUS 2.25
DIMENSION TOLERANCE ±1



50B controller



Controller type	Brushless DC controller 2 quadrant (reversible rotation)
Supply voltage	24 V DC or 48 V DC (16-58 V)
Continuous current	PBLC50B86-91-24 25 A PBLC50B86-118-48 25 A PBLC50B86-145-48 25 A
Peak current	2 x continuous current
Control method	Closed loop speed control Block commutation with pulse width modulation (PWM)
Motor feedback	3 Hall sensors, 120 electrical degree spacing
Switching devices	6 MOSFET transistors
Switching frequency	12 kHz
Analogue speed input	Speed input for analogue voltage or potentiometer Maximum speed is adjusted using SV ADJ. preset on side of controller. For controllers sold with geared motors, speed is preset during manufacture.
3 digital inputs (switch or TTL)	F/R connect to 0V for reverse (anticlockwise) rotation. -EN connect to 0V to enable. Do not change status of F/R input while motor is rotating.
2 digital outputs (open collector)	-PG Motor speed pulse output. Logic 0 (low) pulses 0.05 ms long Pulses per rev = 3 * number of poles. Frequency in Hz = (motor rpm/60) * 3 * number of poles. -ALM Fault output. Low under fault condition.
2 status LEDs	PWR/ALM Lights when power is connected. Blinks under fault condition eg peak current reached, supply voltage low, motor not connected. Blinks for a few seconds after continuous current exceeded. SHAFT Lights when shaft is turning
Supply output for control circuits	0V and +6.25V provided for potentiometer etc. Max current 10 mA.
Construction	Finned aluminium chassis/heat sink Enclosed construction with pressed steel cover Slots for mounting screws provided on 2 faces
Connectors	Separate in-line connectors for power supply (10.16 mm pitch), motor phases (10.16 mm pitch), motor feedback (3.5 mm pitch) and control (3.5 mm pitch) Mating connectors are supplied with controller
Weight	0.8 kg

50B controller wiring example and outline drawing

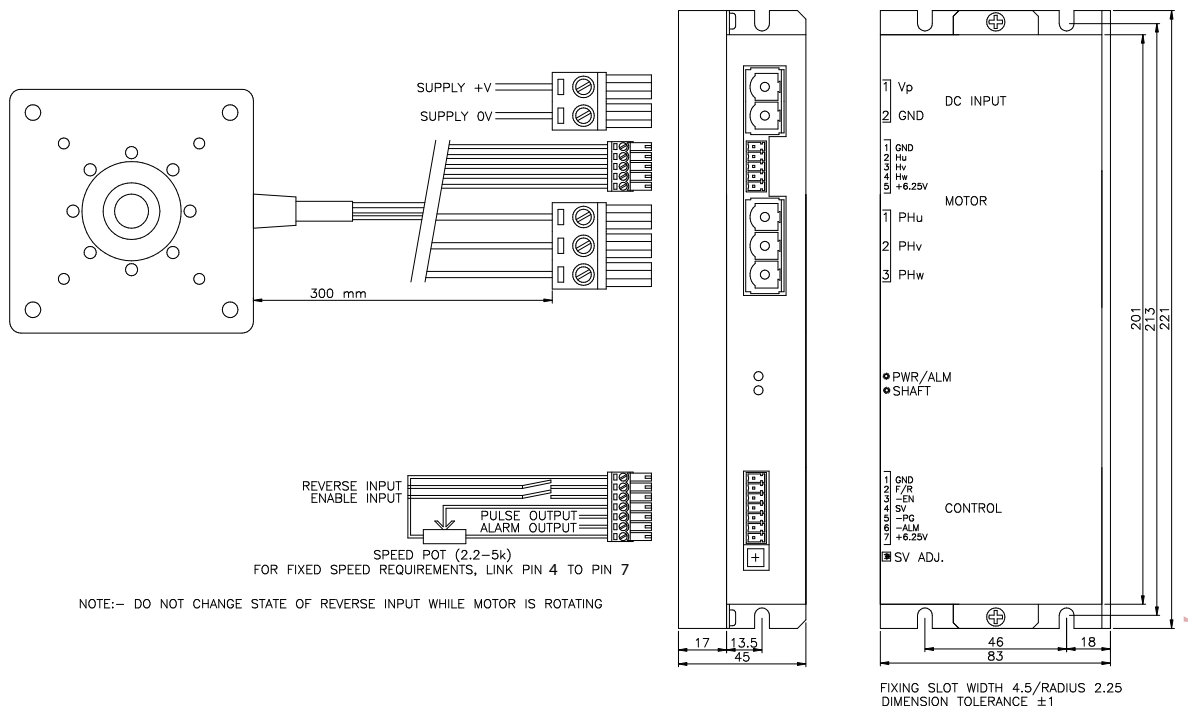

customisation options

Parvalux motors and gearboxes can be customised to the exact needs of the application. Increasingly, we are providing geared motor units with extra components specified by customers in order to provide a complete sub-assembly, saving both time and cost. Some of our many options are described below. If the option that you are looking for is not shown, please do not hesitate to contact us to discuss we may well have a solution that meets your needs.

Connector

We can fit a huge range of connectors or crimps to our motor cables according to your specification.

Brake

We provide a standard range of high-quality spring applied brakes to provide either static-holding or dynamic braking. Our standard ranges from 0.4Nm - 1.0Nm operating on a low voltage DC supply. Alternative brakes are available on request.

Encoder

We provide a standard range of HEDS compatible dual channel encoders offering 200 - 1250CPR output (500CPR as standard) with index pulse. These high-performance encoders are mounted to the rear of the motor; however, we are also able to provide custom-specific mounting on the gearbox output shaft. If an alternative style of encoder is required, we are happy to source an alternative or provide a custom-specific solution.

Terminal box

We offer a die cast terminal box (Ingress Protection IP54) for motor and brake connections with the PBL60 and PBL86 models, which is suitable for cable diameters up to 10mm (motor phases) and 7mm (Hall sensors). Includes 6-way AMP connector fitted to Hall effect sensor leads, earth screw for cable screens and two rear facing cable glands. Can be supplied with screened flying leads.

Bespoke solutions

As well as providing a large range of design options based on customising existing designs, we are able to provide bespoke solutions (out-and-out specials) for medium - high volume applications. In such cases our in-house design team are able to model new designs to allow rapid prototyping and test. With a strong design element as well as modern manufacturing and low cost supply chain, we are often able to provide cost-effective solutions quickly.

Paint finish

Standard paint finish is Parvalux blue applied to induction, series wound and permanent geared motors. Planetary geared motors are powder coated blue and DC brushless motors are painted black. Alternative paint colours are available on request.

Shaft

Motors are supplied with double ended shaft as standard or single ended shaft as an option. A blanking plug (3mm extra length) can be supplied fitted in the rear shaft hole on PBL60 and PBL86 motors with single ended shaft. In addition to the standard gearbox shafts shown in the catalogue, we can produce special keyways, flats and other special fittings to specific requirements. Shaft material as standard is a carbon-steel, alternative materials can be requested.

M3P

3 point fixing option
See page 57



S3P

3 point fixing option
See page 57



MF

flange option
See page 58



1.0 Nm holding brake

pictured with PBL86
See page 59



Incremental encoder

pictured with PBL60
See page 60



Terminal box

pictured with PBL60 and
3mm blanking plug

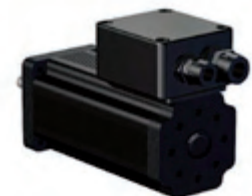

timing belt



gear



cross-hole



splined



flat



v-belt



keyway



threaded



selection guide

Type Code	Shaft Orientation	Power (Watts)*		Speed (rpm)		Torque (Nm)**		Load (N)		Pages
		Min	Max	Min	Max	Min	Max	Radial***	Axial	

motors only



PBL42	in-line	10	84	0	4000	0.06	0.20	****	****	4
PBL42IE	in-line	20	84	0	4000	0.125	0.20	****	****	6
PBL60	in-line	17	184	0	4000	0.11	0.44	****	****	8
PBL60IE	in-line	35	184	0	4000	0.22	0.44	****	****	10
PBL86	in-line	110	440	0	4000	0.70	1.40	****	****	12

worm



S	90°	10	84	38	640	0.30	3.50	69	35	20 - 23
M	90°	17	220	25	480	0.70	11.80	132	88	24 - 29
MB / MF	90°	17	220	25	480	0.70	11.80	226	108	24 - 29
LS / LSH	90°	17	346	25	432	0.70	19.20	314	196	30 - 35
G / GH	90°	110	440	20	240	6.60	50.00	491	294	36 - 38

in-line double worm



SIW	in-line	17	134	1.1	102	2.50	11.30	78	49	39 - 41
MIW	in-line	17	184	1.1	77	3.20	28.00	265	132	42 - 45

worm spur



SWS	90°	10	52	1.1	45	3.60	11.00	177	112	46 - 47
MWS	90°	17	134	1.1	98	3.30	45.00	353	177	48 - 50
LWS	90°	17	184	0.8	80	3.40	100.00	446	226	51 - 54
GWS	90°	50	184	0.5	44	19.40	250.00	667	353	55 - 56

* Continuous rated power

** Continuous output torque

*** Radial loads are measured at the mid-point of the shaft extension

**** On application

PBL42-47S

MOTOR	Brushless DC motor
PROTECTION	IP54 (IP50 at exposed rear motor shaft)
GEARBOX	Worm and wheel (S)
MOTOR POWER	10 - 26 Watts
SPEED*	38 - 640 rpm
VOLTAGE	24V DC
WEIGHT	0.8 kg
CONTROLLER	S
SHAFT TYPE	Single ended or double ended upon request
EXTRAS	See page 18



*input speed variable up to 4000 rpm; other ratios available on request

See page 61 to specify shaft and gearbox position

Ratio	Final speed (rpm)				Rated torque Nm up to 4000 rpm		Peak torque Nm up to 2000 rpm		15 min rating Nm up to 3500 rpm	
	1500 rpm 10 W	2000 rpm 13 W	3000 rpm 20 W	4000 rpm 26W	Composite	Bronze	Composite	Bronze	Composite	Bronze
40:1	38	50	75	100	1.1	-	2.2	-	1.4	-
36:1	42	56	83	111	1	-	2	-	1.3	-
33:1	45	61	91	121	1	-	1.9	-	1.2	-
27:1	56	74	111	148	0.9	-	1.7	-	1.1	-
20 1/2:1	73	98	146	195	0.7	-	1.4	-	0.9	-
18 1/2:1	81	108	162	216	0.7	-	1.3	-	0.8	-
16 1/2:1	91	121	182	242	0.6	-	1.2	-	0.8	-
12 1/2:1	120	160	240	320	0.5	-	1	-	0.6	-
11 1/3:1	132	176	265	353	0.5	-	0.9	-	0.6	-
10 1/3:1	145	194	290	387	0.4	-	0.9	-	0.5	-
8 1/3:1	180	240	360	480	0.4	-	0.7	-	0.5	-
6 1/4:1	240	320	480	640	0.3	-	0.6	-	0.4	-

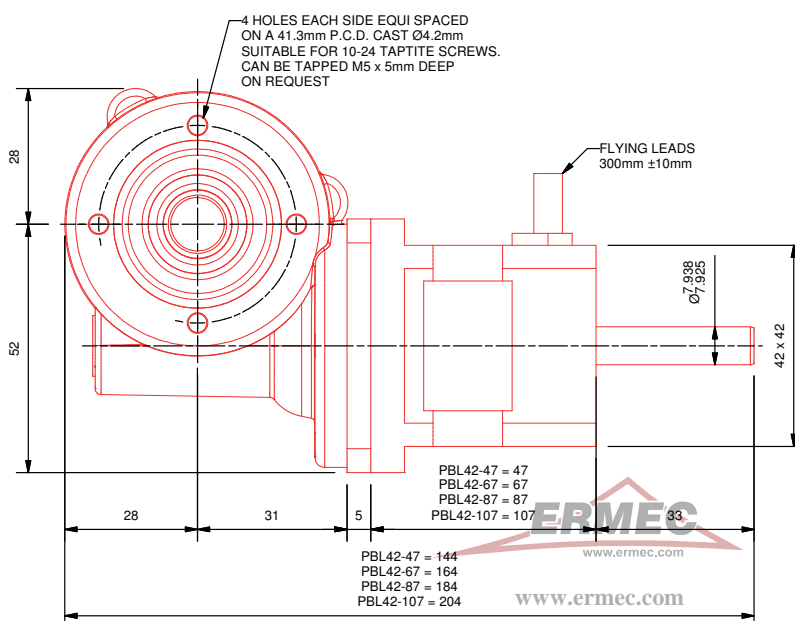
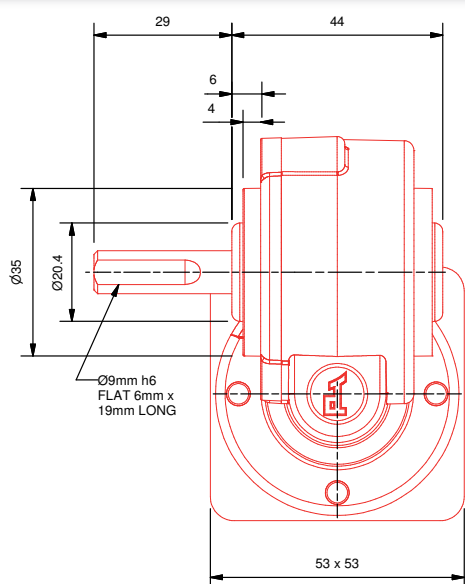

PBL42-87(IE)S

MOTOR	Brushless DC motor
PROTECTION	IP54 (IP50 at exposed rear motor shaft)
GEARBOX	Worm and wheel (S)
MOTOR POWER	27 - 71 Watts
SPEED*	38 - 640 rpm
VOLTAGE	24V DC
WEIGHT	1.1 kg
CONTROLLER	N (or integral with IE model)
SHAFT TYPE	Single ended or double ended upon request
EXTRAS	See page 18



PBL42-87S pictured

See page 61 to specify shaft and gearbox position

*input speed variable up to 4000 rpm; other ratios available on request

Ratio	Final speed (rpm)				Rated torque Nm up to 4000 rpm		Peak torque Nm up to 2000 rpm		15 min rating Nm up to 3500 rpm	
	1500 rpm 27 W	2000 rpm 36 W	3000 rpm 53 W	4000 rpm 71 W	Composite	Bronze	Composite	Bronze	Composite	Bronze
40:1	38	50	75*	100*	2.9	3	2.9	4.5	2.9	4
36:1	42	56	83*	111*	2.8	2.8	2.9	4.5	2.9	3.8
33:1	45	61	91*	121*	2.6	2.6	2.9	4.5	2.9	3.6
27:1	56	74	111*	148*	2.3	2.3	2.9	4.5	2.9	3.1
20 1/2:1	73	98	146*	195*	1.9	1.9	2.9	4.2	2.6	2.6
18 1/2:1	81	108	162*	216*	1.8	1.8	2.9	3.9	2.4	2.4
16 1/2:1	91	121	182*	242*	1.7	1.7	2.9	3.6	2.3	2.3
12 1/2:1	120	160	240	320*	1.4	1.4	2.9	3	1.9	1.9
11 1/3:1	132	176	265	353*	1.3	-	2.8	-	1.7	-
10 1/3:1	145	194	290	387*	1.2	-	2.6	-	1.6	-
8 1/3:1	180	240	360	480	1	-	2.2	-	1.4	-
6 1/4:1	240	320	480	640	0.8	-	1.8	-	1.1	-

* Please refer to the information regarding thermal rating on page 64 for these combinations of motor speed and gear ratio

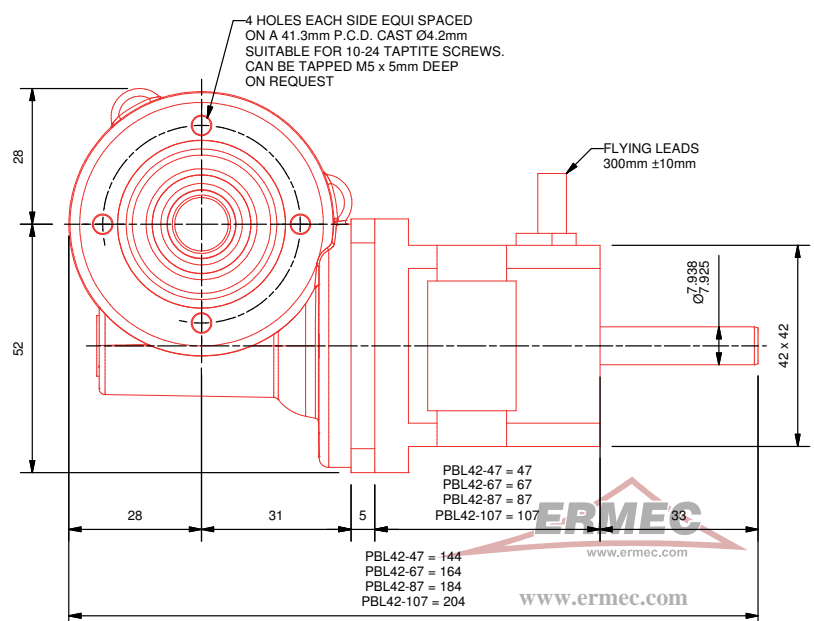
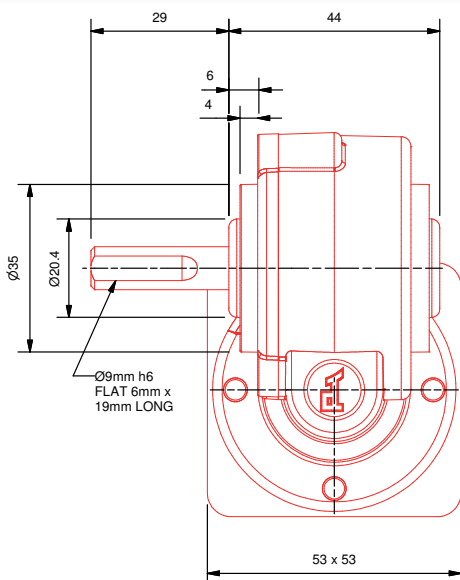

PBL42-107(IE)S

MOTOR	Brushless DC motor
PROTECTION	IP54 (IP50 at exposed rear motor shaft)
GEARBOX	Worm and wheel (S)
MOTOR POWER	31 - 84 Watts
SPEED*	38 - 640 rpm
VOLTAGE	24V DC
WEIGHT	1.3 kg
CONTROLLER	B (or integral with IE model)
SHAFT TYPE	Single ended or double ended upon request
EXTRAS	See page 18



PBL42-107S pictured

See page 61 to specify shaft and gearbox position

*input speed variable up to 4000 rpm; other ratios available on request

Ratio	Final speed (rpm)				Rated torque Nm up to 4000 rpm		Peak torque Nm up to 2000 rpm		15 min rating Nm up to 3500 rpm	
	1500 rpm 31 W	2000 rpm 42 W	3000 rpm 63 W	4000 rpm 84 W	Composite	Bronze	Composite	Bronze	Composite	Bronze
40:1	38	50	75*	100*	2.9	3.5	2.9	4.5	2.9	4.5
36:1	42	56*	83*	111*	2.9	3.3	2.9	4.5	2.9	4.5
33:1	45	61*	91*	121*	2.9	3.1	2.9	4.5	2.9	4.5
27:1	56	74*	111*	148*	2.7	2.7	2.9	4.5	2.9	4.2
20 1/2:1	73	98	146*	195*	2.3	2.3	2.9	4.5	2.9	3.5
18 1/2:1	81	108	162*	216*	2.1	2.1	2.9	4.5	2.9	3.3
16 1/2:1	91	121	182*	242*	2	2	2.9	4.5	2.9	3
12 1/2:1	120	160	240*	320*	1.6	1.6	2.9	4	2.5	2.5
11 1/3:1	132	176	265*	353*	1.5	1.5	2.9	3.8	2.3	2.3
10 1/3:1	145	194	290*	387*	1.4	1.4	2.9	3.5	2.2	2.2
8 1/3:1	180	240	360	480*	1.2	1.2	2.9	3	1.9	1.9
6 1/4:1	240	320	480	640*	1	-	2.4	-	1.5	-

* Please refer to the information regarding thermal rating on page 64 for these combinations of motor speed and gear ratio

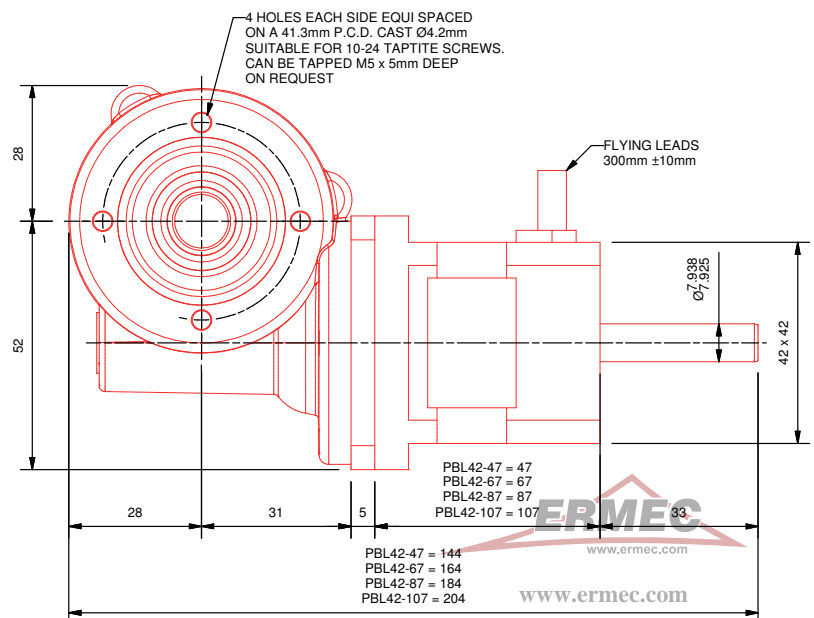
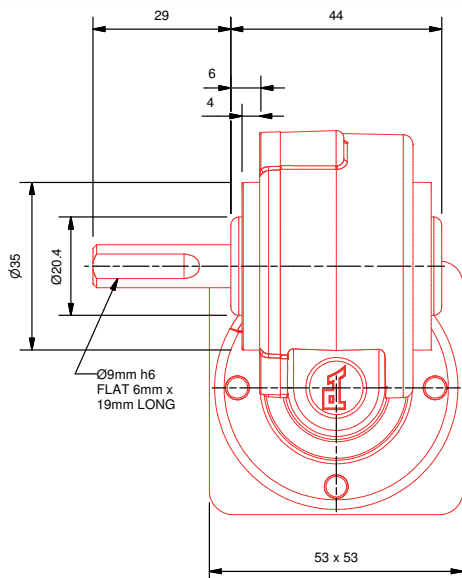

PBL60-78M/MB

MOTOR	Brushless DC motor
PROTECTION	IP54 (IP50 at exposed rear motor shaft)
GEARBOX	Worm and wheel (M)
MOTOR POWER	17 - 46 Watts
SPEED*	25 - 480 rpm
VOLTAGE	24V DC
WEIGHT	1.4 kg
CONTROLLER	N
SHAFT TYPE	Single ended as standard; hollow or double ended upon request
EXTRAS	See page 18



PBL60-78M pictured

See page 61 to specify shaft and gearbox position

*input speed variable up to 4000 rpm; other ratios available on request

Ratio	Final speed (rpm)				Rated torque Nm up to 4000 rpm		Peak torque Nm up to 2500 rpm		15 min rating Nm up to 3500 rpm	
	1500 rpm 17 W	2000 rpm 23 W	3000 rpm 35 W	4000 rpm 46 W	Composite	Bronze	Composite	Bronze	Composite	Bronze
60:1	25	33	50	67	2.4	-	4.8	-	3	-
48:1	31	42	63	83	2.1	-	4.3	-	2.7	-
40:1	38	50	75	100	1.9	-	3.8	-	2.4	-
30:1	50	67	100	133	1.6	-	3.2	-	2	-
25:1	60	80	120	160	1.4	-	2.9	-	1.8	-
16 1/2:1	91	121	182	242	1.1	-	2.2	-	1.4	-
15 1/2:1	97	129	194	258	1	-	2.1	-	1.3	-
12 1/3:1	122	162	243	324	0.9	-	1.8	-	1.1	-
10 1/3:1	145	194	290	387	0.8	-	1.5	-	1	-
9 1/3:1	161	214	321	429	0.7	-	1.4	-	0.9	-
8 1/3:1	180	240	360	480	0.7	-	1.3	-	0.8	-

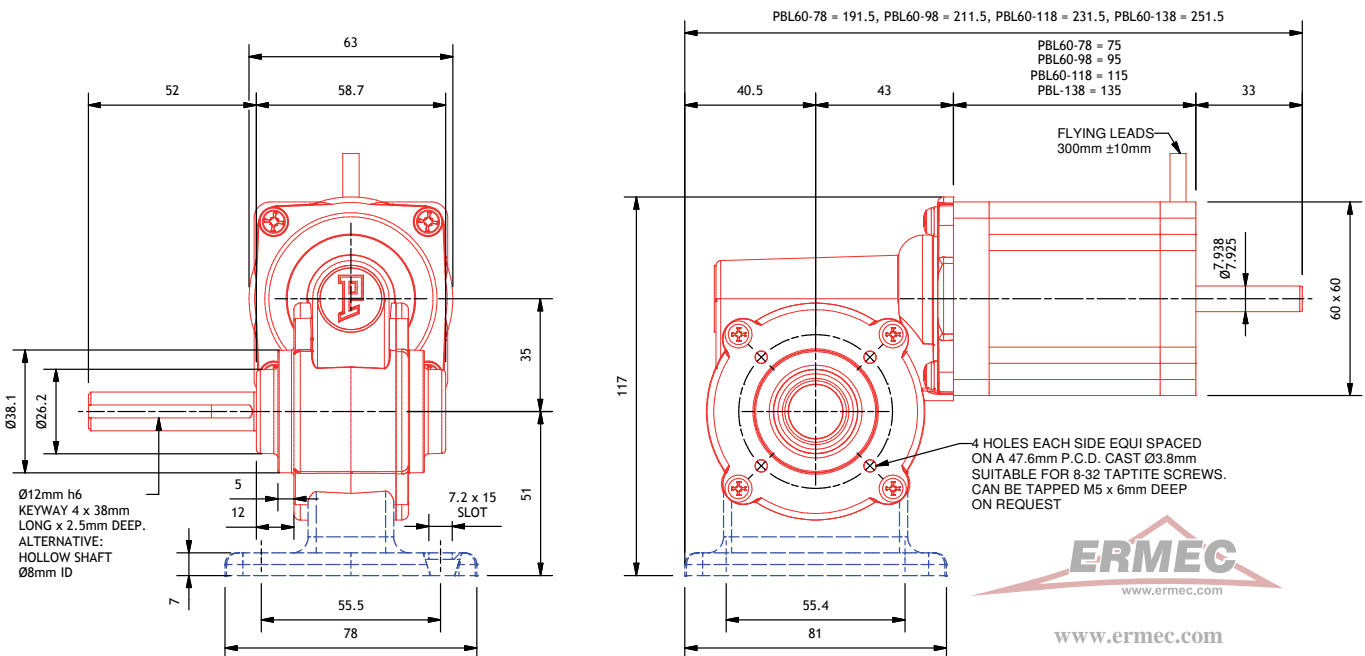

PBL60-98(IE)M/MB

MOTOR	Brushless DC motor
PROTECTION	IP54 (IP50 at exposed rear motor shaft)
GEARBOX	Worm and wheel (M)
MOTOR POWER	35 - 92 Watts
SPEED*	25 - 480 rpm
VOLTAGE	24V DC
WEIGHT	1.7 kg
CONTROLLER	N (or integral with IE model)
SHAFT TYPE	Single ended as standard; hollow or double ended upon request
EXTRAS	See page 18



PBL60-98M pictured

See page 61 to specify shaft and gearbox position

*input speed variable up to 4000 rpm; other ratios available on request

Ratio	Final speed (rpm)				Rated torque Nm up to 4000 rpm		Peak torque Nm up to 2500 rpm		15 min rating Nm up to 3500 rpm	
	1500 rpm 35W	2000 rpm 46 W	3000 rpm 69 W	4000 rpm 92 W	Composite	Bronze	Composite	Bronze	Composite	Bronze
60:1	25	33	50*	67*	4.8	4.8	5.9	7.9	5.9	6.1
48:1	31	42	63*	83*	4.3	4.3	5.9	7.9	5.4	5.4
40:1	38	50	75*	100*	3.8	-	7.7	-	4.9	-
30:1	50	67	100	133*	3.2	-	6.4	-	4.1	-
25:1	60	80	120	160*	2.9	-	5.7	-	3.6	-
16 1/2:1	91	121	182	242	2.2	-	4.3	-	2.8	-
15 1/2:1	97	129	194	258	2.1	-	4.1	-	2.6	-
12 1/3:1	122	162	243	324	1.8	-	3.5	-	2.2	-
10 1/3:1	145	194	290	387	1.5	-	3.1	-	2	-
9 1/3:1	161	214	321	429	1.4	-	2.9	-	1.8	-
8 1/3:1	180	240	360	480	1.3	-	2.6	-	1.7	-

* Please refer to the information regarding thermal rating on page 64 for these combinations of motor speed and gear ratio

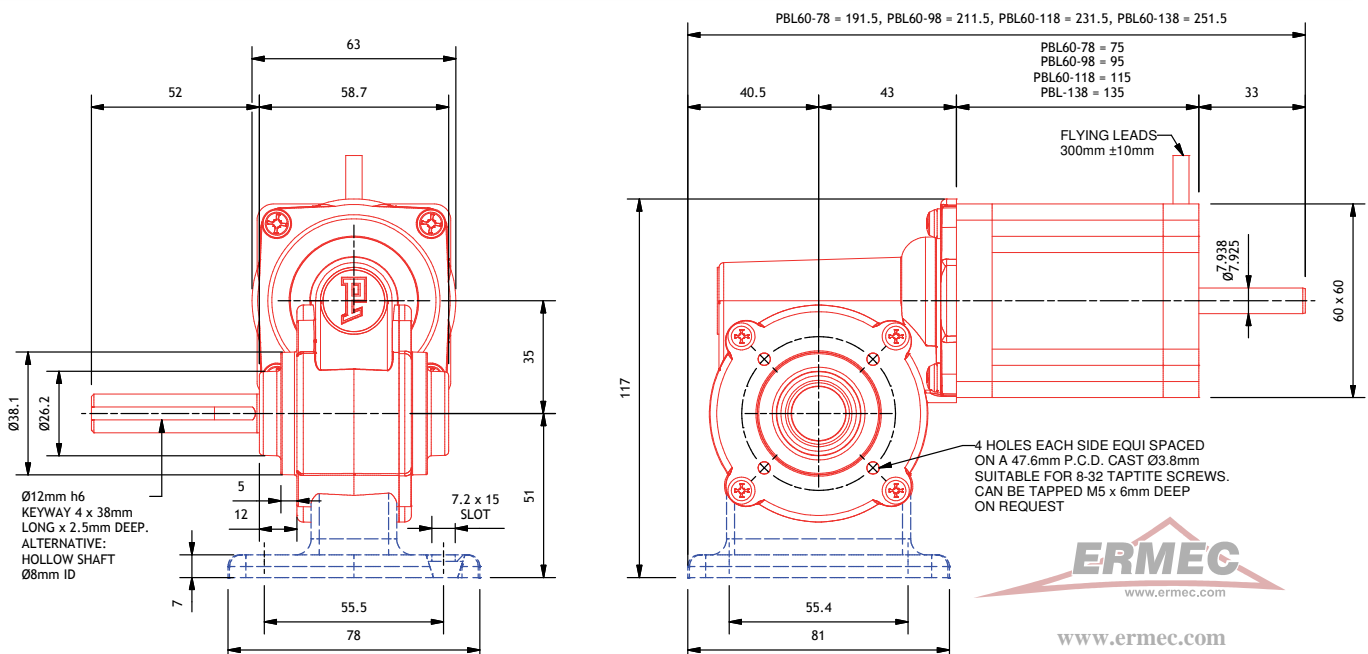

PBL60-118(IE)M/MB

MOTOR	Brushless DC motor
PROTECTION	IP54 (IP50 at exposed rear motor shaft)
GEARBOX	Worm and wheel (M)
MOTOR POWER	50 - 134 Watts
SPEED*	25 - 480 rpm
VOLTAGE	24V DC
WEIGHT	2.0 kg
CONTROLLER	B (or integral with IE model)
SHAFT TYPE	Single ended as standard; hollow or double ended upon request
EXTRAS	See page 18

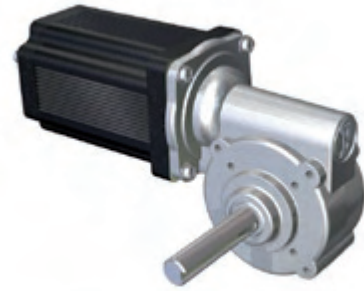

PBL60-118M pictured

See page 61 to specify shaft and gearbox position

*input speed variable up to 4000 rpm; other ratios available on request

Ratio	Final speed (r.p.m)				Rated torque Nm up to 4000 rpm		Peak torque Nm up to 2500 rpm		15 min rating Nm up to 3500 rpm	
	1500 rpm 50 W	2000 rpm 67 W	3000 rpm 101 W	4000 rpm 134 W	Composite	Bronze	Composite	Bronze	Composite	Bronze
60:1	25	33	50*	67*	5.9	7	5.9	7.9	5.9	7.9
48:1	31	42*	63*	83*	5.9	6.2	5.9	7.9	5.9	7.7
40:1	38	50	75*	100*	5.6	5.6	7.9	11.2	7	7
30:1	50	67	100*	133*	4.7	4.7	7.9	9.4	5.9	5.9
25:1	60	80	120*	160*	4.2	4.2	7.9	8.3	5.2	5.2
16 1/2:1	91	121	182*	242*	3.1	-	6.3	-	3.9	-
15 1/2:1	97	129	194*	258*	3	-	6	-	3.8	-
12 1/3:1	122	162	243	324*	2.6	-	5.1	-	3.2	-
10 1/3:1	145	194	290	387*	2.2	-	4.5	-	2.8	-
9 1/3:1	161	214	321	429*	2.1	-	4.2	-	2.6	-
8 1/3:1	180	240	360	480	1.9	-	3.8	-	2.4	-

* Please refer to the information regarding thermal rating on page 64 for these combinations of motor speed and gear ratio

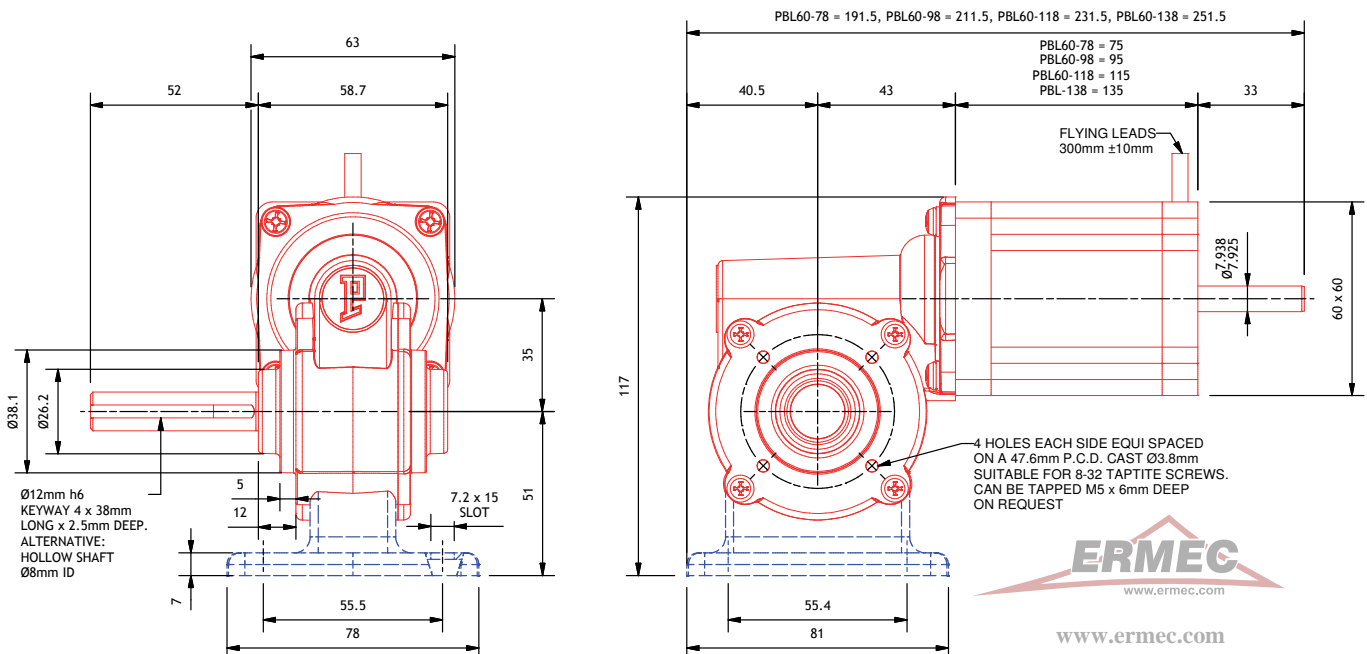

PBL60-138(IE)M/MB

MOTOR	Brushless DC motor
PROTECTION	IP54 (IP50 at exposed rear motor shaft)
GEARBOX	Worm and wheel (M)
MOTOR POWER	69 - 184 Watts
SPEED*	25 - 480 rpm
VOLTAGE	24V DC (or 48V DC with IE model)
WEIGHT	2.3 kg
CONTROLLER	B (or integral with IE model)
SHAFT TYPE	Single ended as standard; hollow or double ended upon request
EXTRAS	See page 18



PBL60-138M pictured

See page 61 to specify shaft and gearbox position

*input speed variable up to 4000 rpm; other ratios available on request

Ratio	Final speed (rpm)				Rated torque Nm up to 4000 rpm		Peak torque Nm up to 2500 rpm		15 min rating Nm up to 3500 rpm	
	1500 rpm 69 W	2000 rpm 92 W	3000 rpm 138 W	4000 rpm 184 W	Composite	Bronze	Composite	Bronze	Composite	Bronze
60:1	25	33	50*	67*	5.9	7.9	5.9	7.9	5.9	7.9
48:1	31	42*	63*	83*	5.9	7.9	5.9	7.9	5.9	7.9
40:1	38*	50*	75*	100*	7.7	7.7	7.9	11.8	7.9	9.6
30:1	50	67*	100*	133*	6.4	6.4	7.9	11.8	7.9	8
25:1	60	80*	120*	160*	5.7	5.7	7.9	11.5	7.2	7.2
16 1/2:1	91	121	182*	242*	4.3	4.3	7.9	8.6	5.4	5.4
15 1/2:1	97	129	194*	258*	4.1	4.1	7.9	8.3	5.2	5.2
12 1/3:1	122	162	243*	324*	3.5	-	7	-	4.4	-
10 1/3:1	145	194	290*	387*	3.1	-	6.2	-	3.9	-
9 1/3:1	161	214	321*	429*	2.9	-	5.7	-	3.6	-
8 1/3:1	180	240	360*	480*	2.6	-	5.3	-	3.3	-

* Please refer to the information regarding thermal rating on page 64 for these combinations of motor speed and gear ratio

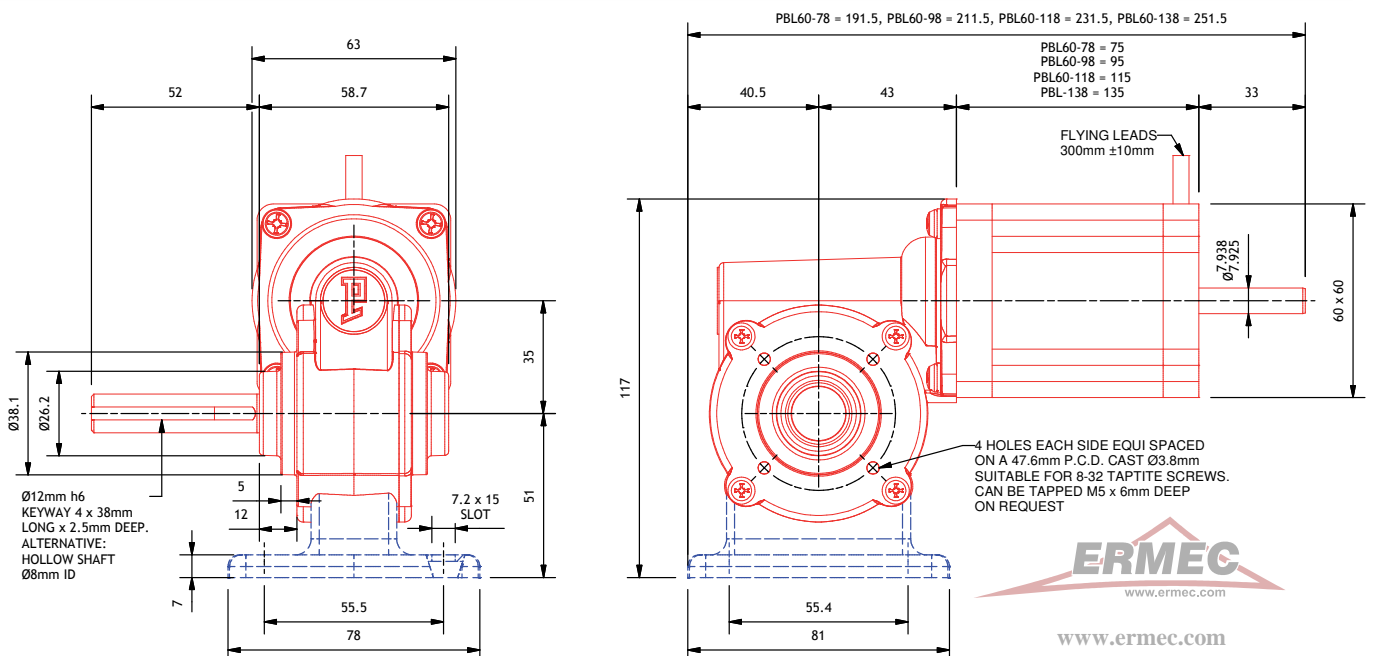

PBL86-91M/MB 24V

MOTOR	Brushless DC motor
PROTECTION	IP54 (IP50 at exposed rear motor shaft)
GEARBOX	Worm and wheel (M)
MOTOR POWER	110 - 220 Watts
SPEED*	25 - 360 rpm
VOLTAGE	24V DC
WEIGHT	2.9 kg
CONTROLLER	50B
SHAFT TYPE	Single ended as standard; hollow or double ended upon request
EXTRAS	See page 18



PBL86-91M pictured

See page 61 to specify shaft and gearbox position

*input speed variable up to 4000 rpm; other ratios available on request

Ratio	Final speed (rpm)			Rated torque Nm up to 3000 rpm		Peak torque Nm up to 2500 rpm		15min rating Nm up to 3000 rpm	
	1500 rpm 110 W	2000 rpm 147 W	3000 rpm 220 W	Composite	Bronze	Composite	Bronze	Composite	Bronze
60:1	25	33	50*	5.9	7.9	5.9	7.9	5.9	7.9
48:1	31	42*	63*	5.9	7.9	5.9	7.9	5.9	7.9
40:1	38*	50*	75*	7.9	11.8	7.9	11.8	7.9	11.8
30:1	50*	67*	100*	7.9	10.2	7.9	11.8	7.9	11.8
25:1	60*	80*	120*	7.9	9.1	7.9	11.8	7.9	11.7
16 1/2:1	91*	121*	182*	6.9	6.9	7.9	11.8	7.9	8.8
15 1/2:1	97*	129*	194*	6.6	6.6	7.9	11.8	7.9	8.5
12 1/3:1	122*	162*	243*	5.6	5.6	7.9	11.2	7.2	7.2
10 1/3:1	145	194*	290*	4.9	4.9	7.9	9.8	6.3	6.3
9 1/3:1	161	214*	321*	4.6	4.6	7.9	9.1	5.9	5.9
8 1/3:1	180	240*	360*	4.2	4.2	7.9	8.4	5.4	5.4

* Please refer to the information regarding thermal rating on page 64 for these combinations of motor speed and gear ratio

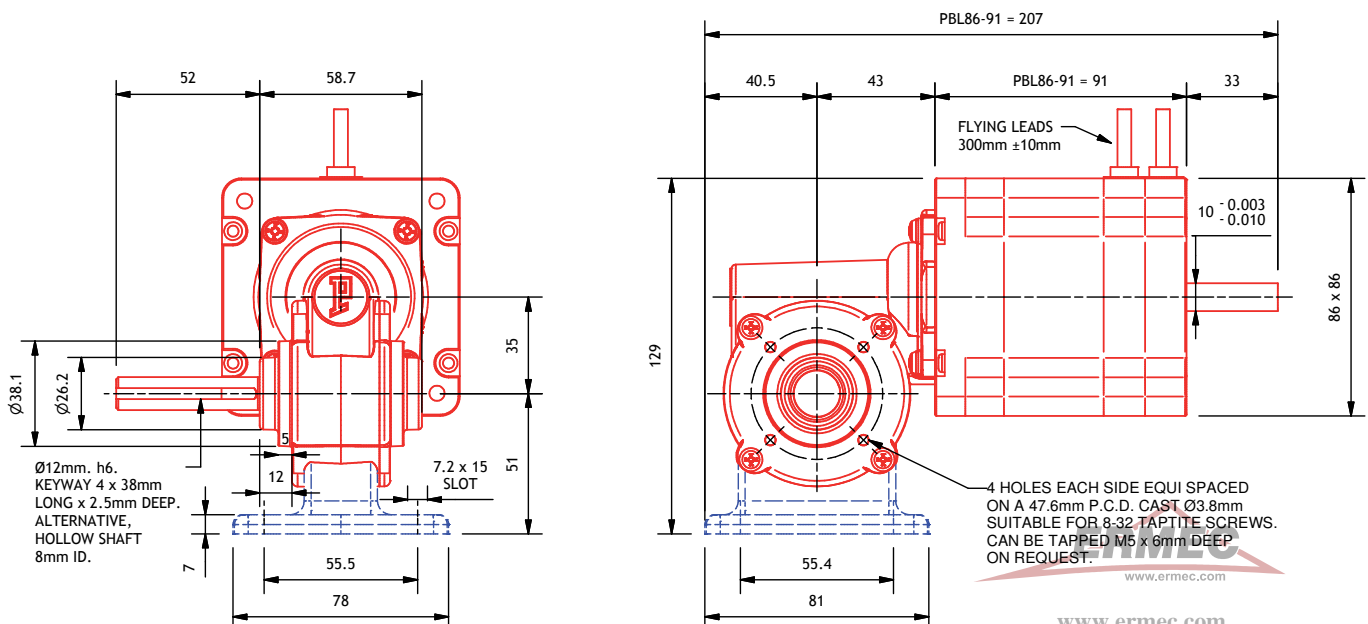

PBL86-91M/MB 48V

MOTOR	Brushless DC motor
PROTECTION	IP54 (IP50 at exposed rear motor shaft)
GEARBOX	Worm and wheel (M)
MOTOR POWER	110 - 220 Watts
SPEED*	25 - 360 rpm
VOLTAGE	48V DC
WEIGHT	2.9 kg
CONTROLLER	B
SHAFT TYPE	Single ended as standard; hollow or double ended upon request
EXTRAS	See page 18



PBL86-91M pictured

See page 61 to specify shaft and gearbox position

*input speed variable up to 4000 rpm; other ratios available on request

Ratio	Final speed (rpm)			Rated torque Nm up to 3000 rpm		Peak torque Nm up to 3000 rpm		15min rating Nm up to 3000 rpm	
	1500 rpm 110 W	2000 rpm 147 W	3000 rpm 220 W	Composite	Bronze	Composite	Bronze	Composite	Bronze
60:1	25	33	50*	5.9	7.9	5.9	7.9	5.9	7.9
48:1	31	42*	63*	5.9	7.9	5.9	7.9	5.9	7.9
40:1	38*	50*	75*	7.9	11.8	7.9	11.8	7.9	11.8
30:1	50*	67*	100*	7.9	10.2	7.9	11.8	7.9	11.7
25:1	60*	80*	120*	7.9	9.1	7.9	11.8	7.9	10.4
16 1/2:1	91*	121*	182*	6.9	6.9	7.9	9.8	7.9	7.9
15 1/2:1	97*	129*	194*	6.6	6.6	7.9	9.4	7.5	7.5
12 1/3:1	122*	162*	243*	5.6	5.6	7.9	8	6.4	6.4
10 1/3:1	145	194*	290*	4.9	-	7	-	5.6	-
9 1/3:1	161	214*	321*	4.6	-	6.5	-	5.2	-
8 1/3:1	180	240*	360*	4.2	-	6	-	4.8	-

* Please refer to the information regarding thermal rating on page 64 for these combinations of motor speed and gear ratio

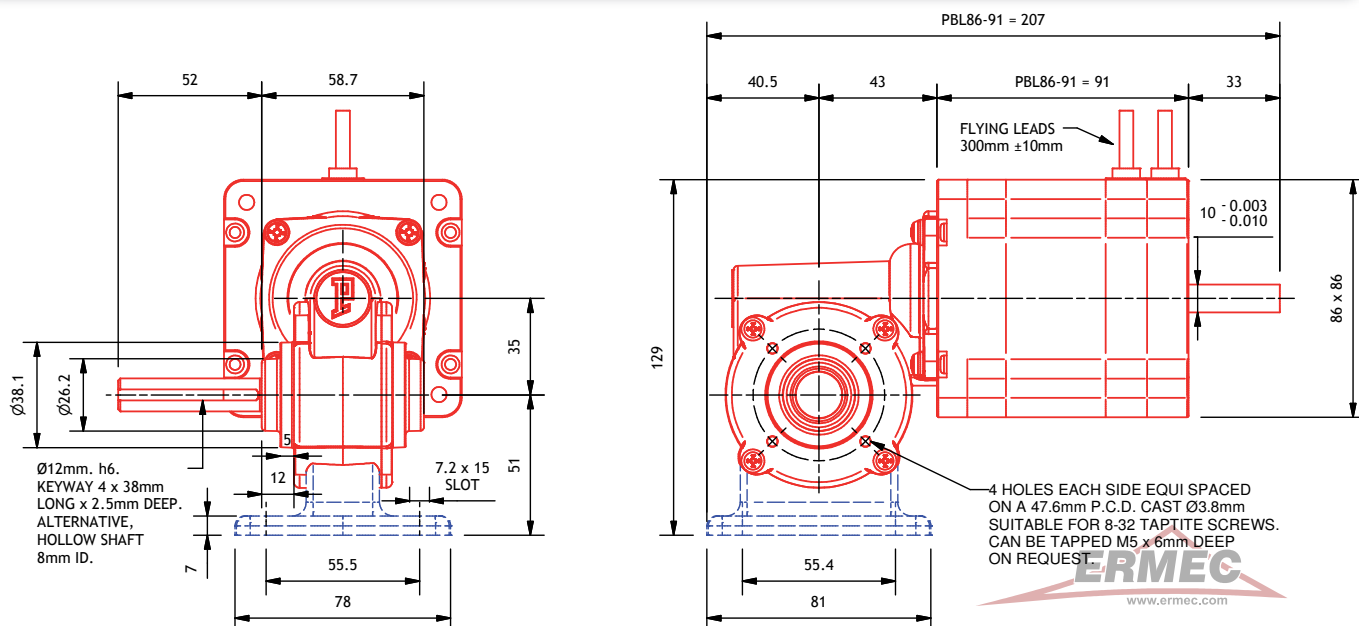

PBL60-78LS/LSH

MOTOR	Brushless DC motor
PROTECTION	IP54 (IP50 at exposed rear motor shaft)
GEARBOX	Worm and wheel (LS)
MOTOR POWER	17 - 46 Watts
SPEED*	25 - 432 rpm
VOLTAGE	24V DC
WEIGHT	1.8 kg
CONTROLLER	N
SHAFT TYPE	Single ended as standard; hollow or double ended upon request
EXTRAS	See page 18



PBL60-78LS pictured

See page 61 to specify shaft and gearbox position

*input speed variable up to 4000 rpm; other ratios available on request

Ratio	Final speed (rpm)				Rated torque Nm up to 4000 rpm		Peak torque Nm up to 2500 rpm		15 min rating Nm up to 3500 rpm	
	1500 rpm 17 W	2000 rpm 23 W	3000 rpm 35 W	4000 rpm 46 W	Composite	Bronze	Composite	Bronze	Composite	Bronze
60:1	25	33	50	67	2.4	-	4.8	-	3	-
50:1	30	40	60	80	2.2	-	4.4	-	2.8	-
40:1	38	50	75	100	1.9	-	3.8	-	2.4	-
30 1/2:1	49	66	98	131	1.6	-	3.3	-	2.1	-
25 1/2:1	59	78	118	157	1.5	-	2.9	-	1.8	-
20 1/2:1	73	98	146	195	1.3	-	2.5	-	1.6	-
15 1/3:1	98	130	196	261	1	-	2.1	-	1.3	-
12 1/3:1	122	162	243	324	0.9	-	1.8	-	1.1	-
9 1/4:1	162	216	324	432	0.7	-	1.4	-	0.9	-

PBL86-78 = 229
 PBL60-98 = 249
 PBL60-118 = 269
 PBL-138 = 289

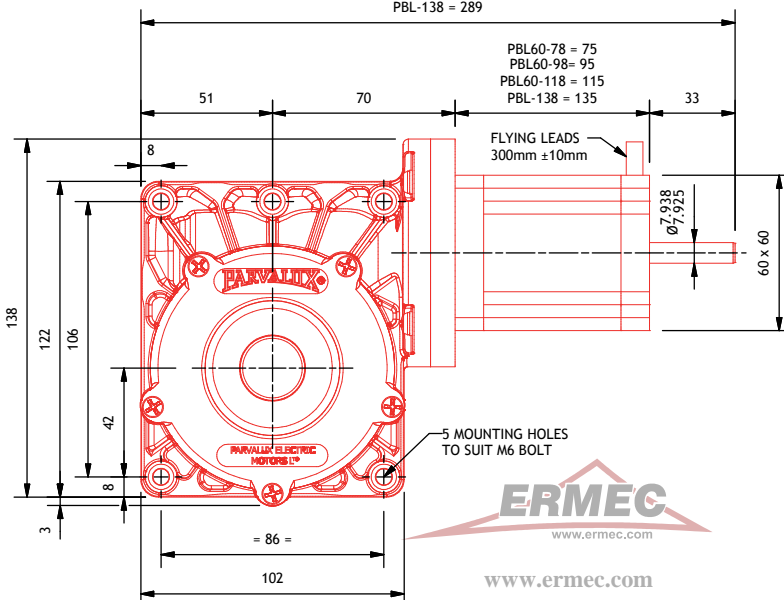
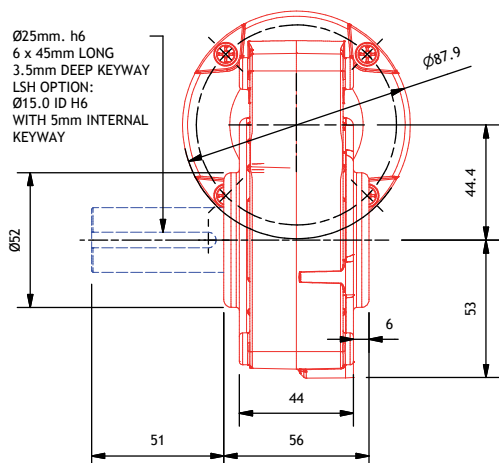

PBL60-98(IE)LS/LSH

MOTOR	Brushless DC motor
PROTECTION	IP54 (IP50 at exposed rear motor shaft)
GEARBOX	Worm and wheel (LS)
MOTOR POWER	35 - 92 Watts
SPEED*	25 - 432 rpm
VOLTAGE	24V DC
WEIGHT	2.1 kg
CONTROLLER	N (or integral with IE model)
SHAFT TYPE	Single ended as standard; hollow or double ended upon request
EXTRAS	See page 18



PBL60-98LS pictured

See page 61 to specify shaft and gearbox position

*input speed variable up to 4000 rpm; other ratios available on request

Ratio	Final speed (rpm)				Rated torque Nm up to 4000 rpm		Peak torque Nm up to 2500 rpm		15 min rating Nm up to 3500 rpm	
	1500 rpm 35 W	2000 rpm 46 W	3000 rpm 69 W	4000 rpm 92 W	Composite	Bronze	Composite	Bronze	Composite	Bronze
60:1	25	33	50	67	4.8	-	9.6	-	6.1	-
50:1	30	40	60	80	4.4	-	8.7	-	5.5	-
40:1	38	50	75	100	3.8	-	7.7	-	4.9	-
30 1/2:1	49	66	98	131	3.3	-	6.5	-	4.1	-
25 1/2:1	59	78	118	157	2.9	-	5.8	-	3.7	-
20 1/2:1	73	98	146	195	2.5	-	5	-	3.2	-
15 1/3:1	98	130	196	261	2.1	-	4.1	-	2.6	-
12 1/3:1	122	162	243	324	1.8	-	3.5	-	2.2	-
9 1/4:1	162	216	324	432	1.4	-	2.8	-	1.8	-

PBL86-78 = 229
 PBL60-98 = 249
 PBL60-118 = 269
 PBL-138 = 289

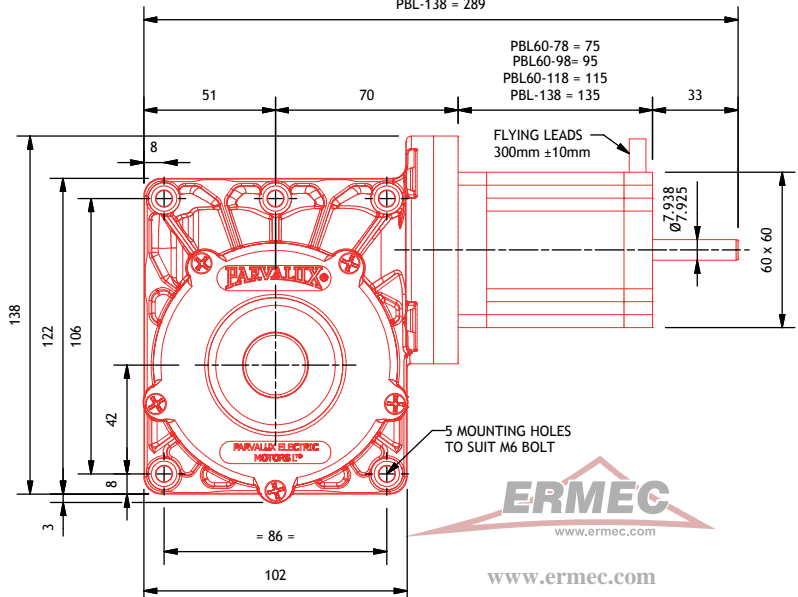
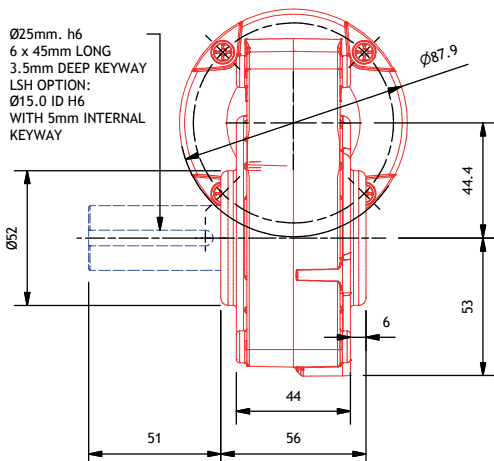

PBL60-138(IE)LS/LSH

MOTOR	Brushless DC motor
PROTECTION	IP54 (IP50 at exposed rear motor shaft)
GEARBOX	Worm and wheel
MOTOR POWER	69 - 184 Watts
SPEED*	25 - 432 rpm
VOLTAGE	24V DC (or 48V DC with IE model)
WEIGHT	2.7 kg
CONTROLLER	B (or integral with IE model)
SHAFT TYPE	Single ended as standard; hollow or double ended upon request
EXTRAS	See page 18



PBL60-138LS pictured

See page 61 to specify shaft and gearbox position

*input speed variable up to 4000 rpm; other ratios available on request

Ratio	Final speed (rpm)				Rated torque Nm up to 4000 rpm		Peak torque Nm up to 2500 rpm		15 min rating Nm up to 3500 rpm	
	1500 rpm 69 W	2000 rpm 92 W	3000 rpm 138 W	4000 rpm 184 W	Composite	Bronze	Composite	Bronze	Composite	Bronze
60:1	25	33	50*	67*	9.6	9.6	11.3	17	11.3	12
50:1	30	40	60*	80*	8.7	8.7	11.3	17	10.9	10.9
40:1	38	50	75*	100*	7.7	7.7	14.6	15.3	9.6	9.6
30 1/2:1	49	66	98*	131*	6.5	-	13	-	8.1	-
25 1/2:1	59	78	118*	157*	5.8	-	11.6	-	7.3	-
20 1/2:1	73	98	146*	195*	5	-	10	-	6.3	-
15 1/3:1	98	130	196	261*	4.1	-	8.2	-	5.1	-
12 1/3:1	122	162	243	324*	3.5	-	7	-	4.4	-
9 1/4:1	162	216	324	432	2.8	-	5.7	-	3.6	-

* Please refer to the information regarding thermal rating on page 64 for these combinations of motor speed and gear ratio

PBL86-78 = 229
 PBL60-98 = 249
 PBL60-118 = 269
 PBL-138 = 289

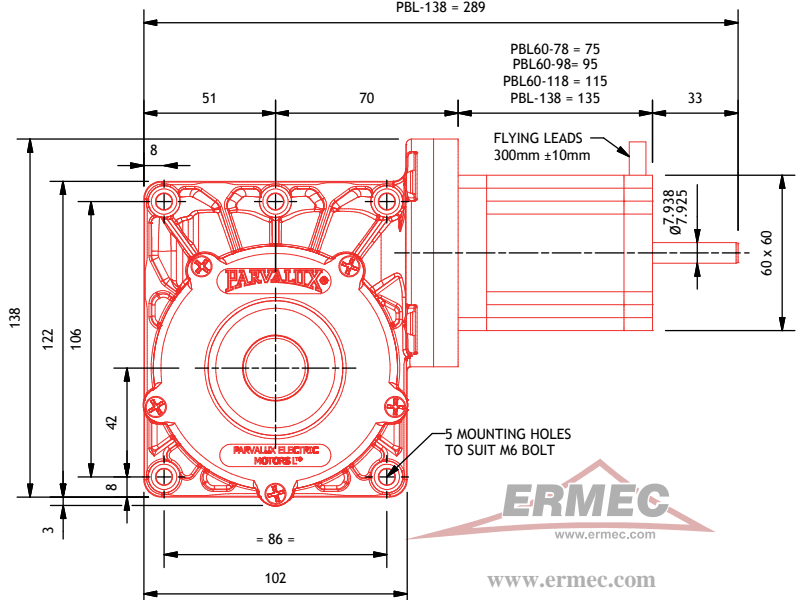
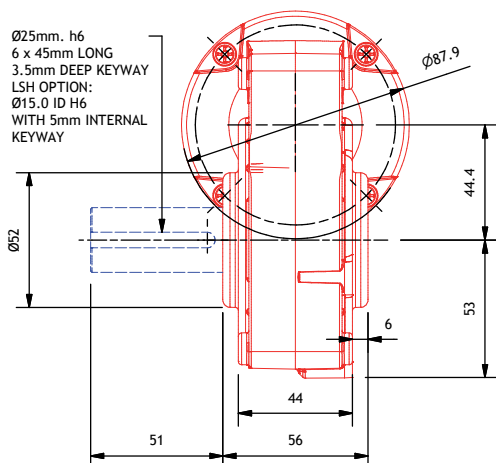

PBL86-91LS/LSH

PARVALUX®

MOTOR	Brushless DC motor
PROTECTION	IP54 (IP50 at exposed rear motor shaft)
GEARBOX	Worm and wheel (LS)
MOTOR POWER	110 - 220 Watts
SPEED*	25 - 324 rpm
VOLTAGE	48V DC
WEIGHT	3.3 kg
CONTROLLER	B
SHAFT TYPE	Single ended as standard; hollow or double ended upon request
EXTRAS	See page 18



PBL86-91LS pictured

See page 61 to specify shaft and gearbox position

*input speed variable up to 4000 rpm; other ratios available on request

Ratio	Final speed (rpm)			Rated torque Nm up to 3000 rpm		Peak torque Nm up to 3000 rpm		15min rating Nm up to 3000 rpm	
	1500 rpm 110 W	2000 rpm 147 W	3000 rpm 220 W	Composite	Bronze	Composite	Bronze	Composite	Bronze
60:1	25	33*	50*	11.3	15.2	11.3	17	11.3	17
50:1	30	40*	60*	11.3	13.9	11.3	17	11.3	15.8
40:1	38*	50*	75*	12.2	12.2	14.6	17.4	14	14
30 1/2:1	49	66*	98*	10.4	10.2	14.6	14.8	11.8	11.8
25 1/2:1	59	78*	118*	9.2	-	13.2	-	10.5	-
20 1/2:1	73	98*	146*	8	-	11.4	-	9.1	-
15 1/3:1	98	130	196*	6.5	-	9.3	-	7.5	-
12 1/3:1	122	162	243*	5.6	-	8	-	6.4	-
9 1/4:1	162	216	324*	4.5	-	6.5	-	5.2	-

* Please refer to the information regarding thermal rating on page 64 for these combinations of motor speed and gear ratio

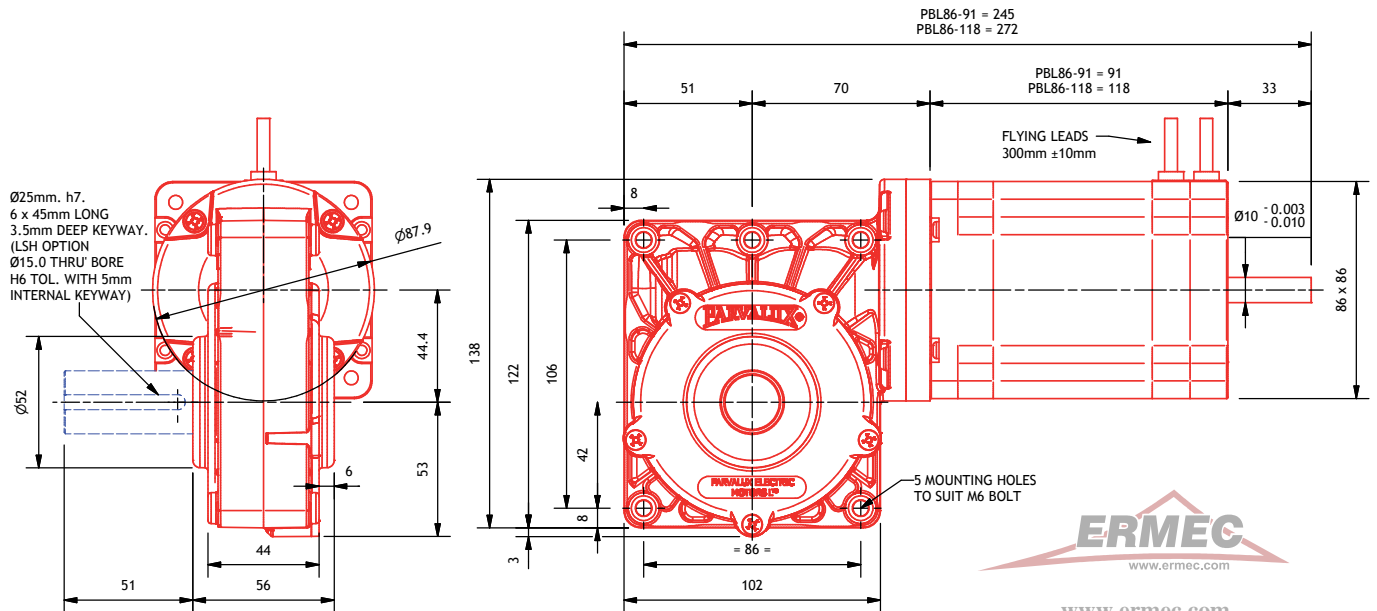

PBL86-118LS/LSH

MOTOR	Brushless DC motor
PROTECTION	IP54 (IP50 at exposed rear motor shaft)
GEARBOX	Worm and wheel (LS)
MOTOR POWER	173 - 346 Watts
SPEED*	25 - 324 rpm
VOLTAGE	48V DC
WEIGHT	4.3 kg
CONTROLLER	50B
SHAFT TYPE	Single ended as standard; hollow or double ended upon request
EXTRAS	See page 18



PBL86-118LS pictured

See page 61 to specify shaft and gearbox position

*input speed variable up to 4000 rpm; other ratios available on request

Ratio	Final speed (rpm)			Rated torque Nm up to 3000 rpm		Peak torque Nm up to 3000 rpm		15min rating Nm up to 3000 rpm	
	1500 rpm 173 W	2000 rpm 230 W	3000 rpm 346 W	Composite	Bronze	Composite	Bronze	Composite	Bronze
60:1	25	33*	50*	11.3	17	11.3	17	11.3	17
50:1	30	40*	60*	11.3	17	11.3	17	11.3	17
40:1	38*	50*	75*	14.6	19.2	14.6	22	14.6	22
30 1/2:1	49*	66*	98*	14.6	16.3	14.6	22	14.6	22
25 1/2:1	59*	78*	118*	14.5	14.5	14.6	22	14.6	19.8
20 1/2:1	73*	98*	146*	12.5	12.5	14.6	22	14.6	17.1
15 1/3:1	98*	130*	196*	10.3	10.3	14.6	21	14	14
12 1/3:1	122*	162*	243*	8.8	8.8	14.6	17.6	12	12
9 1/4:1	162	216*	324*	7.1	-	14.2	-	9.7	-

* Please refer to the information regarding thermal rating on page 64 for these combinations of motor speed and gear ratio

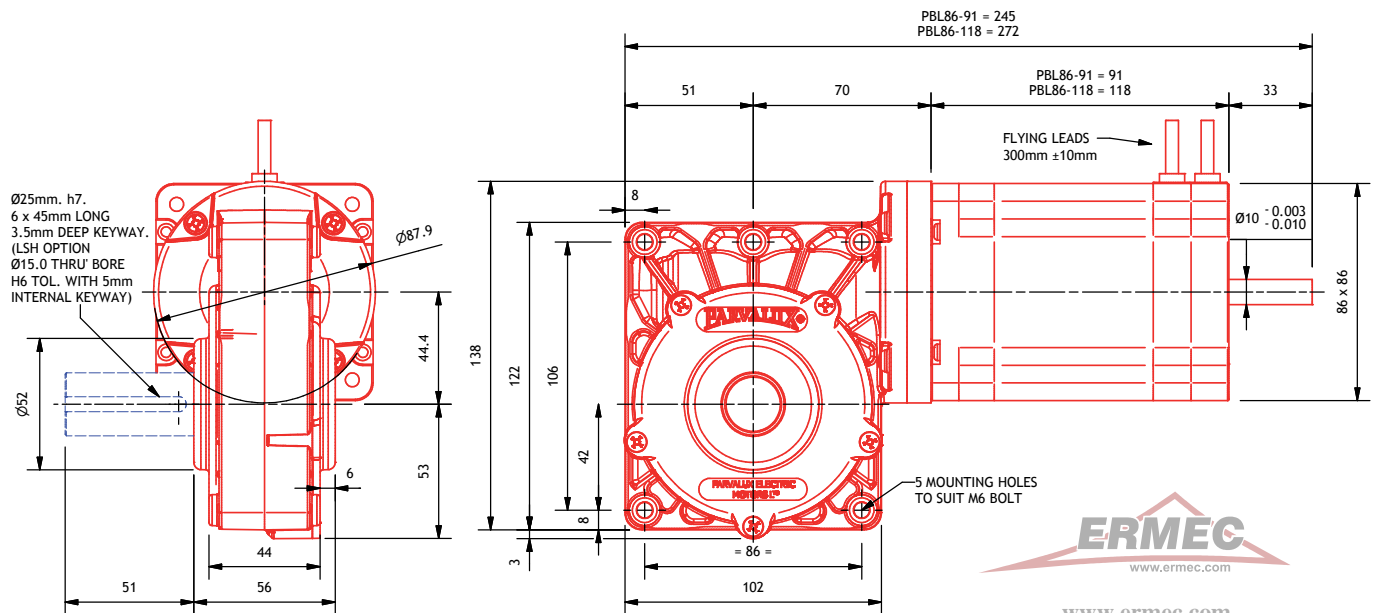

PBL86-91G/GH

PARVALUX®

MOTOR	Brushless DC motor
PROTECTION	IP54 (IP50 at exposed rear motor shaft)
GEARBOX	Worm and wheel (G)
MOTOR POWER	110 - 220 Watts
SPEED*	20 - 240 rpm
VOLTAGE	48V DC
WEIGHT	4.9 kg
CONTROLLER	B
SHAFT TYPE	Single ended as standard; hollow or double ended upon request
EXTRAS	See page 18



PBL86-91G pictured

See page 61 to specify shaft and gearbox position

*input speed variable up to 4000 rpm; other ratios available on request

Ratio	Final speed (rpm)			Rated torque Nm up to 3000 rpm	Peak torque Nm up to 3000 rpm	15min rating Nm up to 3000 rpm
	1500 rpm 110 W	2000 rpm 147 W	3000 rpm 220 W	Composite	Composite	Composite
75:1	20	27	40	29	42	34
60:1	25	33	50	24	35	28
50:1	30	40	60	21	31	24
30:1	50	67	100	13.9	19.8	15.8
25:1	60	80	120	12.1	17.3	13.8
12 1/2:1	120	160	240	6.6	9.4	7.5

PBL86-91 = 276
PBL86-118 = 303
PBL86-145 = 330

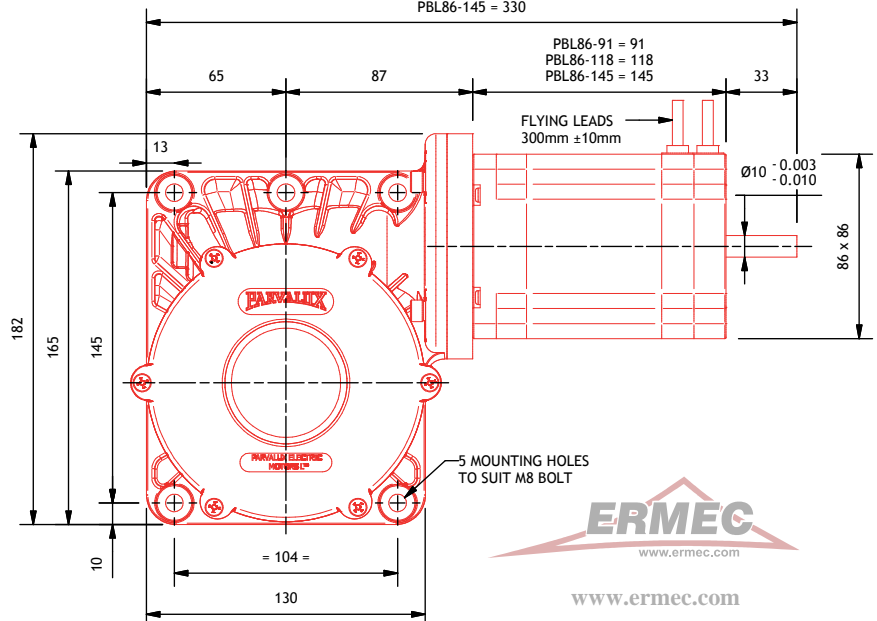
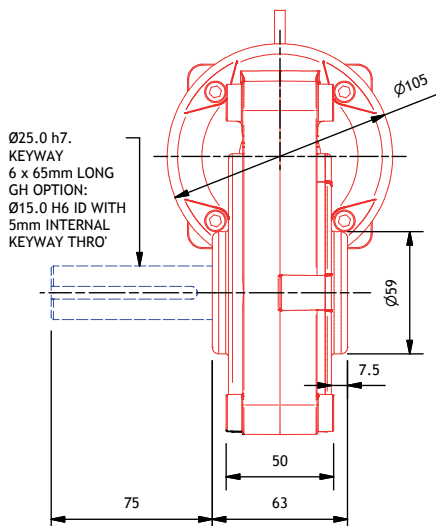

PBL86-118G/GH

MOTOR	Brushless DC motor
PROTECTION	IP54 (IP50 at exposed rear motor shaft)
GEARBOX	Worm and wheel (G)
MOTOR POWER	173 - 346 Watts
SPEED*	20 - 240 rpm
VOLTAGE	48V DC
WEIGHT	5.9 kg
CONTROLLER	50B
SHAFT TYPE	Single ended as standard; hollow or double ended upon request
EXTRAS	See page 18



PBL86-118G pictured

See page 61 to specify shaft and gearbox position

*input speed variable up to 4000 rpm; other ratios available on request

Ratio	Final speed (rpm)			Rated torque Nm up to 3000 rpm	Peak torque Nm up to 3000 rpm	15min rating Nm up to 3000 rpm
	1500 rpm 173 Watts	2000 rpm 230 Watts	3000 rpm 346 Watts			
75:1	20	27*	40*	46	50	50
60:1	25	33	50*	38	50	50
50:1	30	40	60*	34	50	46
30:1	50	67	100*	22	44	30
25:1	60	80	120*	19	38	26
12 1/2:1	120	160	240	10.3	21	14.1

* Please refer to the information regarding thermal rating on page 64 for these combinations of motor speed and gear ratio

PBL86-91 = 276
PBL86-118 = 303
PBL86-145 = 330

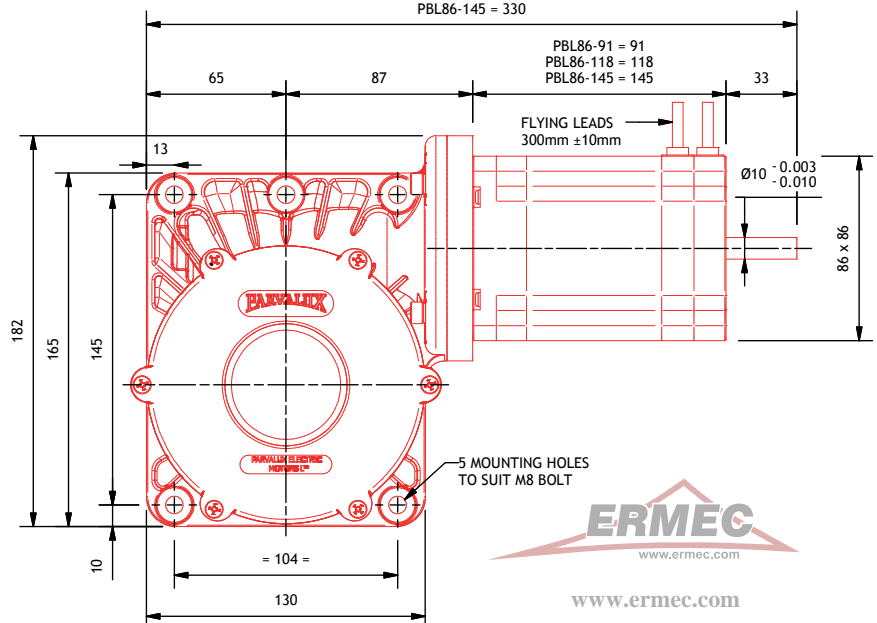
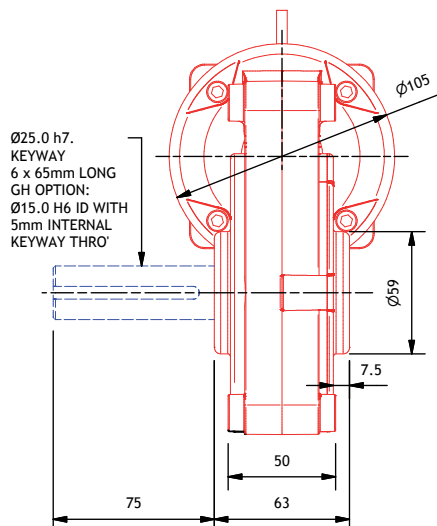

PBL86-145G/GH

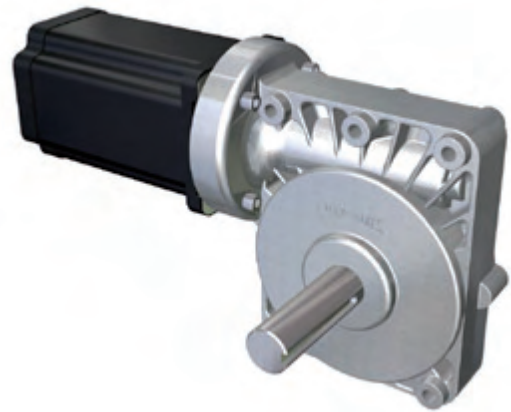

MOTOR	Brushless DC motor
PROTECTION	IP54 (IP50 at exposed rear motor shaft)
GEARBOX	Worm and wheel (G)
MOTOR POWER	220 - 440 Watts
SPEED*	20 - 240 rpm
VOLTAGE	48V DC
WEIGHT	6.9 kg
CONTROLLER	50B
SHAFT TYPE	Single ended as standard; hollow or double ended upon request
EXTRAS	See page 18

PBL86-145G pictured

See page 61 to specify shaft and gearbox position

*input speed variable up to 4000 rpm; other ratios available on request

Ratio	Final speed (rpm)			Rated torque Nm up to 3000 rpm	Peak torque Nm up to 3000 rpm	15min rating Nm up to 3000 rpm
	1500 rpm 220 W	2000 rpm 293 W	3000 rpm 440 W			
75:1	20	27*	40*	Composite	Composite	Composite
60:1	25	33*	50*	49	50	50
50:1	30	40*	60*	43	50	50
30:1	50	67*	100*	28	50	42
25:1	60	80	120*	24	48	36
12 1/2:1	120	160	240*	13.1	26	19.7

* Please refer to the information regarding thermal rating on page 64 for these combinations of motor speed and gear ratio

PBL86-91 = 276
PBL86-118 = 303
PBL86-145 = 330

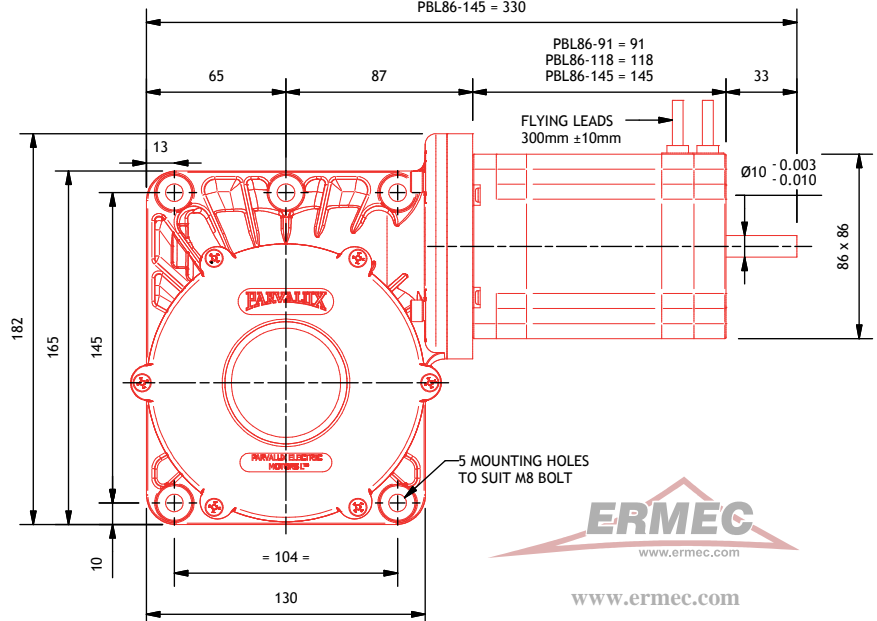
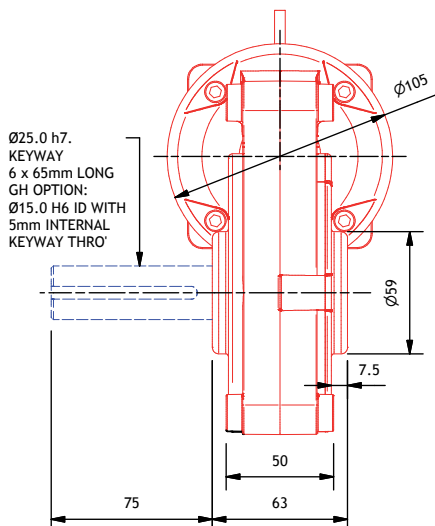

www.ermec.com

PBL60-78SIW

MOTOR	Brushless DC motor
PROTECTION	IP54 (IP50 at exposed rear motor shaft)
GEARBOX	In-line worm (SIW)
MOTOR POWER	17 - 46 Watts
SPEED*	1.1 - 102 rpm
VOLTAGE	24V DC
WEIGHT	1.7 kg
CONTROLLER	N
SHAFT TYPE	Single ended shaft
EXTRAS	See page 18



*input speed variable up to 4000 rpm; other ratios available on request

See page 61 to specify shaft and gearbox position

Ratio		Final speed (rpm)				Rated torque Nm up to 4000 rpm		Peak torque Nm up to 2500 rpm		15 min rating Nm up to 3500 rpm	
		1500 rpm 17 W	2000 rpm 23 W	3000 rpm 35 W	4000 rpm 46 W	Composite	Bronze	Composite	Bronze	Composite	Bronze
54:1	25:1	1.1	1.5	2.2	3	7	11.3	7	11.3	7	11.3
27:1	25:1	2.2	3	4.4	5.9	7	11.3	7	11.3	7	11.3
14 1/2:1	25:1	4.1	5.5	8.3	11	7	11.3	7	11.3	7	11.3
8 1/3:1	25:1	7.2	9.6	14.4	19.2	7	8.6	7	11.3	7	10.9
16 1/2:1	8 1/3:1	10.9	14.5	22	29	6.5	6.5	7	11.3	7	8.2
12 1/2:1	8 1/3:1	14.4	19.2	29	38	5.3	5.3	7	10.6	6.8	6.8
10 1/3:1	8 1/3:1	17.4	23	35	46	4.6	4.6	7	9.2	5.9	5.9
9 1/3:1	8 1/3:1	19.3	26	39	51	4.3	4.3	7	8.6	5.5	5.5
8 1/3:1	8 1/3:1	22	29	43	58	3.9	3.9	7	7.9	5	5
7 1/4:1	8 1/3:1	25	33	50	66	3.5	3.5	7	7.1	4.5	4.5
6 1/4:1	8 1/3:1	29	38	58	77	3.2	-	6.3	-	4	-
6 1/4:1	6 1/4:1	38	51	77	102	2.5	-	5.1	-	3.2	-

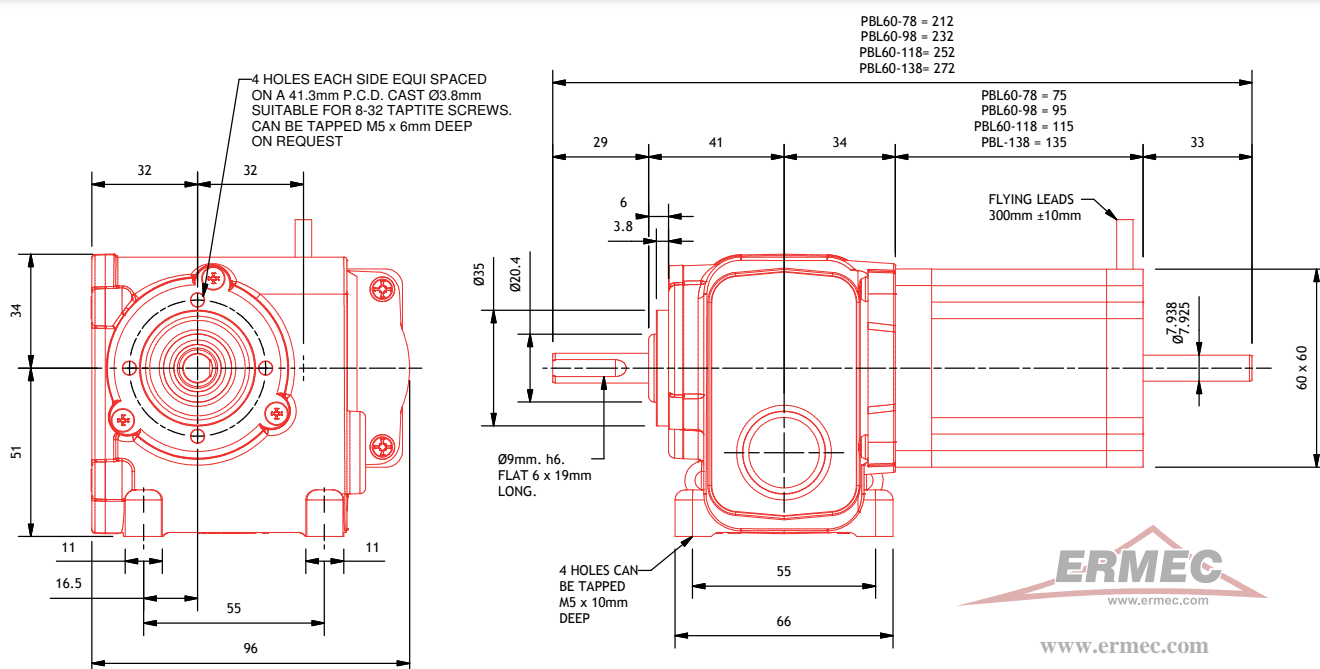

PBL60-98(IE)SIW

MOTOR	Brushless DC motor
PROTECTION	IP54 (IP50 at exposed rear motor shaft)
GEARBOX	In-line worm (SIW)
MOTOR POWER	35 - 92 Watts
SPEED*	1.1 - 102 rpm
VOLTAGE	24V DC
WEIGHT	2.0 kg
CONTROLLER	N (or integral with IE model)
SHAFT TYPE	Single ended shaft
EXTRAS	See page 18



PBL60-98SIW pictured

See page 61 to specify shaft and gearbox position

*input speed variable up to 4000 rpm; other ratios available on request

Ratio		Final speed (rpm)				Rated torque Nm up to 4000 rpm		Peak torque Nm up to 2500 rpm		15 min rating Nm up to 3500 rpm	
		1500 rpm 35 W	2000 rpm 46 W	3000 rpm 69 W	4000 rpm 92 W	Composite	Bronze	Composite	Bronze	Composite	Bronze
54:1	25:1	1.1	1.5	2.2	3	7	11.3	7	11.3	7	11.3
27:1	25:1	2.2	3	4.4	5.9	7	11.3	7	11.3	7	11.3
14 1/2:1	25:1	4.1	5.5	8.3	11	7	11.3	7	11.3	7	11.3
8 1/3:1	25:1	7.2	9.6	14.4	19.2	7	11.3	7	11.3	7	11.3
16 1/2:1	8 1/3:1	10.9	14.5	22	29	7	11.3	7	11.3	7	11.3
12 1/2:1	8 1/3:1	14.4	19.2	29	38	7	10.6	7	11.3	7	11.3
10 1/3:1	8 1/3:1	17.4	23	35	46	7	9.2	7	11.3	7	11.3
9 1/3:1	8 1/3:1	19.3	26	39	51	7	8.6	7	11.3	7	10.9
8 1/3:1	8 1/3:1	22	29	43	58	7	7.9	7	11.3	7	10
7 1/4:1	8 1/3:1	25	33	50	66	7	7.1	7	11.3	7	9
6 1/4:1	8 1/3:1	29	38	58	77	6.3	6.3	7	11.3	7	8.1
6 1/4:1	6 1/4:1	38	51	77	102	5.1	5.1	7	10.2	6.5	6.5

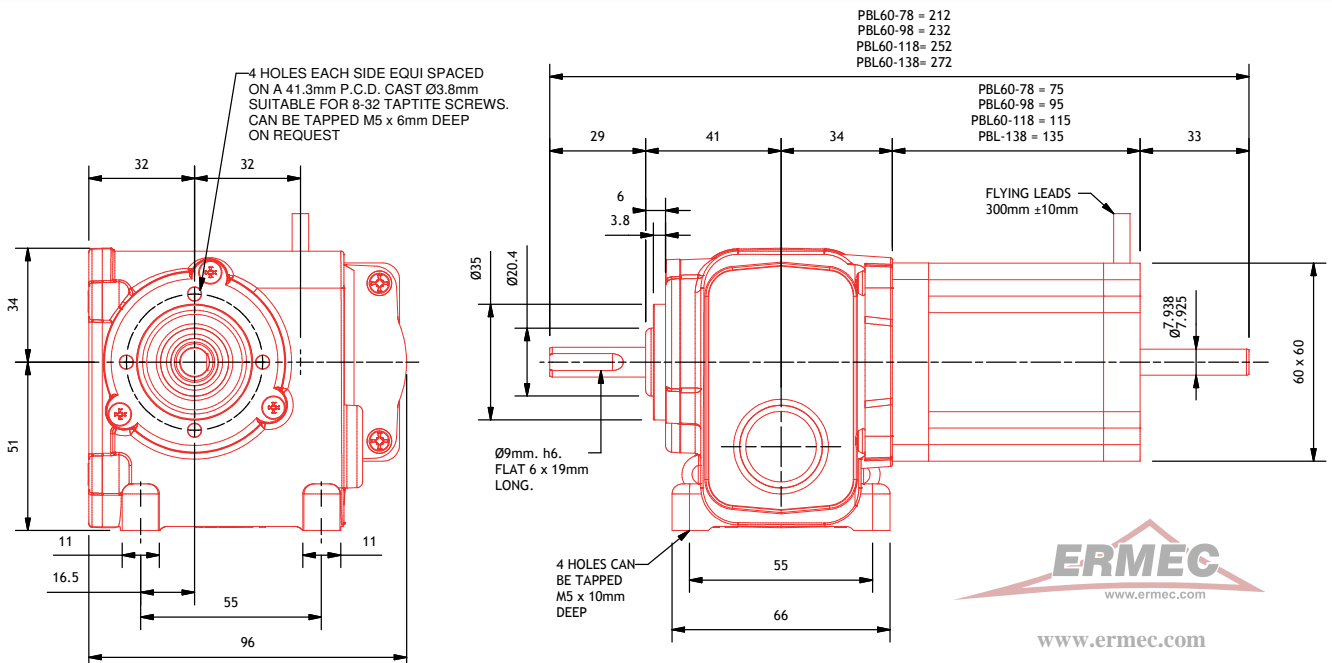

PBL60-118(IE)SIW

MOTOR	Brushless DC motor
PROTECTION	IP54 (IP50 at exposed rear motor shaft)
GEARBOX	IN-line worm (SIW)
MOTOR POWER	50 - 134 Watts
SPEED*	1.1 - 102 rpm
VOLTAGE	24V DC
WEIGHT	2.3 kg
CONTROLLER	B (or integral with IE model)
SHAFT TYPE	Single ended shaft
EXTRAS	See page 18

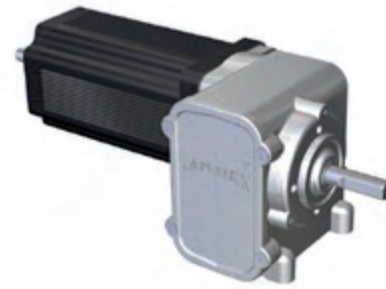

PBL60-118SIW pictured

See page 61 to specify shaft and gearbox position

*input speed variable up to 4000 rpm; other ratios available on request

Ratio		Final speed (rpm)				Rated torque Nm up to 4000 rpm		Peak torque Nm up to 2500 rpm		15 min rating Nm up to 3500 rpm	
		1500 rpm 50 W	2000 rpm 67 W	3000 rpm 101 W	4000 rpm 134 W	Composite	Bronze	Composite	Bronze	Composite	Bronze
54:1	25:1	1.1	1.5	2.2	3	7	11.3	7	11.3	7	11.3
27:1	25:1	2.2	3	4.4	5.9	7	11.3	7	11.3	7	11.3
14 1/2:1	25:1	4.1	5.5	8.3	11	7	11.3	7	11.3	7	11.3
8 1/3:1	25:1	7.2	9.6	14.4	19.2	7	11.3	7	11.3	7	11.3
16 1/2:1	8 1/3:1	10.9	14.5	22	29	7	11.3	7	11.3	7	11.3
12 1/2:1	8 1/3:1	14.4	19.2	29	38	7	11.3	7	11.3	7	11.3
10 1/3:1	8 1/3:1	17.4	23	35	46	7	11.3	7	11.3	7	11.3
9 1/3:1	8 1/3:1	19.3	26	39	51	7	11.3	7	11.3	7	11.3
8 1/3:1	8 1/3:1	22	29	43	58	7	11.3	7	11.3	7	11.3
7 1/4:1	8 1/3:1	25	33	50	66	7	10.3	7	11.3	7	11.3
6 1/4:1	8 1/3:1	29	38	58	77	7	9.2	7	11.3	7	11.3
6 1/4:1	6 1/4:1	38	51	77	102	7	7.4	7	11.3	7	9.3

PBL60-78 = 212
 PBL60-98 = 232
 PBL60-118 = 252
 PBL60-138 = 272

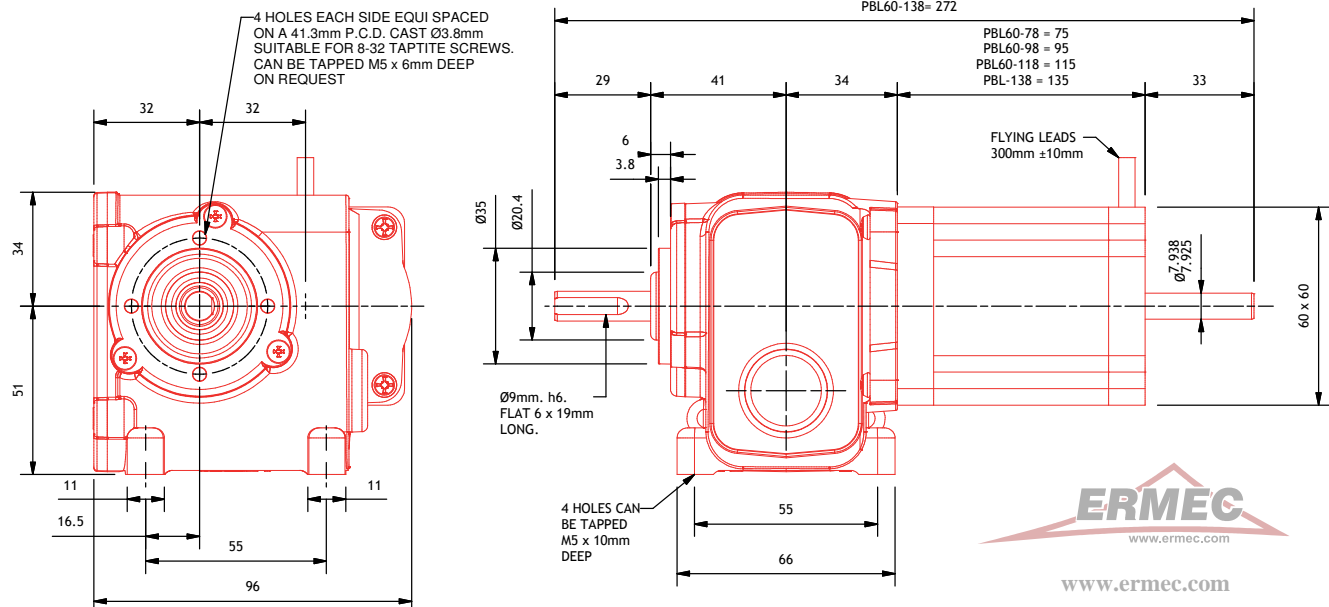

PBL60-78MIW

MOTOR	Brushless DC motor
PROTECTION	IP54 (IP50 at exposed rear motor shaft)
GEARBOX	In-line worm (MIW)
MOTOR POWER	17 - 46 Watts
SPEED*	1.1 - 77 rpm
VOLTAGE	24V DC
WEIGHT	2.5 kg
CONTROLLER	N
SHAFT TYPE	Single ended shaft
EXTRAS	See page 18



*input speed variable up to 4000 rpm; other ratios available on request

See page 61 to specify shaft and gearbox position

Ratio		Final speed (rpm)				Rated torque Nm up to 4000 rpm		Peak torque Nm up to 2500 rpm		15 min rating Nm up to 3500 rpm	
		1500 rpm 17 W	2000 rpm 23 W	3000 rpm 35 W	4000 rpm 46 W	Composite	Bronze	Composite	Bronze	Composite	Bronze
54:1	25:1	1.1	1.5	2.2	3	17	28	17	28	17	28
27:1	25:1	2.2	3	4.4	5.9	17	19.6	17	28	17	25
14 1/2:1	25:1	4.1	5.5	8.3	11	12.8	12.8	17	26	16.3	16.3
8 1/3:1	25:1	7.2	9.6	14.4	19.2	8.6	8.6	17	17.1	10.9	10.9
16 1/2:1	8 1/3:1	10.9	14.5	22	29	6.5	-	12.9	-	8.2	-
12 1/2:1	8 1/3:1	14.4	19.2	29	38	5.3	-	10.6	-	6.8	-
10 1/3:1	8 1/3:1	17.4	23	35	46	4.6	-	9.2	-	5.9	-
9 1/3:1	8 1/3:1	19.3	26	39	51	4.3	-	8.6	-	5.5	-
8 1/3:1	8 1/3:1	22	29	43	58	3.9	-	7.9	-	5	-
7 1/4:1	8 1/3:1	25	33	50	66	3.5	-	7.1	-	4.5	-
6 1/4:1	8 1/3:1	29	38	58	77	3.2	-	6.3	-	4	-

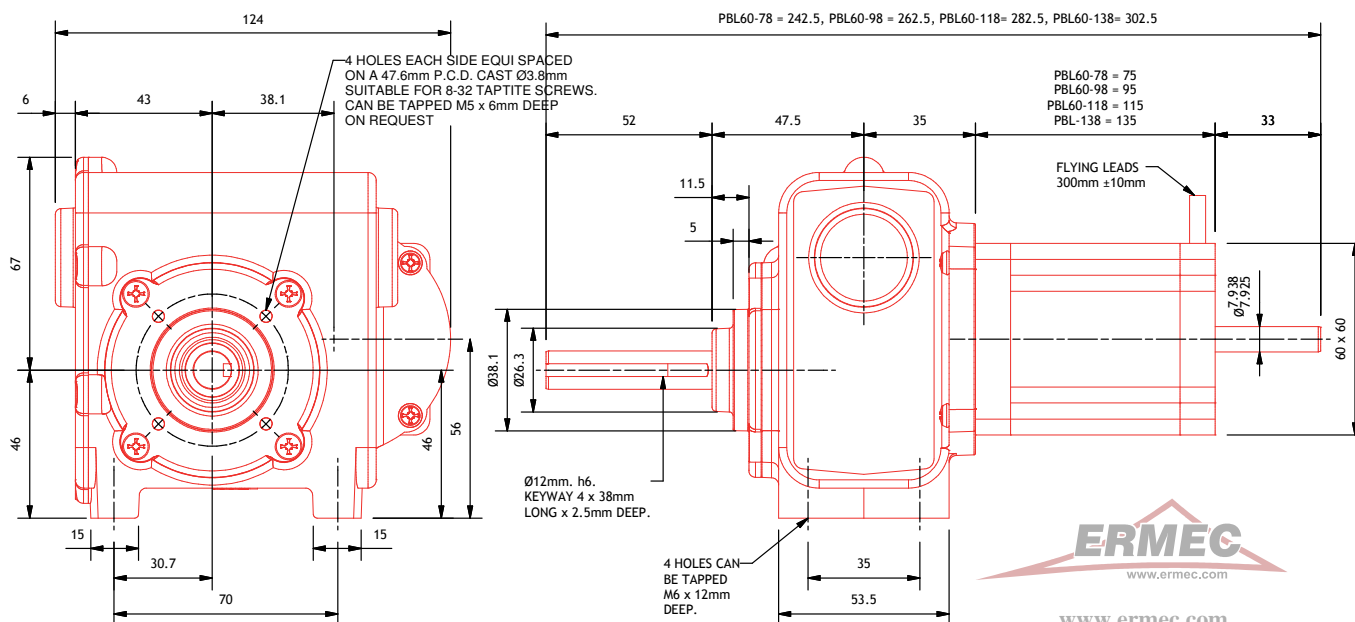

PBL60-98(IE)MIW

MOTOR	Brushless DC motor
PROTECTION	IP54 (IP50 at exposed rear motor shaft)
GEARBOX	In-line worm (MIW)
MOTOR POWER	35 - 92 Watts
SPEED*	1.1 - 77 rpm
VOLTAGE	24V DC
WEIGHT	2.8 kg
CONTROLLER	N (or integral with IE model)
SHAFT TYPE	Single ended shaft
EXTRAS	See page 18



PBL60-98MIW pictured

See page 61 to specify shaft and gearbox position

*input speed variable up to 4000 rpm; other ratios available on request

Ratio		Final speed (rpm)				Rated torque Nm up to 4000 rpm		Peak torque Nm up to 2500 rpm		15 min rating Nm up to 3500 rpm	
		1500 rpm 35 W	2000 rpm 46 W	3000 rpm 69 W	4000 rpm 92 W	Composite	Bronze	Composite	Bronze	Composite	Bronze
54:1	25:1	1.1	1.5	2.2	3	17	28	17	28	17	28
27:1	25:1	2.2	3	4.4	5.9	17	28	17	28	17	28
14 1/2:1	25:1	4.1	5.5	8.3	11	17	26	17	28	17	28
8 1/3:1	25:1	7.2	9.6	14.4	19.2	17	17.1	17	28	17	22
16 1/2:1	8 1/3:1	10.9	14.5	22	29	12.9	12.9	17	26	16.5	16.5
12 1/2:1	8 1/3:1	14.4	19.2	29	38	10.6	10.6	17	21	13.5	13.5
10 1/3:1	8 1/3:1	17.4	23	35	46	9.2	9.2	17	18.5	11.8	11.8
9 1/3:1	8 1/3:1	19.3	26	39	51	8.6	8.6	17	17.2	10.9	10.9
8 1/3:1	8 1/3:1	22	29	43	58	7.9	-	15.8	-	10	-
7 1/4:1	8 1/3:1	25	33	50	66	7.1	-	14.2	-	9	-
6 1/4:1	8 1/3:1	29	38	58	77	6.3	-	12.7	-	8.1	-

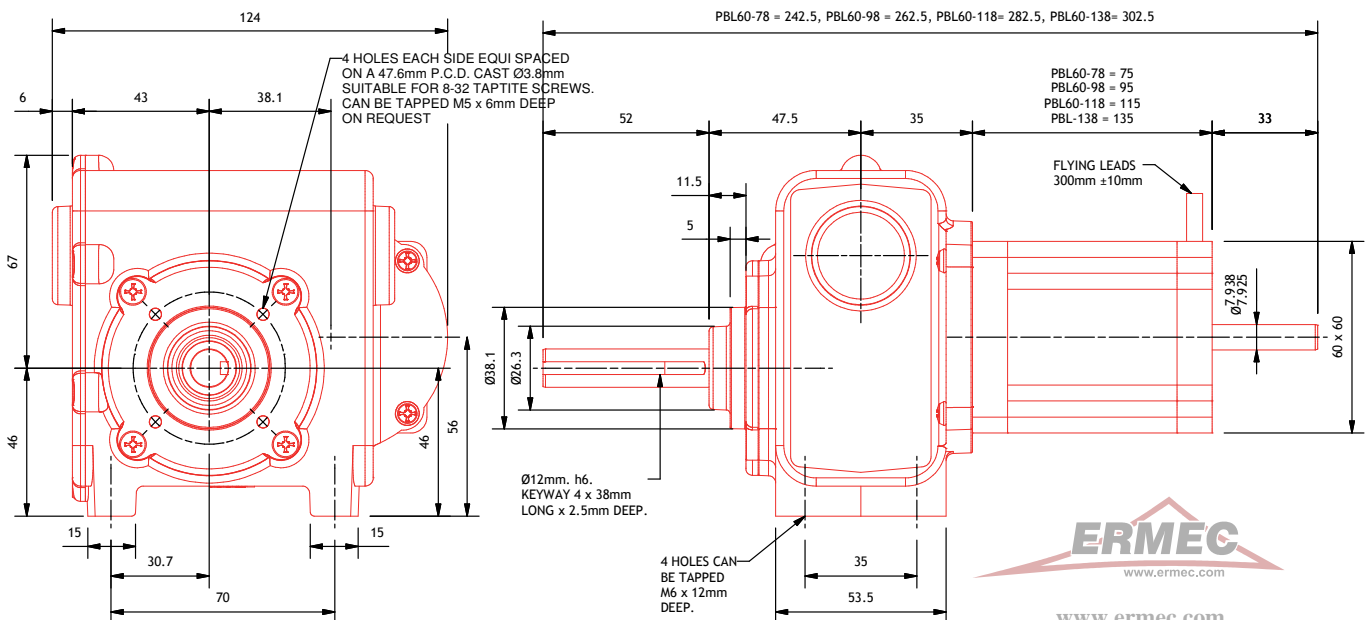

PBL60-118(IE)MIW

MOTOR Brushless DC motor
 PROTECTION IP54 (IP50 at exposed rear motor shaft)
 GEARBOX In-line worm (MIW)
 MOTOR POWER 50 - 134 Watts
 SPEED* 1.1 - 77 rpm
 VOLTAGE 24V DC
 WEIGHT 3.1 kg
 CONTROLLER B (or integral with IE model)
 SHAFT TYPE Single ended shaft
 EXTRAS See page 18



PBL60-118MIW pictured

See page 61 to specify shaft and gearbox position

*input speed variable up to 4000 rpm; other ratios available on request

Ratio		Final speed (rpm)				Rated torque Nm up to 4000 rpm		Peak torque Nm up to 2500 rpm		15 min rating Nm up to 3500 rpm	
		1500 rpm 50 W	2000 rpm 67 W	3000 rpm 101 W	4000 rpm 134 W	Composite	Bronze	Composite	Bronze	Composite	Bronze
54:1	25:1	1.1	1.5	2.2	3	17	28	17	28	17	28
27:1	25:1	2.2	3	4.4	5.9	17	28	17	28	17	28
14 1/2:1	25:1	4.1	5.5	8.3	11	17	28	17	28	17	28
8 1/3:1	25:1	7.2	9.6	14.4	19.2	17	25	17	28	17	28
16 1/2:1	8 1/3:1	10.9	14.5	22	29	17	18.8	17	28	17	24
12 1/2:1	8 1/3:1	14.4	19.2	29	38	15.5	15.5	17	28	17	19.3
10 1/3:1	8 1/3:1	17.4	23	35	46	13.5	13.5	17	27	16.8	16.8
9 1/3:1	8 1/3:1	19.3	26	39	51	12.5	12.5	17	25	15.6	15.6
8 1/3:1	8 1/3:1	22	29	43	58	11.5	11.5	17	23	14.3	14.3
7 1/4:1	8 1/3:1	25	33	50	66	10.3	10.3	17	21	12.9	12.9
6 1/4:1	8 1/3:1	29	38	58	77	9.2	9.2	17	18.4	11.5	11.5

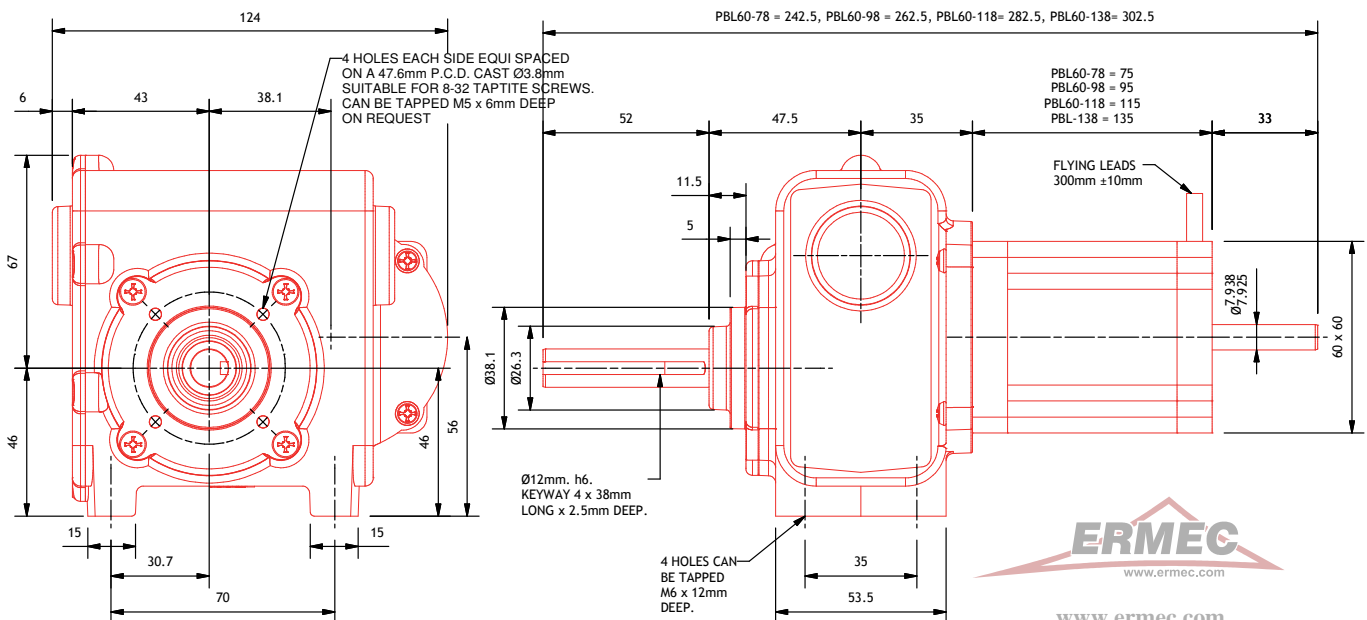

PBL60-138(IE)MIW

MOTOR	Brushless DC motor
PROTECTION	IP54 (IP50 at exposed rear motor shaft)
GEARBOX	In-line worm (MIW)
MOTOR POWER	69 - 184 Watts
SPEED*	1.1 - 77 rpm
VOLTAGE	24V DC (or 48V DC with IE model)
WEIGHT	3.4 kg
CONTROLLER	B (or integral with IE model)
SHAFT TYPE	Single ended shaft
EXTRAS	See page 18



*input speed variable up to 4000 rpm; other ratios available on request

See page 61 to specify shaft and gearbox position

Ratio		Final speed (rpm)				Rated torque Nm up to 4000 rpm		Peak torque Nm up to 2500 rpm		15 min rating Nm up to 3500 rpm	
		1500 rpm 69 W	2000 rpm 92 W	3000 rpm 138 W	4000 rpm 184 W	Composite	Bronze	Composite	Bronze	Composite	Bronze
54:1	25:1	1.1	1.5	2.2	3	17	28	17	28	17	28
27:1	25:1	2.2	3	4.4	5.9	17	28	17	28	17	28
14 1/2:1	25:1	4.1	5.5	8.3	11	17	28	17	28	17	28
8 1/3:1	25:1	7.2	9.6	14.4	19.2	17	28	17	28	17	28
16 1/2:1	8 1/3:1	10.9	14.5	22	29	17	26	17	28	17	28
12 1/2:1	8 1/3:1	14.4	19.2	29	38	17	21	17	28	17	27
10 1/3:1	8 1/3:1	17.4	23	35	46	17	18.5	17	28	17	23
9 1/3:1	8 1/3:1	19.3	26	39	51	17	17.2	17	28	17	21
8 1/3:1	8 1/3:1	22	29	43	58	15.8	15.8	17	28	17	19.7
7 1/4:1	8 1/3:1	25	33	50	66	14.2	14.2	17	28	17	17.7
6 1/4:1	8 1/3:1	29	38	58	77	12.7	12.7	17	25	15.8	15.8

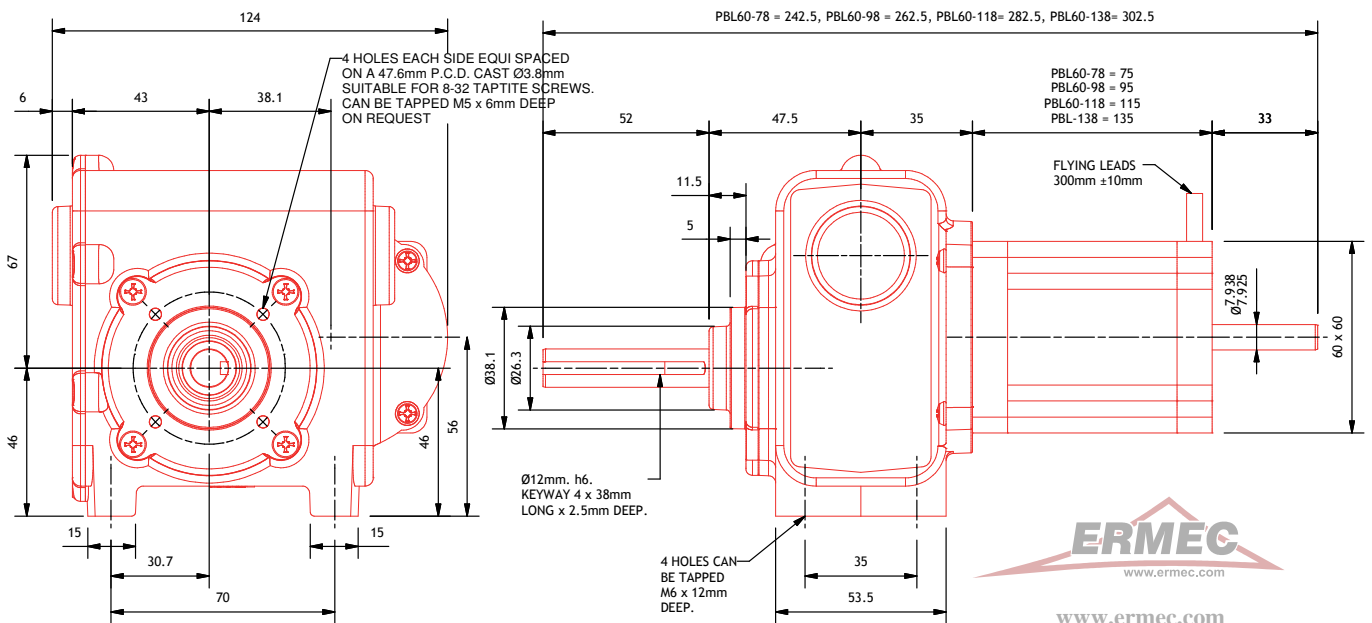

PBL42-47SWS

MOTOR	Brushless DC motor
PROTECTION	IP54 (IP50 at exposed rear motor shaft)
GEARBOX	Worm spur (SWS)
MOTOR POWER	10 - 26 Watts
SPEED*	1.1 - 67 rpm
VOLTAGE	24V DC
WEIGHT	1.2 kg
CONTROLLER	S
SHAFT TYPE	Single ended or double ended shaft as standard
EXTRAS	See page 18



*input speed variable up to 4000 rpm; other ratios available on request

See page 61 to specify shaft and gearbox position

Ratio		Final speed (rpm)				Rated torque Nm up to 4000 rpm	Peak torque Nm up to 2000 rpm	15 min rating Nm up to 3500 rpm
Worm	Spur	1500 rpm 10 W	2000 rpm 13 W	3000 rpm 20 W	4000 rpm 26 W			
44:1	31.3:1	1.1	1.5	2.2	2.9	11	11	11
22 1/2:1	31.3:1	2.1	2.8	4.3	5.7	11	11	11
12 1/2:1	31.3:1	3.8	5.1	7.7	10.2	11	11	11
9 1/3:1	31.3:1	5.1	6.8	10.3	13.7	11	11	11
9 1/3:1	23.5:1	6.8	9.1	13.7	18.2	8.5	11	10.6
6 1/4:1	23.5:1	10.2	13.6	20	27	6.3	11	7.9
12 1/2:1	9.6:1	12.5	16.7	25	33	4.5	9	5.6
9 1/3:1	9.6:1	16.7	22	33	45	3.6	7.3	4.5

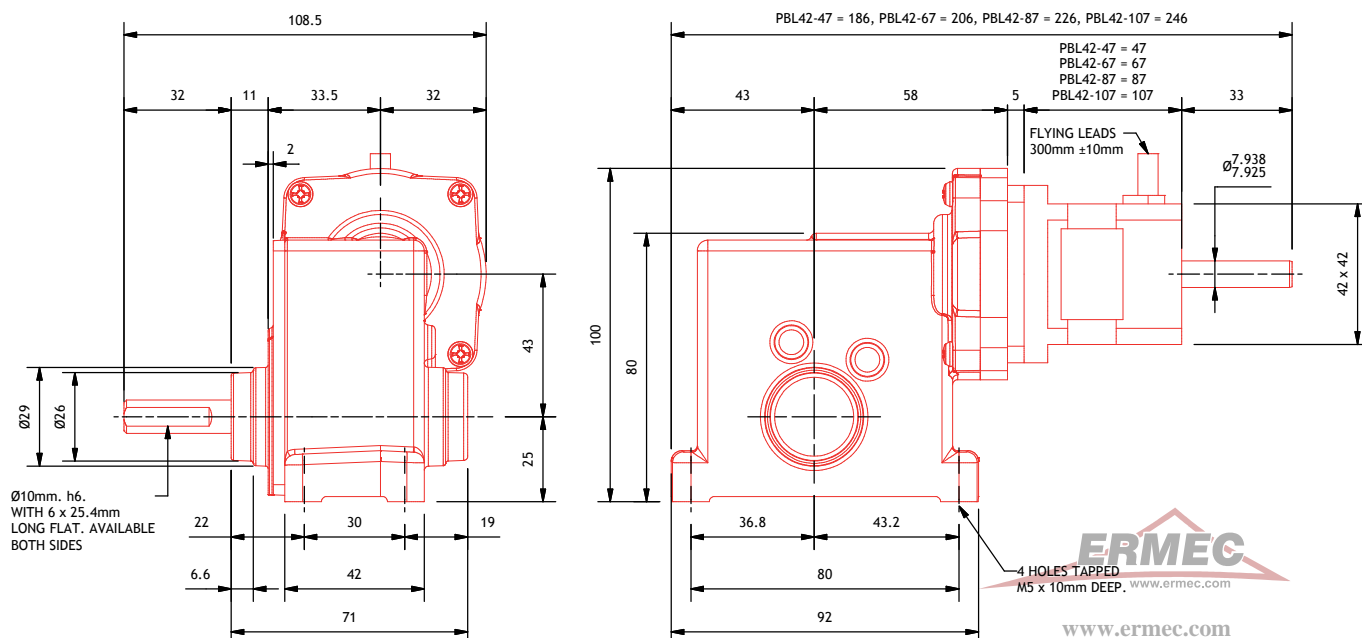

PBL42-67(IE)SWS

MOTOR Brushless DC motor
 PROTECTION IP54 (IP50 at exposed rear motor shaft)
 GEARBOX Worm spur (SWS)
 MOTOR POWER 20 - 52 Watts
 SPEED 1.1 - 67 rpm
 VOLTAGE 24V DC
 WEIGHT 1.4 kg
 CONTROLLER S (or integral with IE model)
 SHAFT TYPE Single ended or double ended shaft as standard
 EXTRAS See page 18



input speed variable up to 4000 rpm; other ratios available on request

See page 61 to specify shaft and gearbox position

Ratio		Final speed (rpm)				Rated torque Nm up to 4000 rpm	Peak torque Nm up to 2000 rpm	15 min rating Nm up to 3500 rpm
Worm	Spur	1500 rpm 20 W	2000 rpm 26 W	3000 rpm 39 W	4000 rpm 52 W			
44:1	31.3:1	1.1	1.5	2.2	2.9	11	11	11
22 1/2:1	31.3:1	2.1	2.8	4.3	5.7	11	11	11
12 1/2:1	31.3:1	3.8	5.1	7.7	10.2	11	11	11
9 1/3:1	31.3:1	5.1	6.8	10.3	13.7	11	11	11
9 1/3:1	23.5:1	6.8	9.1	13.7	18.2	11	11	11
6 1/4:1	23.5:1	10.2	13.6	20	27	11	11	11
12 1/2:1	9.6:1	12.5	16.7	25	33	9	11	11
9 1/3:1	9.6:1	16.7	22	33	45	7.3	11	9.3

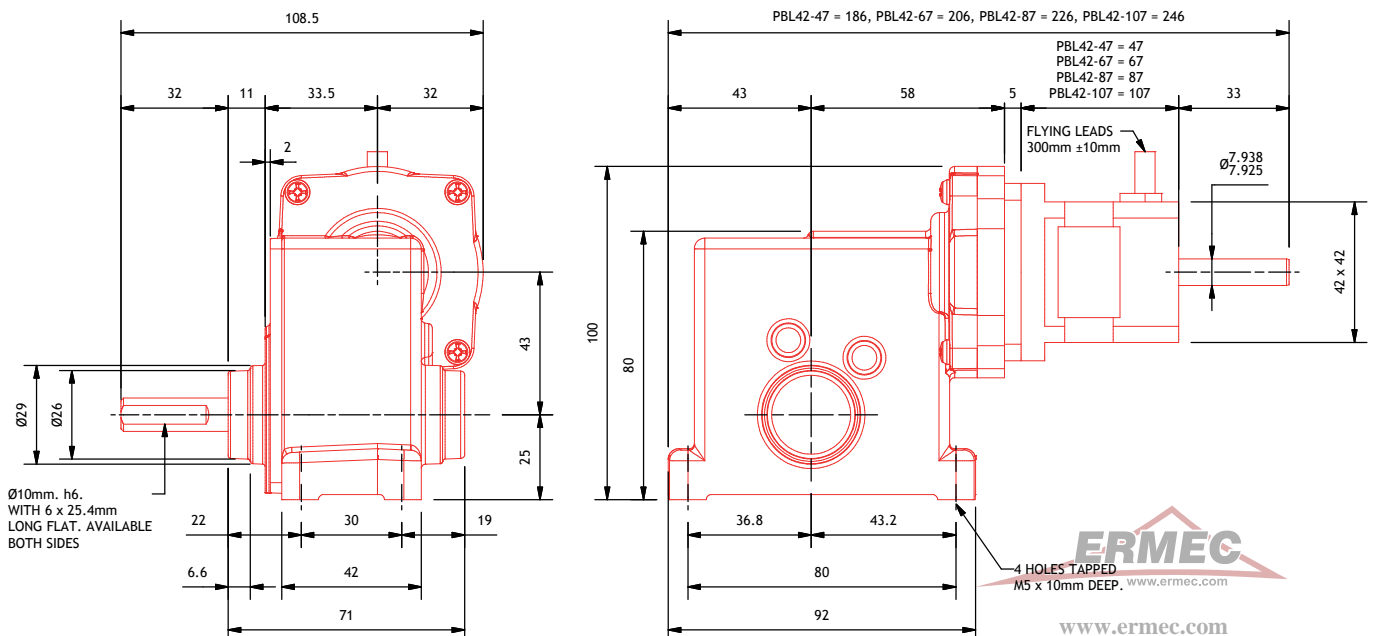

PBL60-78MWS

MOTOR	Brushless DC motor
PROTECTION	IP54 (IP50 at exposed rear motor shaft)
GEARBOX	Worm spur (MWS)
MOTOR POWER	17 - 46 Watts
SPEED*	1.1 - 98 rpm
VOLTAGE	24V DC
WEIGHT	3.5 kg
CONTROLLER	N
SHAFT TYPE	Single ended or double ended shaft as standard
EXTRAS	See page 18



*input speed variable up to 4000 rpm; other ratios available on request

See page 61 to specify shaft and gearbox position

Ratio		Final speed (rpm)				Rated torque Nm up to 4000 rpm	Peak torque Nm up to 2500 rpm	15 min rating Nm up to 3500 rpm
Worm	Spur	1500 rpm 17 W	2000 rpm 23 W	3000 rpm 35 W	4000 rpm 46 W			
40:1	35.39:1	1.1	1.4	2.1	2.8	45	45	45
27:1	35.39:1	1.6	2.1	3.1	4.2	45	45	45
18 1/2:1	35.39:1	2.3	3.1	4.6	6.1	37	45	45
12 1/2:1	35.39:1	3.4	4.5	6.8	9	28	45	36
9 1/3:1	35.39:1	4.5	6.1	9.1	12.1	23	45	29
7 1/4:1	35.39:1	5.8	7.8	11.7	15.6	18.9	38	24
8 1/3:1	15.1:1	11.9	15.9	24	32	9.2	18.5	11.8
7 1/4:1	15.1:1	13.7	18.3	27	37	8.3	16.7	10.6
6 1/4:1	15.1:1	15.9	21	32	42	7.4	14.9	9.5
8 1/3:1	6.5:1	28	37	55	74	4.1	8.1	5.2
7 1/4:1	6.5:1	32	42	64	85	3.7	7.3	4.7
6 1/4:1	6.5:1	37	49	74	98	3.3	6.5	4.2

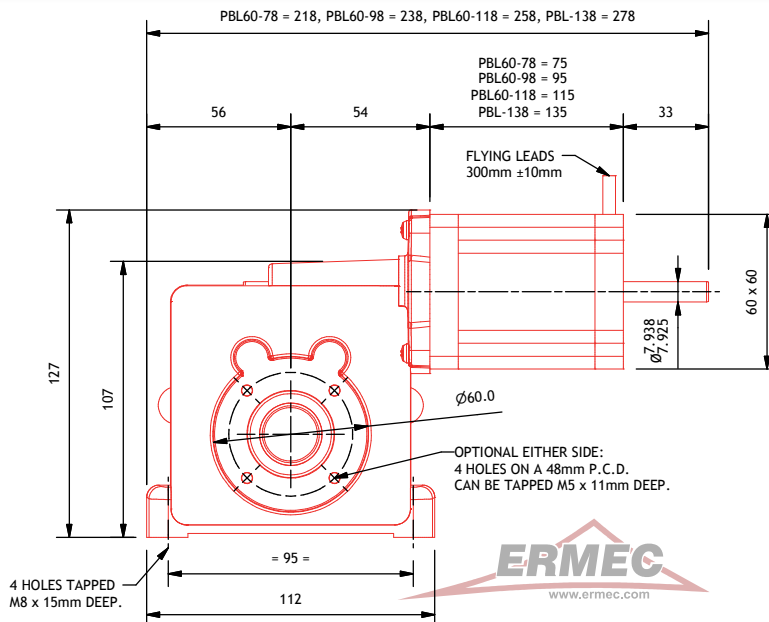
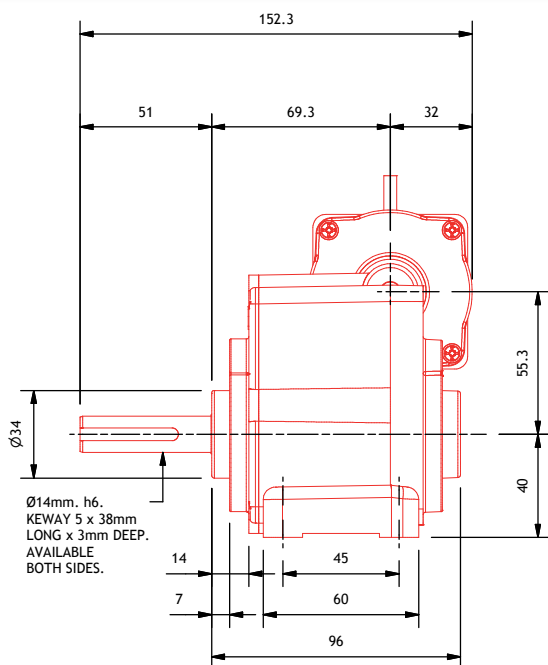

PBL60-98(IE)MWS

MOTOR	Brushless DC motor
PROTECTION	IP54 (IP50 at exposed rear motor shaft)
GEARBOX	Worm spur (MWS)
MOTOR POWER	35 - 92 Watts
SPEED*	1.1 - 98 rpm
VOLTAGE	24V DC
WEIGHT	3.8 kg
CONTROLLER	N (or integral with IE model)
SHAFT TYPE	Single ended or double ended shaft as standard
EXTRAS	See page 18



PBL60-98MWS pictured

See page 61 to specify shaft and gearbox position

*input speed variable up to 4000 rpm; other ratios available on request

Ratio		Final speed (rpm)				Rated torque Nm up to 4000 rpm	Peak torque Nm up to 2500 rpm	15 min rating Nm up to 3500 rpm
Worm	Spur	1500 rpm 35 W	2000 rpm 46 W	3000 rpm 69 W	4000 rpm 92 W			
40:1	35.39:1	1.1	1.4	2.1	2.8	45	45	45
27:1	35.39:1	1.6	2.1	3.1	4.2	45	45	45
18 1/2:1	35.39:1	2.3	3.1	4.6	6.1	45	45	45
12 1/2:1	35.39:1	3.4	4.5	6.8	9	45	45	45
9 1/3:1	35.39:1	4.5	6.1	9.1	12.1	45	45	45
7 1/4:1	35.39:1	5.8	7.8	11.7	15.6	38	45	45
8 1/3:1	15.1:1	11.9	15.9	24	32	18.5	22	22
7 1/4:1	15.1:1	13.7	18.3	27	37	16.7	22	21
6 1/4:1	15.1:1	15.9	21	32	42	14.9	22	18.9
8 1/3:1	6.5:1	28	37	55	74	8.1	9	9
7 1/4:1	6.5:1	32	42	64	85	7.3	9	9
6 1/4:1	6.5:1	37	49	74	98	6.5	9	8.3

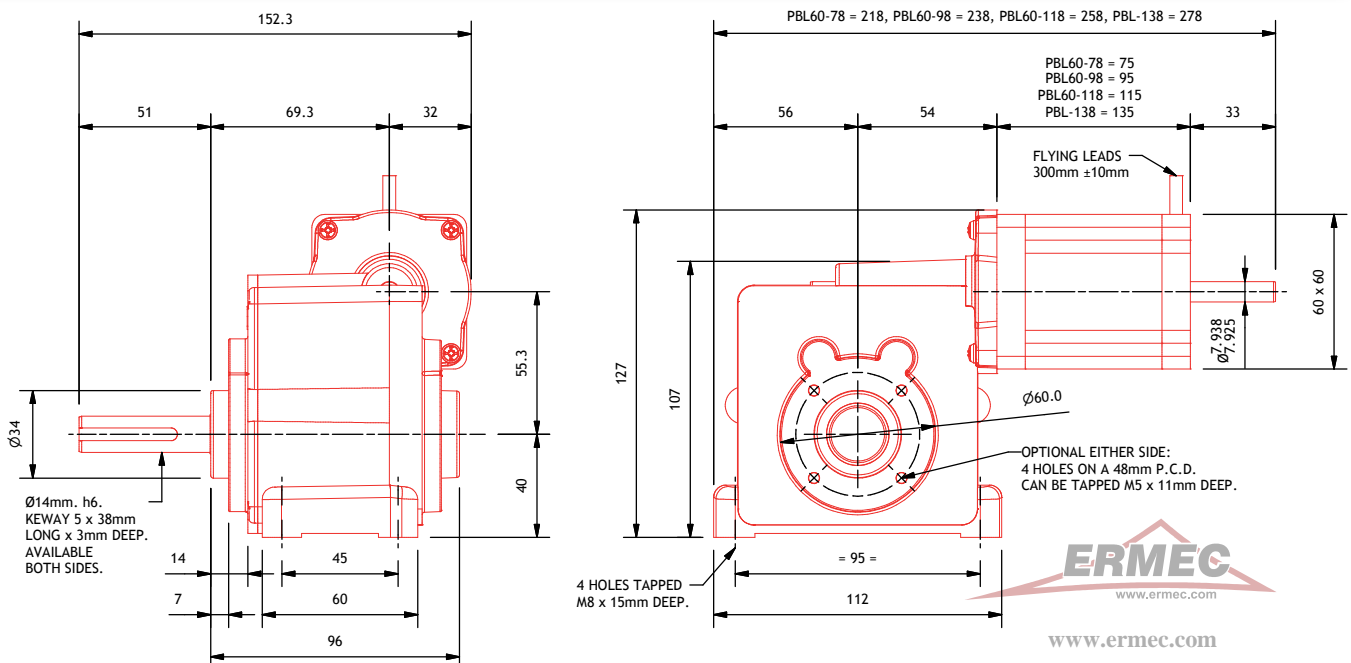

PBL60-118(IE)MWS

MOTOR	Brushless DC motor
PROTECTION	IP54 (IP50 at exposed rear motor shaft)
GEARBOX	Worm spur (MWS)
MOTOR POWER	50 - 134 Watts
SPEED*	1.1 - 98 rpm
VOLTAGE	24V DC
WEIGHT	4.1 kg
CONTROLLER	B (or integral with IE model)
SHAFT TYPE	Single ended or double ended shaft as standard
EXTRAS	See page 18



PBL60-118MWS pictured

See page 61 to specify shaft and gearbox position

*input speed variable up to 4000 rpm; other ratios available on request

Ratio		Final speed (rpm)				Rated torque Nm up to 4000 rpm	Peak torque Nm up to 2500 rpm	15 min rating Nm up to 3500 rpm
Worm	Spur	1500 rpm 50 W	2000 rpm 67 W	3000 rpm 101 W	4000 rpm 134 W			
40:1	35.39:1	1.1	1.4	2.1	2.8	45	45	45
27:1	35.39:1	1.6	2.1	3.1	4.2	45	45	45
18 1/2:1	35.39:1	2.3	3.1	4.6	6.1	45	45	45
12 1/2:1	35.39:1	3.4	4.5	6.8	9	45	45	45
9 1/3:1	35.39:1	4.5	6.1	9.1	12.1	45	45	45
7 1/4:1	35.39:1	5.8	7.8	11.7	15.6	45	45	45
8 1/3:1	15.1:1	11.9	15.9	24	32	22	22	22
7 1/4:1	15.1:1	13.7	18.3	27	37	22	22	22
6 1/4:1	15.1:1	15.9	21	32	42	22	22	22
8 1/3:1	6.5:1	28	37	55	74	9	9	9
7 1/4:1	6.5:1	32	42	64	85	9	9	9
6 1/4:1	6.5:1	37	49	74	98	9	9	9

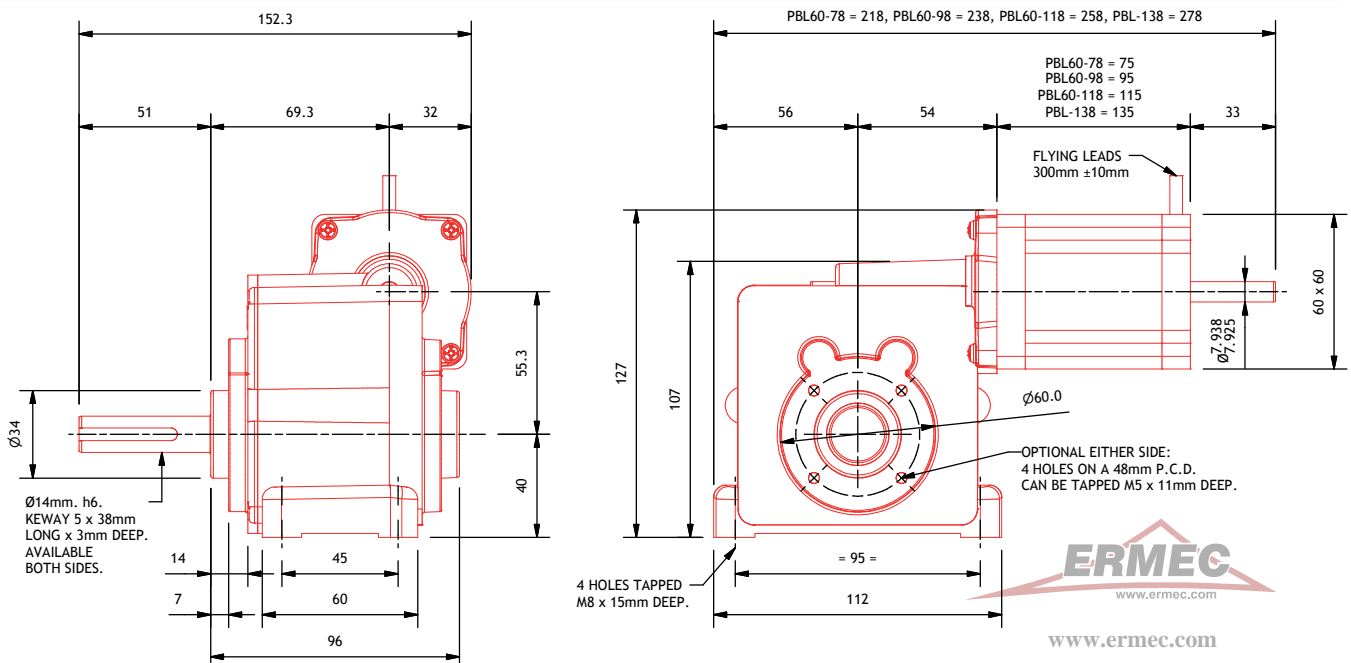

PBL60-78LWS

- MOTOR Brushless DC motor
- PROTECTION IP54 (IP50 at exposed rear motor shaft)
- GEARBOX Worm spur (LWS)
- MOTOR POWER 14 - 46 Watts
- SPEED* 0.8 - 80 rpm
- VOLTAGE 24V DC
- WEIGHT 4.6 kg
- CONTROLLER N
- SHAFT TYPE Single ended or double ended shaft as standard; 17mm diameter shaft available with ratios 115:1 and 56:1
- EXTRAS Gearbox available without feet; unit can be mounted on gearbox spigot; for further options see page 18



*input speed variable up to 4000 rpm; other ratios available on request

See page 61 to specify shaft and gearbox position

Ratio		Final speed (rpm)				Rated torque Nm up to 4000 rpm	Peak torque Nm up to 2500 rpm	15 min rating Nm up to 3500 rpm
Worm	Spur	1500 rpm 17 W	2000 rpm 23 W	3000 rpm 35 W	4000 rpm 46 W			
16 1/2:1	115:1	0.8	1.1	1.6	2.1	100	100	100
8 1/3:1	115:1	1.6	2.1	3.1	4.2	64	100	82
12 1/2:1	56:1	2.1	2.9	4.3	5.7	42	84	54
8 1/3:1	56:1	3.2	4.3	6.4	8.6	31	63	40
6 1/4:1	56:1	4.3	5.7	8.6	11.4	25	50	32
12 1/2:1	25:1	4.8	6.4	9.6	12.8	18.9	38	24
8 1/3:1	25:1	7.2	9.6	14.4	19.2	14	28	17.8
6 1/4:1	25:1	9.6	12.8	19.2	26	11.3	23	14.3
16 1/2:1	6:1	15.2	20	30	40	5.5	11	7
8 1/3:1	6:1	30	40	60	80	3.4	6.7	4.3

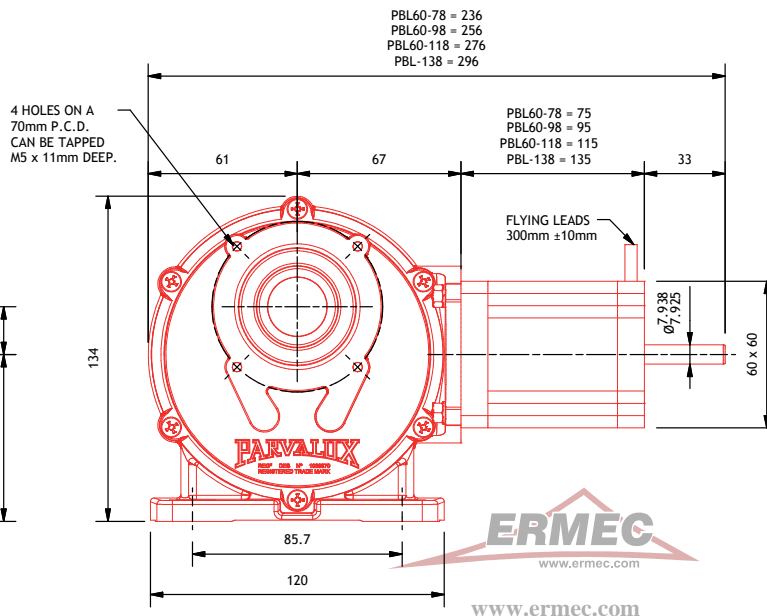
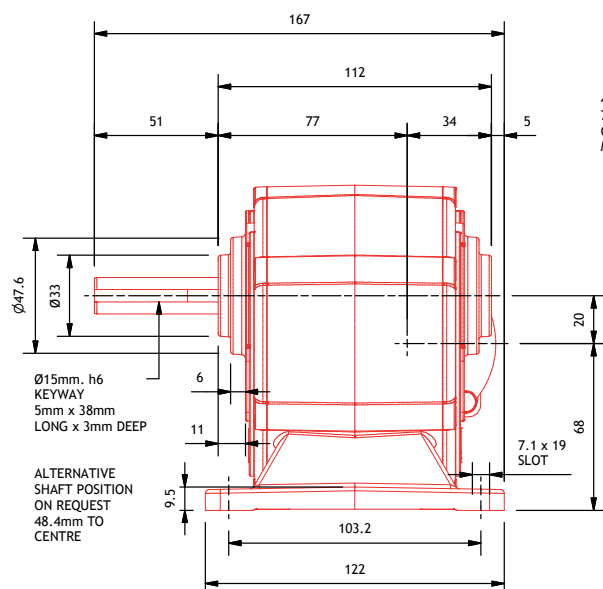

PBL60-98(IE)LWS

PARVALUX®

MOTOR	Brushless DC motor
PROTECTION	IP54 (IP50 at exposed rear motor shaft)
GEARBOX	Worm spur (LWS)
MOTOR POWER	35 - 92 Watts
SPEED*	0.8 - 80 rpm
VOLTAGE	24V DC
WEIGHT	4.9 kg
CONTROLLER	N (or integral with IE model)
SHAFT TYPE	Single ended or double ended shaft as standard; 17mm diameter shaft available with ratios 115:1 and 56:1
EXTRAS	Gearbox available without feet; unit can be mounted on gearbox spigot; for further options see page 18



PBL60-98LWS pictured

See page 61 to specify shaft and gearbox position

*input speed variable up to 4000 rpm; other ratios available on request

Ratio		Final speed (rpm)				Rated torque Nm up to 4000 rpm	Peak torque Nm up to 2500 rpm	15 min rating Nm up to 3500 rpm
Worm	Spur	1500 rpm 35 W	2000 rpm 46 W	3000 rpm 69 W	4000 rpm 92 W			
16 1/2:1	115:1	0.8	1.1	1.6	2.1	100	100	100
8 1/3:1	115:1	1.6	2.1	3.1	4.2	100	100	100
12 1/2:1	56:1	2.1	2.9	4.3	5.7	84	100	100
8 1/3:1	56:1	3.2	4.3	6.4	8.6	63	100	80
6 1/4:1	56:1	4.3	5.7	8.6	11.4	50	100	64
12 1/2:1	25:1	4.8	6.4	9.6	12.8	38	62	48
8 1/3:1	25:1	7.2	9.6	14.4	19.2	28	56	36
6 1/4:1	25:1	9.6	12.8	19.2	26	23	45	29
16 1/2:1	6:1	15.2	20	30	40	11	22	14
8 1/3:1	6:1	30	40	60	80	6.7	13.4	8.5

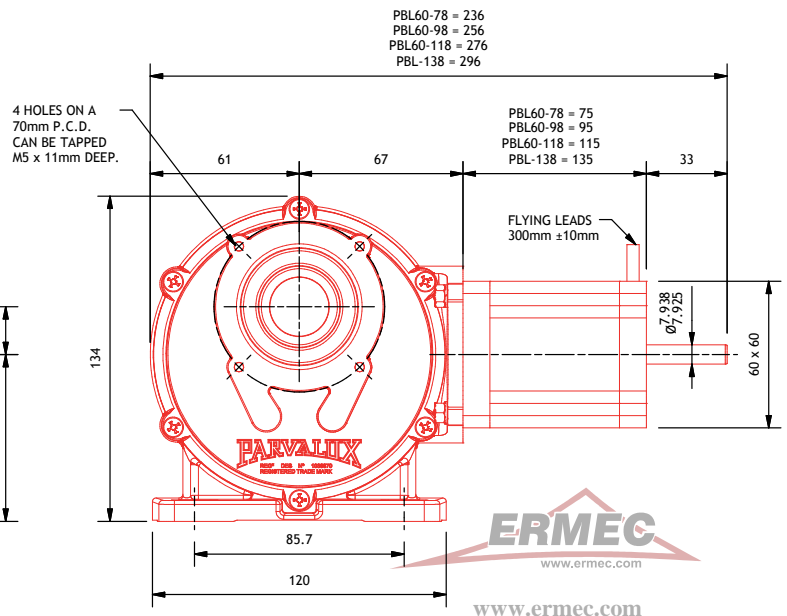
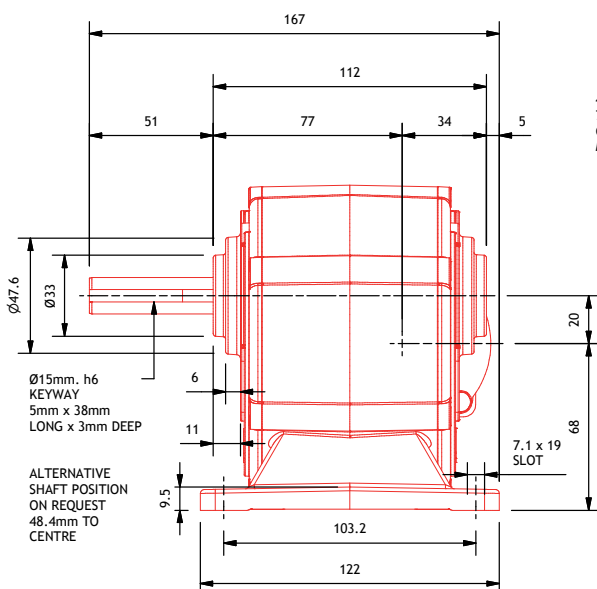

PBL60-118(IE)LWS



- MOTOR Brushless DC motor
- PROTECTION IP54 (IP50 at exposed rear motor shaft)
- GEARBOX Worm spur (LWS)
- MOTOR POWER 50 - 134 Watts
- SPEED* 0.8 - 80 rpm
- VOLTAGE 24V DC
- WEIGHT 5.2 kg
- CONTROLLER B (or integral with IE model)
- SHAFT TYPE Single ended or double ended shaft as standard; 17mm diameter shaft available with ratios 115:1 and 56:1
- EXTRAS Gearbox available without feet; unit can be mounted on gearbox spigot; for further options see page 18

PBL60-118LWS pictured

See page 61 to specify shaft and gearbox position

*input speed variable up to 4000 rpm; other ratios available on request

Ratio		Final speed (rpm)				Rated torque Nm up to 4000 rpm	Peak torque Nm up to 2500 rpm	15 min rating Nm up to 3500 rpm
Worm	Spur	1500 rpm 50 W	2000 rpm 67 W	3000 rpm 101 W	4000 rpm 134 W			
16 1/2:1	115:1	0.8	1.1	1.6	2.1	100	100	100
8 1/3:1	115:1	1.6	2.1	3.1	4.2	100	100	100
12 1/2:1	56:1	2.1	2.9	4.3	5.7	100	100	100
8 1/3:1	56:1	3.2	4.3	6.4	8.6	91	100	100
6 1/4:1	56:1	4.3	5.7	8.6	11.4	73	100	92
12 1/2:1	25:1	4.8	6.4	9.6	12.8	55	62	62
8 1/3:1	25:1	7.2	9.6	14.4	19.2	41	62	51
6 1/4:1	25:1	9.6	12.8	19.2	26	33	62	41
16 1/2:1	6:1	15.2	20	30	40	16	32	20
8 1/3:1	6:1	30	40	60	80	9.8	19.5	12.2

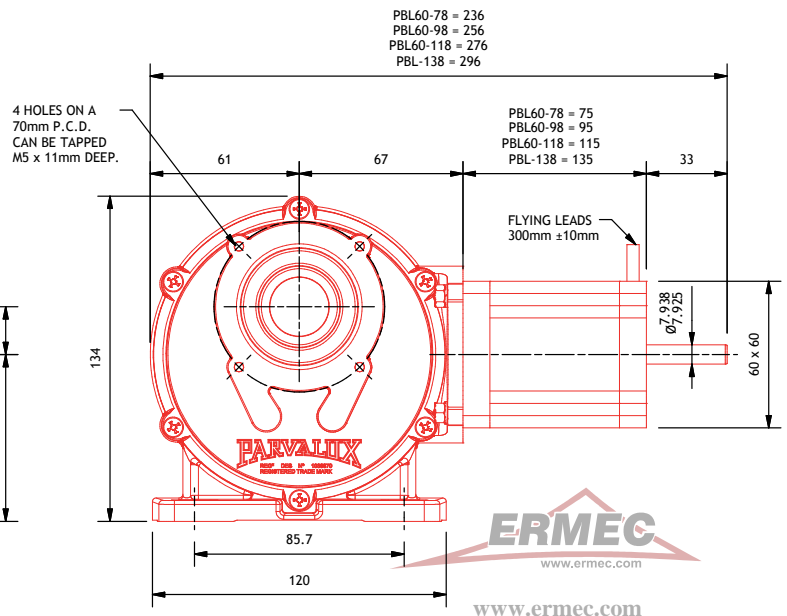
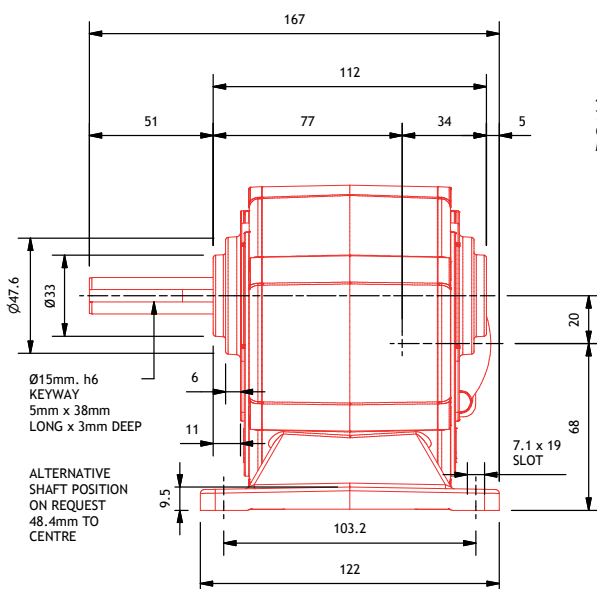

PBL60-138(IE)LWS

PARVALUX®

- MOTOR Brushless DC motor
- PROTECTION IP54 (IP50 at exposed rear motor shaft)
- GEARBOX Worm spur (LWS)
- MOTOR POWER 69 - 184 Watts
- SPEED* 0.8 - 80 rpm
- VOLTAGE 24V DC (or 48V DC with IE model)
- WEIGHT 5.5 kg
- CONTROLLER B (or integral with IE model)
- SHAFT TYPE Single ended or double ended shaft as standard; 17mm diameter shaft available with ratios 115:1 and 56:1
- EXTRAS Gearbox available without feet; unit can be mounted on gearbox spigot; for further options see page 18



*input speed variable up to 4000 rpm; other ratios available on request

See page 61 to specify shaft and gearbox position

Ratio		Final speed (rpm)				Rated torque Nm up to 4000 rpm	Peak torque Nm up to 2500 rpm	15 min rating Nm up to 3500 rpm
Worm	Spur	1500 rpm 69 W	2000 rpm 92 W	3000 rpm 138 W	4000 rpm 184 W			
16 1/2:1	115:1	0.8	1.1	1.6	2.1	100	100	100
8 1/3:1	115:1	1.6	2.1	3.1	4.2	100	100	100
12 1/2:1	56:1	2.1	2.9	4.3	5.7	100	100	100
8 1/3:1	56:1	3.2	4.3	6.4	8.6	100	100	100
6 1/4:1	56:1	4.3	5.7	8.6	11.4	100	100	100
12 1/2:1	25:1	4.8	6.4	9.6	12.8	62	62	62
8 1/3:1	25:1	7.2	9.6	14.4	19.2	56	62	62
6 1/4:1	25:1	9.6	12.8	19.2	26	45	62	56
16 1/2:1	6:1	15.2	20	30	40	22	44	28
8 1/3:1	6:1	30	40	60	80	13.4	27	16.8

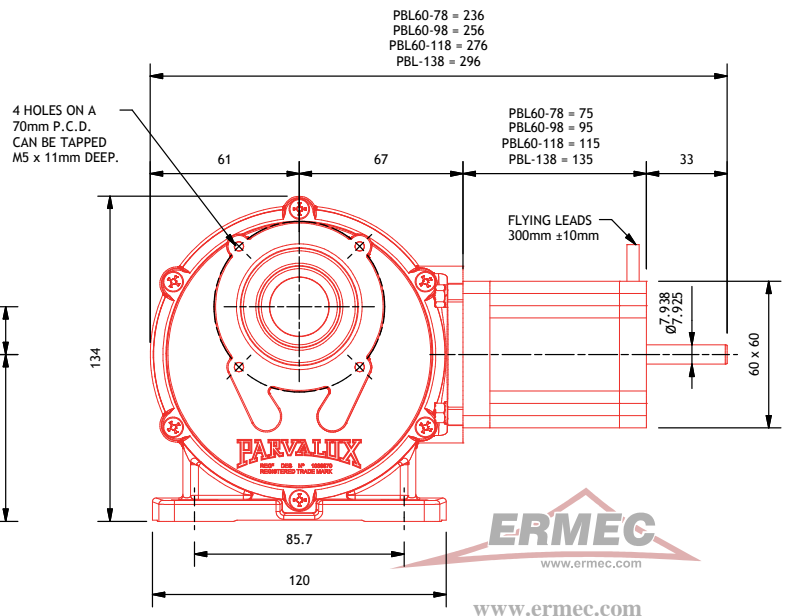
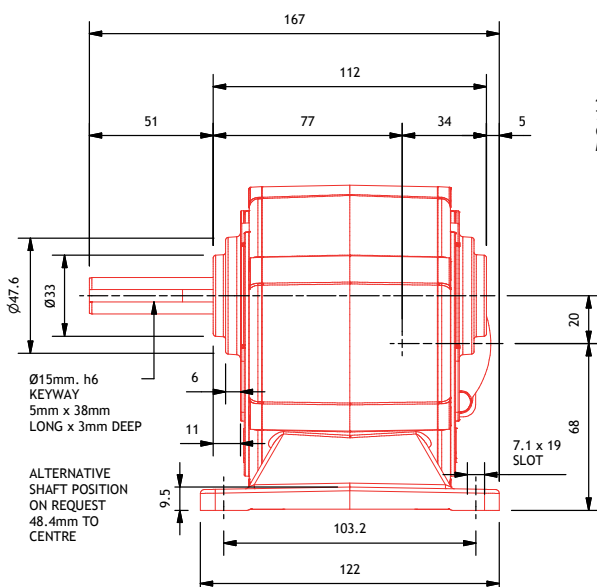

PBL60-118(IE)GWS

PARVALUX®

MOTOR	Brushless DC motor
PROTECTION	IP54 (IP50 at exposed rear motor shaft)
GEARBOX	Worm spur (GWS)
MOTOR POWER	50 - 134 Watts
SPEED*	0.5 - 44 rpm
VOLTAGE	24V DC
WEIGHT	8.3 kg
CONTROLLER	B (or integral with IE model)
SHAFT TYPE	Single ended or double ended shaft as standard
EXTRAS	See page 18



PBL60-118GWS pictured

See page 61 to specify shaft and gearbox position

*input speed variable up to 4000 rpm; other ratios available on request

Ratio		Final speed (rpm)				Rated torque Nm up to 4000 rpm	Peak torque Nm up to 2500 rpm	15 min rating Nm up to 3500 rpm
Worm	Spur	1500 rpm 50 W	2000 rpm 67 W	3000 rpm 101 W	4000 rpm 134 W			
30:1	110:1	0.5	0.6	0.9	1.2	250	250	250
16 1/2:1	110:1	0.8	1.1	1.7	2.2	250	250	250
9 1/3:1	110:1	1.5	1.9	2.9	3.9	195	250	244
7 1/4:1	110:1	1.9	2.5	3.8	5	161	250	202
7 1/4:1	57:1	3.6	4.8	7.3	9.7	84	167	104
10 1/3:1	25:1	5.8	7.7	11.6	15.5	49	99	62
8 1/3:1	25:1	7.2	9.6	14.4	19.2	42	84	53
12 1/3:1	11:1	11.1	14.7	22	29	26	52	32
8 1/3:1	11:1	16.4	22	33	44	19.4	39	24

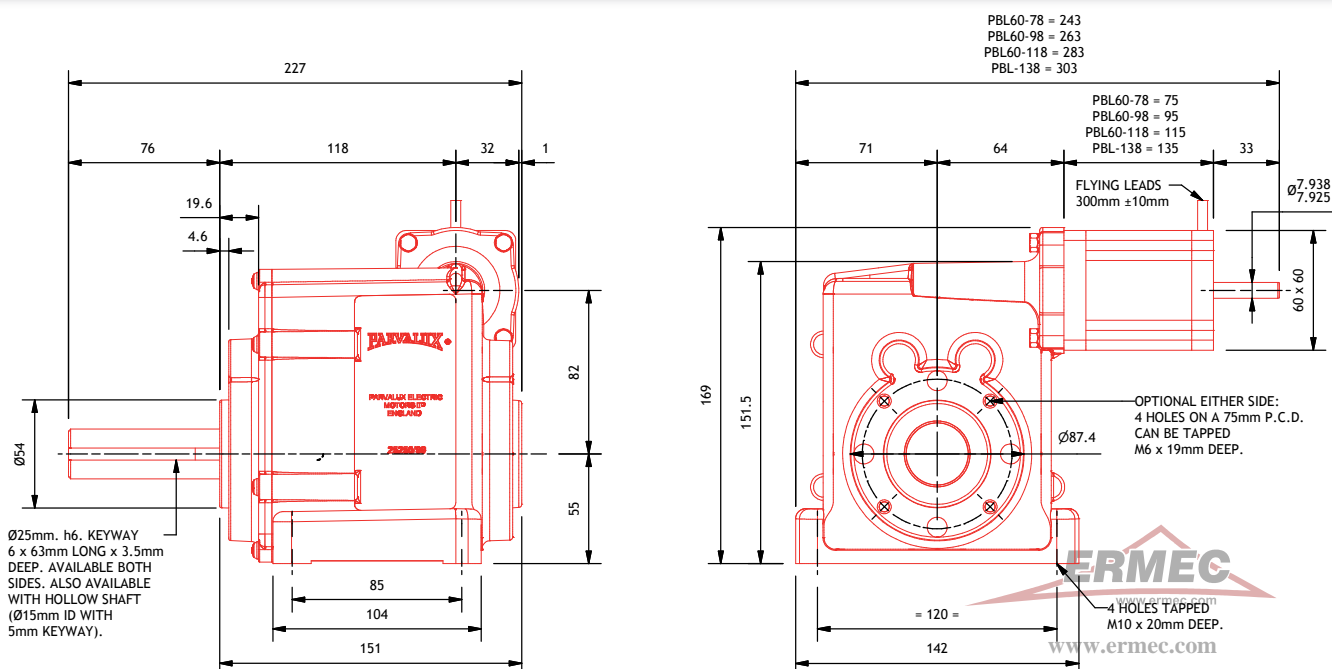

PBL60-138(IE)GWS

PARVALUX®

MOTOR	Brushless DC motor
PROTECTION	IP54 (IP50 at exposed rear motor shaft)
GEARBOX	Worm spur (GWS)
MOTOR POWER	69 - 184 Watts
SPEED*	0.5 - 44 rpm
VOLTAGE	24V DC
WEIGHT	8.6 kg
CONTROLLER	B (or integral with IE model)
SHAFT TYPE	Single ended or double ended shaft as standard
EXTRAS	See page 18



PBL60-138GWS pictured

See page 61 to specify shaft and gearbox position

*input speed variable up to 4000 rpm; other ratios available on request

Ratio		Final speed (rpm)				Rated torque Nm up to 4000 rpm	Peak torque Nm up to 2500 rpm	15 min rating Nm up to 3500 rpm
Worm	Spur	1500 rpm 69 W	2000 rpm 92 W	3000 rpm 138 W	4000 rpm 184 W			
30:1	110:1	0.5	0.6	0.9	1.2	250	250	250
16 1/2:1	110:1	0.8	1.1	1.7	2.2	250	250	250
9 1/3:1	110:1	1.5	1.9	2.9	3.9	250	250	250
7 1/4:1	110:1	1.9	2.5	3.8	5	222	250	250
7 1/4:1	57:1	3.6	4.8	7.3	9.7	115	230	144
10 1/3:1	25:1	5.8	7.7	11.6	15.5	68	136	85
8 1/3:1	25:1	7.2	9.6	14.4	19.2	58	116	72
12 1/3:1	11:1	11.1	14.7	22	29	36	71	44
8 1/3:1	11:1	16.4	22	33	44	27	53	33

PBL60-78 = 243
PBL60-98 = 263
PBL60-118 = 283
PBL-138 = 303

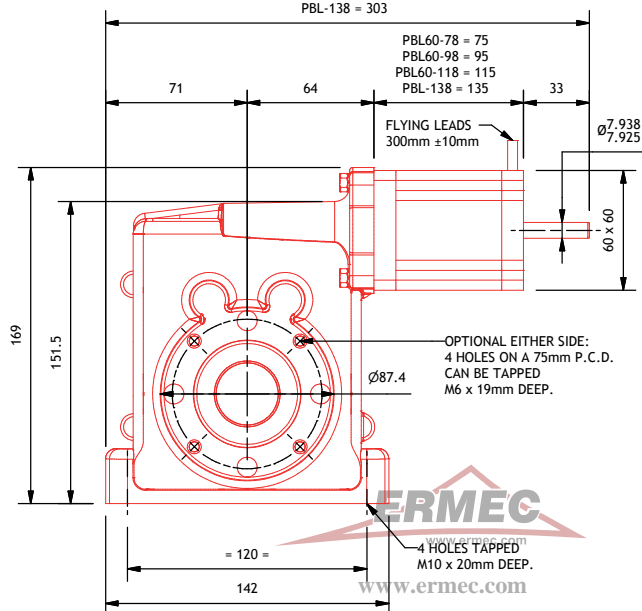
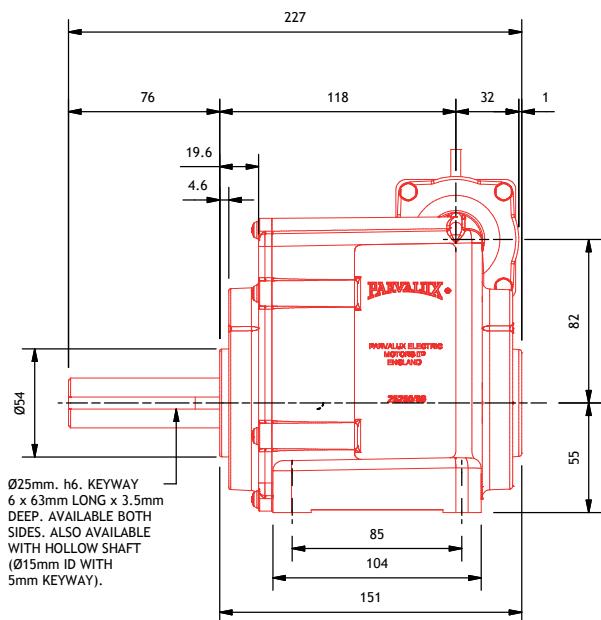

flange options 1

Alternative gearbox fixing lid with 3 tapped holes
Available for S, M & L worm-wheel gearboxes

	S3P	M3P	L3P
Fixing holes	3 x M6	3 x M6	3 x M8
PCD	42mm	50.8mm	72mm



L3P pictured

Parvalux S3P fixing option

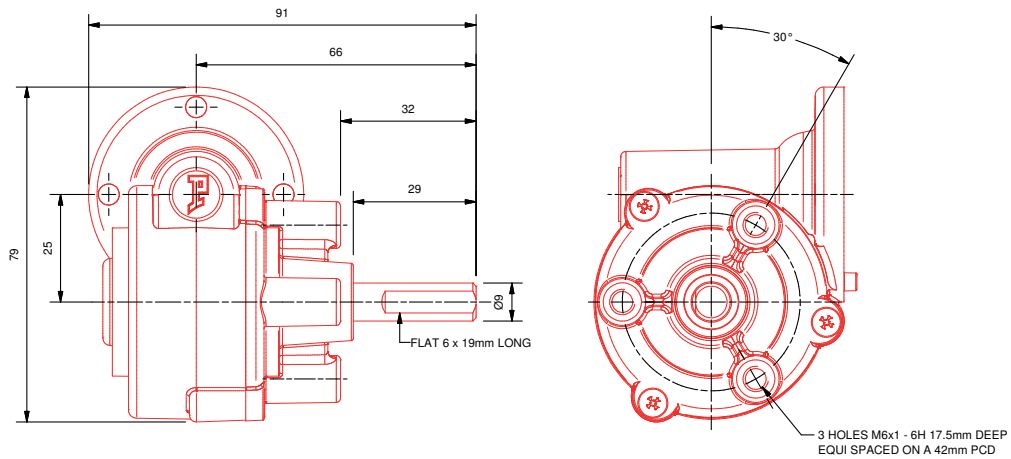

Parvalux M3P fixing option

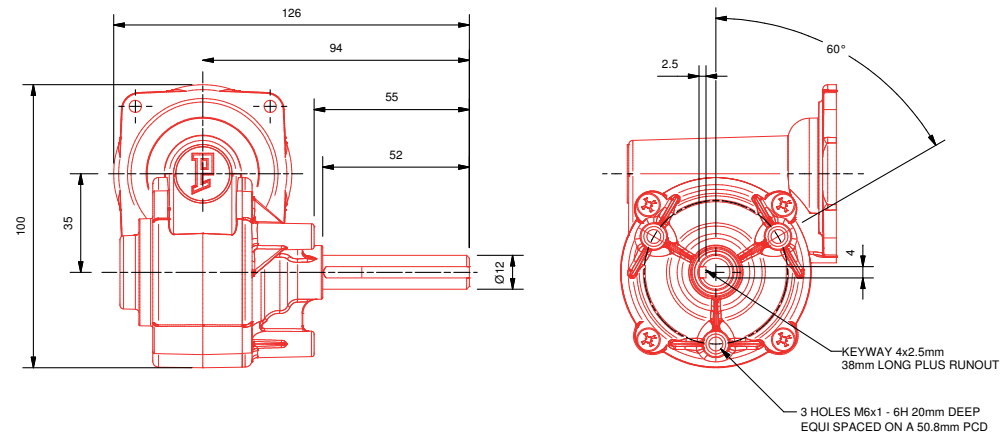

Parvalux L3P fixing option

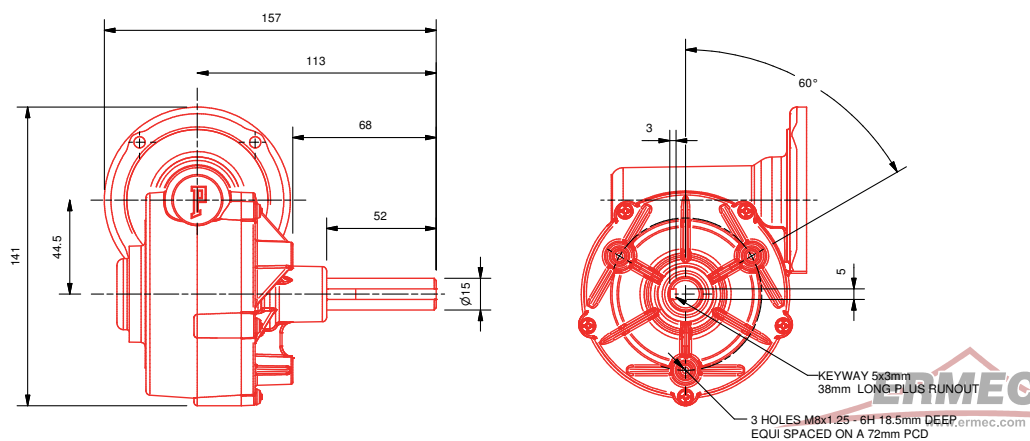

flange options 2

Alternative gearbox flange with 4 tapped holes
Available for M & L worm-wheel gearboxes



LF pictured

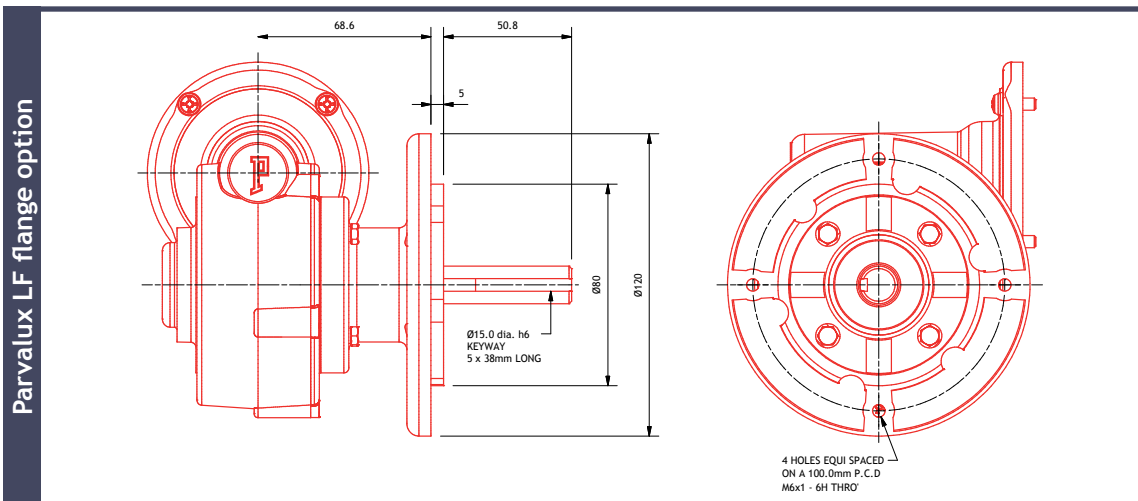
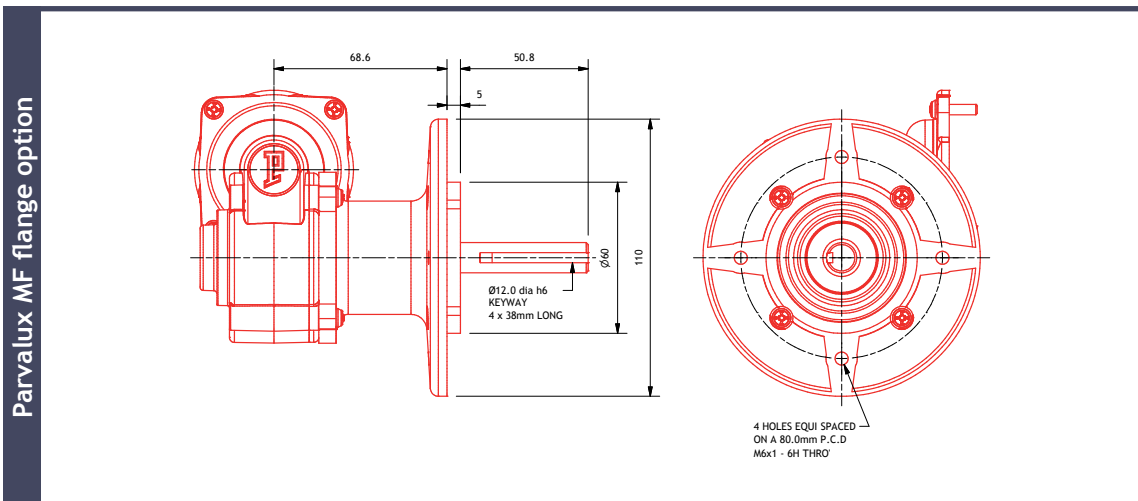

spring applied brakes

Fail safe, spring applied, electromagnetic release brakes
 Holding and stopping applications
 Mounted to rear of motor
 Environmental protection up to IP55
 Other brakes available on request



PBL86-91 with holding/dynamic brake pictured

Type	Holding/dynamic brake	Holding/dynamic brake
Torque	0.4 Nm	1.0 Nm
Motor range	PBL60	PBL86
Additional length	38 mm	30 mm
Supply voltage	24 V DC	24 V DC
Coil power	14 W	14 W
Max. stopping power	50 kJ/h	50 kJ/h
Connections	300 mm flying leads	300 mm flying leads
Protection	IP55	IP55

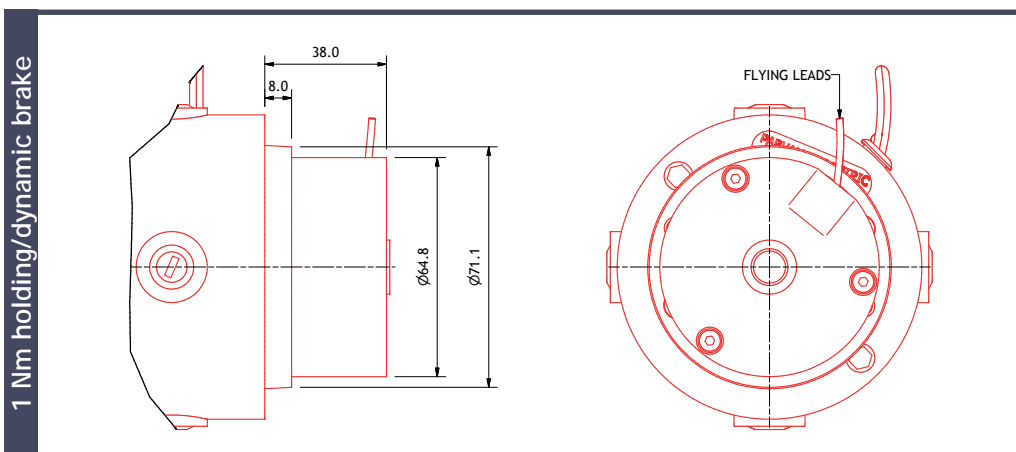

1 Nm holding/dynamic brake

incremental encoder

HEDS compatible 2 channel encoder with index pulse
Standard line count 500 CPR (up to 1250 CPR available)
Supply voltage 5 V
Output voltage TTL compatible
Mounted to rear of motor



PBL60-78 with encoder pictured

Motor ranges	PBL42; PBL60; PBL86
Additional length	21 mm
Current consumption	typ. 60 mA with no load
Connections	5-way socket for latching connector 300 mm flying leads available
Protection	IP30

encoder output signals

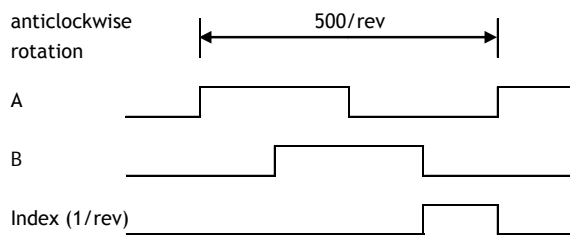

A leads B for anticlockwise motor rotation
(positive connected to red lead on PM motors)
Index pulse is gated with A and B both low

encoder connector

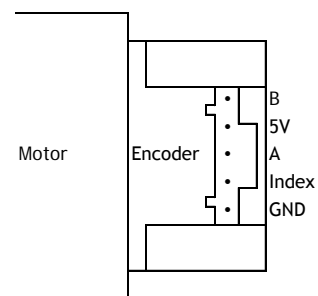

Standard incremental encoder

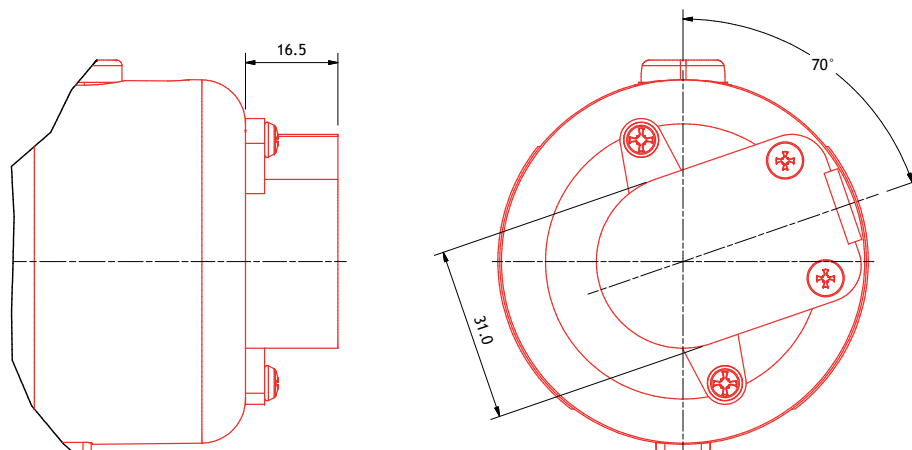

shaft and worm gearbox positions

Single shaft Y standard – Z shaft optional on request
Double shaft extensions Y and Z available at extra cost

Single reduction

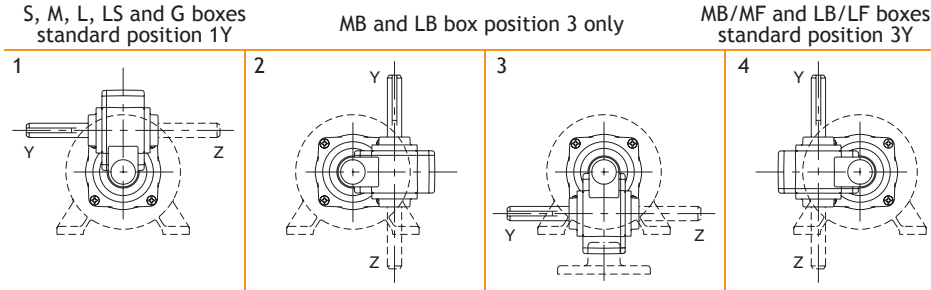

Double reduction

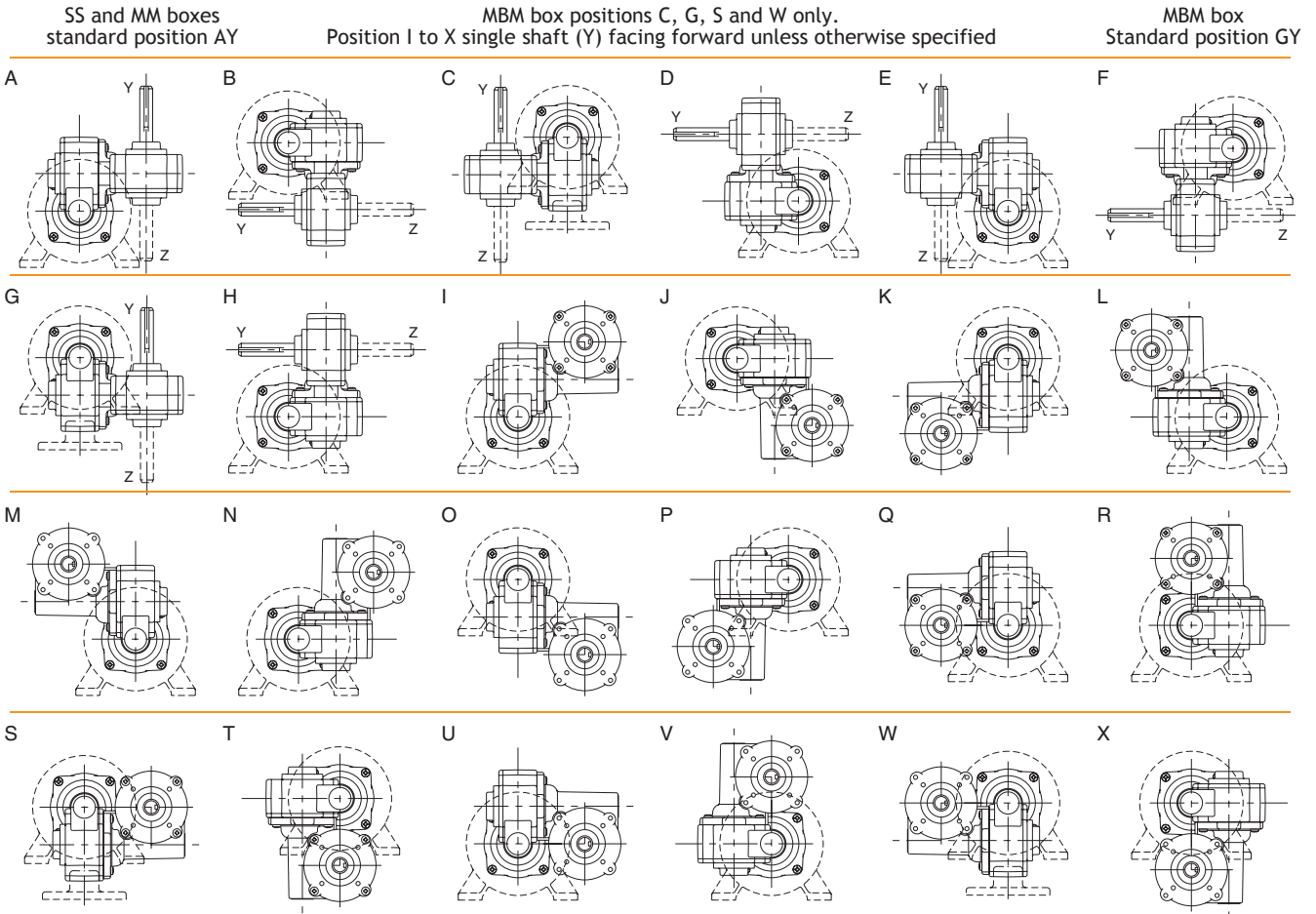

All the above positions correspond to the end elevation drawing of the appropriate unit with feet at the base of drawing.

Shaft positions worm and multi spur gearbox

Single shaft Y standard – Z shaft optional on request. Double shaft extensions Y and Z available at extra cost

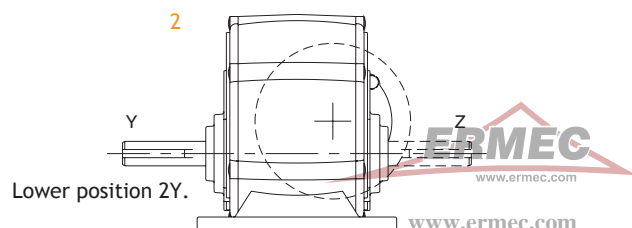
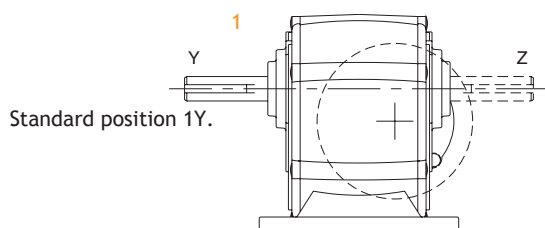

Torque Ratings

All gearbox torque figures have been reproduced to represent an accurate output figure. These figures may be affected by tolerances created during production techniques as well as application circumstances once the units have been installed. A margin of + or - 10% should be taken into consideration on these figures during your selection of an appropriate unit.

Gear units

- Worm gear units: The output shaft is pressed into gear wheels of composite or bronze, with hardened and polished steel worms.
- Worm/spur gear units: The drive pinion comprises either a composite or bronze worm gear with a pressed steel helical pinion insert driving a spur steel gear train rotating on intershafts. The final gear is pressed and keyed onto the final shaft.
- Spur units: The steel pinion drives helical/spur cut steel gears rotating on intershafts. The final gear is pressed and keyed onto the final shaft.
- Planetary units: The composite drive pinion drives a series of steel secondary gears.

Gearbox and quality ball bearings are packed with an appropriate grade of NLGI 1/2 grease as standard. All units are sealed for life utilising 'O' rings on all key mating surfaces and are suitable for running in any mounting position.

Gearbox positions

Alternative positions for the gearboxes can be arranged to suit customer requirements but unless specified, will be supplied in standard position as shown on the individual drawings. This also applies to the gearbox shaft extensions.

Lubricants

Parvalux gearboxes are charged as standard with NLGI 1/2 rated grease and are sealed and lubricated for life. In certain conditions, Parvalux gearboxes may be filled with multi-grade (20/50) oil or semi-fluid grease and sealed for life. Working temperatures of lubricants: -

- Grease: - 15°C to +120°C
- Oil: - 15°C to +150°C

For

Single and double worm reduction gearboxes

Whilst worm gearing has lower efficiency than spur gearing it is true to say that generally the noise level of worm gear reduction is much lower and therefore, where noise is an important factor, this type of gearing should be considered. To prevent premature gear failure or excessive gear wear, the maximum gear loading and thermal rating of the particular gearbox must be taken into consideration; otherwise there is a danger of stripping the gear wheel teeth or failure of the lubrication due to excessive gearbox temperature. If further information is required on this point please consult our sales engineers.

Testing

To B.S. Specification 5000 Part II. All our units are CE marked and comply with current regulations/directives at time of printing.

mechanical data

GEARBOX TYPE	GEAR	RATIO / STAGE	MECHANICAL RATING (Nm)		THERMAL RATING (Watts)		*RADIAL LOADING (N)	AXIAL LOADING (N)
			Composite	Bronze	Composite	Bronze		
S	Worm	4 1/8:1 to 40:1	2.9	4.5	20	25	69	35
		44:1 to 60:1	2.3	4				
		66:1 to 70:1	1.5	2.5				
M	Worm	4 1/8:1 to 40:1	7.9	11.8	38	45	132	88
		44:1 to 60:1	5.9	7.9				
		66:1 to 72:1	5.1	7.3				
MB or MF	Worm	4 1/8:1 to 40:1	7.9	11.8	40	48	226	108
		44:1 to 60:1	5.9	7.9				
		66:1 to 72:1	5.1	7.3				
L or LH	Worm	5:1 to 40:1	14.6	22	60	72	177	132
		50:1 to 60:1	11.3	17				
LS or LSH	Worm	5:1 to 40:1	14.6	22	60	72	314	196
		50:1 to 60:1	11.3	17				
LB or LF or LHB	Worm	5:1 to 40:1	14.6	-	60	72	314	157
		50:1 to 60:1	11.3	17				
G or GH	Worm	12 1/2:1 to 75:1	50	-	100	-	491	294
SS	Double worm	47:1 to 2880:1	4	5.9	25	30	54	35
		3000:1 to 4300:1	2.7	4				
		4320:1 to 4900:1	1.5	2.5				
MM	Double worm	47:1 to 2880:1	9	11.8	45	54	88	88
		3000:1 to 4300:1	5.9	7.9				
		4320:1 to 5184:1	5.1	7.3				
MBM	Double worm	47:1 to 2880:1	9	11.8	47	58	177	108
		3000:1 to 4300:1	5.9	7.9				
		4320:1 to 5184:1	5.1	7.3				
SIW	In-line worm	ALL RATIOS	7	11.3	28	38	78	49
MIW	In-line worm	ALL RATIOS	17	28	50	65	265	132
LIW	In-line worm	ALL RATIOS	28	45	-	-	353	196
SIS	In-line spur	22:1 to 33:1	5.7		-	-	88	44
		53:1 to 347:1	7.9					
MIS	In-line spur	5.73:1 SPUR	12		-	-	216	137
		13.45:1 SPUR	28					
		31.3:1 SPUR	45					
LIS	In-line spur	6:1 SPUR	23		-	-	265	177
		25:1 SPUR	51					
		56:1/115:1 SPUR	74					
SWS	Worm/spur	ALL RATIOS	11		-	-	177	112
MWS	Worm/spur	6.5:1 SPUR	9		-	-	353	177
		15.1:1 SPUR	22					
		35.39:1 SPUR	45					
LWS	Worm/spur	6:1 SPUR	45		-	-	446	226
		25:1 SPUR	62					
		56:1/115:1 SPUR	100					
GWS	Worm/spur	11:1 SPUR	90		-	-	667	353
		25:1 SPUR	200					
		57:1/110:1 SPUR	250					

* Based on midway point of standard shaft extension

gearbox thermal rating limits

PRODUCTS Parvalux worm gearboxes S, M, MB, MF, L, LH, LB, LF, LHB, LS, LSH, G, GH, SS, MM, MBM, SIW, MIW

ENCLOSED Table 1 (thermal rating), table 2 (worm efficiency)

NOTE For the above range of gearboxes, the maximum continuous output power (S1 duty cycle) is limited by the maximum thermal rating of the gearbox. The following datasheet describes the required calculation.

TABLE 1: Maximum thermal rating (Watts)

Gearbox Type	Thermal Rating (Watts)	
	Composite	Bronze
S	20	25
M	38	45
MB, MF	40	48
L, LH, LB, LF, LHB, LS, LSH	60	72
G, GH	100	-
SS	25	30
MM	45	54
MBM	47	58
SIW	28	38
MIW	50	65

EXAMPLE 1

Using the gearbox efficiency figures attached (table 2), an example calculation is as follows: PM7S, 4000 rpm input speed, 70:1 ratio (delrin), 57 rpm output speed, 1.2Nm required.

$$\therefore \text{Approx. thermal rating (W)} = \frac{57 \times 1.2}{9.55} \times \left(\frac{1}{0.330} - 1 \right) = 7.16 \times 2.03 = 14.5 \text{ W}$$

The thermal rating of the S gearbox is 20W (from table 1) and therefore the maximum continuous output torque of 1.2Nm is acceptable.

EXAMPLE 2

PM7S, 4000 rpm input speed, 44:1 ratio (delrin), 91 rpm output speed, 2.3Nm required continuously run.

$$\therefore \text{Approx. thermal rating (W)} = \frac{91 \times 2.3}{9.55} \times \left(\frac{1}{0.419} - 1 \right) = 21.92 \times 1.39 = 30.4 \text{ W}$$

The thermal rating of the S gearbox is 20W (from table 1) and therefore the 30.4W exceeds the maximum rating by over 50%. This will damage the gearbox; therefore the S gearbox is insufficient for this application.

EXAMPLE 3

PM7S, 4000 rpm input speed, 44:1 ratio (delrin), 91 rpm output speed, 2.3Nm required with a duty cycle of 20%.

$$\text{Approx. thermal rating (W)} = \frac{91 \times 2.3}{9.55} \times \left(\frac{1}{0.419} - 1 \right) = 21.92 \times 1.39 = 30.4 \text{ W}$$

$$x = \sqrt{\left(\frac{100}{20} \right)} = 2.24$$

$$\therefore \text{Approx. intermittent thermal rating (W)} = 20 \times 2.24 = 44.8 \text{ W}$$

The thermal rating of the S gearbox is 20W (from table 1), but due to the low duty cycle of the application the thermal rating of the gearbox of 30.4W is within the maximum intermittent rating of 44.8W.

CONTINUOUS DUTY CYCLE (S1)

The thermal rating of the gearbox can be calculated using the following formula: -

$$\text{Approx. thermal rating (W)} = \frac{\text{Final RPM} \times \text{Torque (Nm)}}{9.55} \times \left(\frac{1}{\eta} - 1 \right)$$

η = efficiency of the gearbox (see below)

INTERMITTENT DUTY CYCLE

For intermittent duty the thermal rating for the gearbox (table 1) is increased by multiplying the appropriate gearbox thermal rating by the factor x:

$$x = \sqrt{\left(\frac{100\%}{\text{Duty cycle \%}} \right)}$$

TABLE 2: Gearbox efficiency

Single worm efficiency (except G box)			
Ratio	Effcy	Ratio	Effcy
4 1/8	0.845	22 1/2	0.540
5 1/6	0.804	24 1/2	0.524
6 1/4	0.770	25	0.521
7 1/4	0.743	27	0.507
8 1/3	0.718	30	0.488
9 1/3	0.698	33	0.471
10 1/3	0.680	36	0.455
11 1/3	0.663	40	0.436
12 1/3	0.645	44	0.419
13 1/2	0.632	48	0.403
14 1/2	0.619	54	0.382
15 1/2	0.607	60	0.363
16 1/2	0.595	66	0.346
18 1/2	0.575	72	0.330
20 1/2	0.556		

Single worm efficiency (G box)	
Ratio	Effcy
12 1/2	0.75
25	0.69
30	0.66
50	0.61
60	0.58
75	0.56



EMC directive compliance

PRODUCT	PBL42, PBL60, PBL86 motor and controller packages
DIRECTIVE	2004/108/EC
STANDARDS	EN61000-6-1 Class B Immunity EN61000-6-2 Class A Immunity EN61000-6-3 Class B Emissions EN61000-6-4 Class A Emissions

In order to meet the above EMC standards, an EMC filter is required in the power supply line to the motor controller. PBL42 and PBL60 motors require a 10A filter; PBL86 motors require a 25A filter. The PBL86 additionally requires a ferrite sleeve fitted over the Hall sensor leads close to the controller, only if meeting EN61000-6-2 is a requirement.

ACCESSORY	10A FILTER	25A FILTER	FERRITE SLEEVE
			
Parvalux part no.	50296	50297	50298
Dimensions (mm)	40 dia x 75 long	46 dia x 98 long	11.5 dia x 25 long

EMC INSTALLATION REQUIREMENTS

1. The motor and controller cases should be earthed.
2. The connection between power supply and controller must be less than 3m in length.
3. The motor should be connected to the controller using the leads supplied.
4. If the motor leads need to be modified, the replacement cable must meet these conditions: -
 - a. Screened cable should be used over the whole length from controller to motor.
 - b. The 3 motor phase leads and 5 Hall sensor leads must be 2 separate screened cables.
 - c. The cable screens must be connected to earth at both ends.
 - d. The cables should be less than 3m in length.
5. The equipment is installed such that during operation, there is no risk of electrostatic discharge reaching the exposed screw heads on the connectors to the controller.

ERMEC, S.L. BARCELONA
C/ Francesc Teixidó, 22
E-08918 Badalona
(Spain)

Tel.: (+34) 902 450 160
Fax: (+34) 902 433 088
info@ermec.com
www.ermec.com

ERMEC, S.L. MADRID
C/ Sagasta, 8, 1ª planta
E-28004 Madrid
(Spain)

PORTUGAL
portugal@ermec.com
BILBAO
bilbao@ermec.com

CE Marking

With the declaration of conformity and the CE mark on the product the manufacturer certifies that the product complies with the requirements of all relevant EC New Approach Directives. For each of the relevant New Approach Directives the manufacturer is to adopt an appropriate Harmonised Standard.

Machinery Directive 98/37/EC

The Machinery Directive describes a machine as “an assembly of linked parts or components, at least one of which moves, with the appropriate actuators, control and power circuits, etc., joined together for a specific application...” Parvalux products as supplied do not have a specific application as they do not perform a complete mechanical function and must be installed by a competent person. As a result, compliance with the Machinery Directive is not required provided that a safety standard relevant to the type of equipment is adopted, for example the generic electrical safety standard EN60204-1.

Electromagnetic Compatibility Directive 89/336/EEC - 2004/108/EC

The Electromagnetic Compatibility (EMC) Directive exists to govern the radio frequency electromagnetic emissions from equipment such that in its intended use it does not disturb other equipment. The Directive also governs the immunity of electrical equipment containing electronic components to electromagnetic interference that may be produced by other electrical equipment. Parvalux products comply with the EMC Directive when installed in accordance with the manufacturer's instructions.

Low Voltage Directive 73/23/EEC - 2006/95/EC

The Low Voltage Directive exists to ensure that electrical equipment is safe in respect of all risks, electrical and otherwise. Parvalux chooses to adopt EN60204-1 for motors within the scope of the Low Voltage Directive, and also to comply with the safety aspects of this standard for motors with operating voltages below the scope of the LVD. Equipment with voltage ratings in the range 50-1000Vac and 75-1500Vdc is covered.

CE Marking and the responsibilities of the customer

It is the responsibility of the customer or machine manufacturer who places an assembly or finished product using a Parvalux product on the market within the EC, to comply with the New Approach Directives relevant to that assembly or finished product.

Standards for safe operation

EN60034-1:2004	Rotating electrical machines. Rating and performance.
EN60034-5:2001	Rotating electrical machines. Degrees of protection provided by the integral design of rotating electrical machines (IP code).
EN60034-6:1991	Rotating electrical machines. Methods of cooling (IC code).
EN60034-8:2002	Rotating electrical machines. Terminal markings and direction of rotation.
EN60034-9:2005	Rotating electrical machines. Noise limits.
EN60034-11:2004	Rotating electrical machines. Thermal protection.
EN60034-12:2002	Rotating electrical machines. Starting performance of single-speed three-phase cage induction motors.
EN60034-18-1:1994	Rotating electrical machines. Functional evaluation of insulation systems. General guidelines.
EN60204-1:2006	Electrical equipment of machines. General requirements.

Standards for compliance with EMC limit values

EN55014-1:2006	Electromagnetic compatibility. Requirements for household appliances, electric tools and similar apparatus. Emission.
EN61000-6-1:2007	Electromagnetic compatibility (EMC). Generic standards. Immunity for residential, commercial and light-industrial environments.
EN61000-6-2:2006	Electromagnetic compatibility (EMC). Generic standards. Immunity for industrial environments.
EN61000-6-3:2007	Electromagnetic compatibility (EMC). Generic standards. Emission standard. For residential, commercial and light-industrial environments.
EN61000-6-4:2007	Electromagnetic compatibility (EMC). Generic standards. Emission standard. For industrial environments.

IP protection

The degree of protection from ingress of foreign bodies and liquids, and the prevention of a person from touching live or moving parts, are indicated by the two digits in the IP code detailed below. For rotating electrical machines the classification is recognised internationally and is described in detail in EN 60034-5:2001.

First (IP) Number

Protection against solid foreign objects

IP	Protection of the machine from harmful ingress of solid foreign objects	Prevention of a person from touching live or moving parts:
0	No protection	No prevention
1	Protected from solid objects greater than 50 mm diameter	No access for a part of the human body such as a hand
2	Protected from solid objects greater than 12 mm diameter	No access for a part of the human body such as a finger
3	Protected from solid objects greater than 2.5 mm diameter	No access for a hand-held object such as a small tool 2.5 mm diameter
4	Protected from solid objects greater than 1 mm diameter	No access for a hand-held object such as a wire 1 mm diameter
5	Protection from dust (limited ingress with no harmful effects is permitted)	No access to live or moving parts
6	Totally protected from ingress of dust	No access to live or moving parts

If an external fan is protected by a guard from solid objects greater than 12 mm diameter and the remainder of the motor meets a higher IP rating then the higher IP rating may be claimed.

A smooth rotating shaft is not considered dangerous.

It is the responsibility of the customer or machine builder to ensure that any exposed shafts or couplings which are intended to allow the machine to be integrated into an assembly or finished product are appropriately protected.

Second (IP) Number

Protection of the machine from harmful ingress of water (limited ingress with no harmful effects is permitted)

IP	Requirements
0	No protection
1	Protected from vertically dripping water with machine mounted in normal position
2	Protected from dripping water from an angle up to 15 degrees from the vertical
3	Protected from spraying water falling from an angle up to 60 degrees from the vertical
4	Protected from splashing water from any direction
5	Protected from jets of water from any direction
6	Protected from powerful jets of water from any direction
7	Protected from powerful jets of water from any direction and from immersion under specified conditions of pressure and time
8	Protected from powerful jets of water from any direction and from continuous immersion under specified conditions of pressure

ERMEC, S.L. BARCELONA
C/ Francesc Teixidó, 22
E-08918 Badalona
(Spain)

Tel.: (+34) 902 450 160
Fax: (+34) 902 433 088
info@ermec.com
www.ermec.com

ERMEC, S.L. MADRID
C/ Sagasta, 8, 1ª planta
E-28004 Madrid
(Spain)

PORTUGAL
portugal@ermec.com
BILBAO
bilbao@ermec.com

:: Global Network ::

Australia
Eastland Electric Motors
T: +61 3 9879 1798 | www.au.parvalux.com

Austria & Czech Republic
Kwapil & Co GmbH
T: +43 1278 8585 | www.kwapil.com

Belgium
Mak Coeurderoi NVSA
T: +32 3740 0040 | www.makcoeurderoi.be

China
Euro-me
T: +86 755 83842750 | www.euro-me.com

Colombia
Inpraind SA
T: +57 4393 5238 | www.inpraindsa.com

Denmark
Parlock AS
T: +45 4390 6100 | www.parlock.dk

Finland
Finndrive OY
T: +35 82 0778 0890 | www.finndrive.fi

France
Parvalux
T: +33 1 3043 7273 | www.parvalux.fr

Germany & Netherlands
Parvalux
T: +49 64 3490 6624 | www.parvalux.de

Hungary
Q-Tech Engineering Ltd
T: +36 1405 3338 | www.q-tech.hu

USA & Canada
TC International
T: +1 845 2587482 | www.parvalux.com

India
Melkev Machinery
T: +91 22 2500 8154 | www.melkev.com

Italy
Log Italia srl
T: +39 3 3154 2800 | www.log-italia.it

Poland
Parvalux
T: +48 22 629 73 48 | www.parvalux.pl

South Africa
Parvalux
T: +27 1 1622 6826 | www.parvalux.co.za

Spain
Ermec sl
T: +34 9 3450 1600 | www.ermec.com

Sweden
SDT AB
T: +46 4238 0800 | www.sdt.se

Switzerland
Electro Müller AG
T: +41 3 2344 1010 | www.electro-mueller.ch

United Kingdom
Parvalux Midlands
T: +44 121 552 6581 | www.parvalux.co.uk

United Kingdom
Brammer Ltd
T: +44 1902 421336 | www.brammer.co.uk

United Kingdom
R.S. Components Ltd
T: +44 1536 201234 | www.rswww.com

ERMEC, S.L. BARCELONA
C/ Francesc Teixidó, 22
E-08918 Badalona
(Spain)

Tel.: (+34) 902 450 160
Fax: (+34) 902 433 088
info@ermec.com
www.ermec.com

ERMEC, S.L. MADRID
C/ Sagasta, 8, 1ª planta
E-28004 Madrid
(Spain)

PORTUGAL
portugal@ermec.com
BILBAO
bilbao@ermec.com

Parvalux Electric Motors Ltd.
490 Wallisdown Road, Bournemouth BH11 8PU, United Kingdom
Tel: +44 (0) 1202 512575 | Fax: +44 (0) 1202 530885
Email: sales@parvalux.co.uk