

RCI58S/T HS

Hollow Shaft - Incremental Optical Encoder



PRECILEC optical incremental encoders are designed for accurately measuring speed and position of rotating shafts in industrial environment: machine tools, motor drives ...
They use a differential optical measurement and a ratio-metric processing of the signal for minimizing the temperature and photodiode aging effects.
Their universal complementary push-pull output interface and their large supply voltage range make them very easy to connect to most of electronic control units with high noise immunity.



Main features

- Shaft type: Hollow shaft $\varnothing 14$ mm, and others diameters available (6, 8, 10, 12 mm) with reduction ring in aluminium
- Housing diameter: 58 mm
- Fixation: Spring plates with 2 or 3 fixation arms
- Body - Cover: Aluminium – Zamac
- Shaft: Stainless steel
- Pulses per turn: Up to 10.000 ppr
- Output signals: A & B with gated Z, and negatives
- Connections: Radial cable or M23
- Operating temperature range: $- 30^{\circ}\text{C} / + 100^{\circ}\text{C}$ (standard resolutions) / $- 20^{\circ}\text{C} / + 80^{\circ}\text{C}$ (specific resolutions)

Outline drawings

Spring plate with two fixation arms (2), with radial cable (CA02)

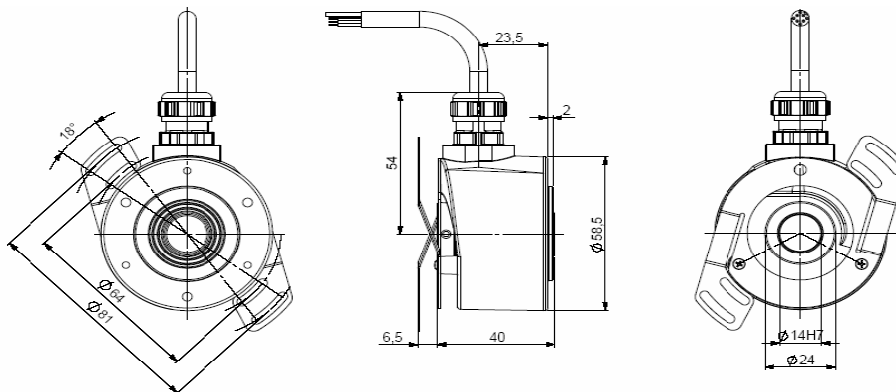

Spring plate with two fixations (2), with M23 connector (23C0)

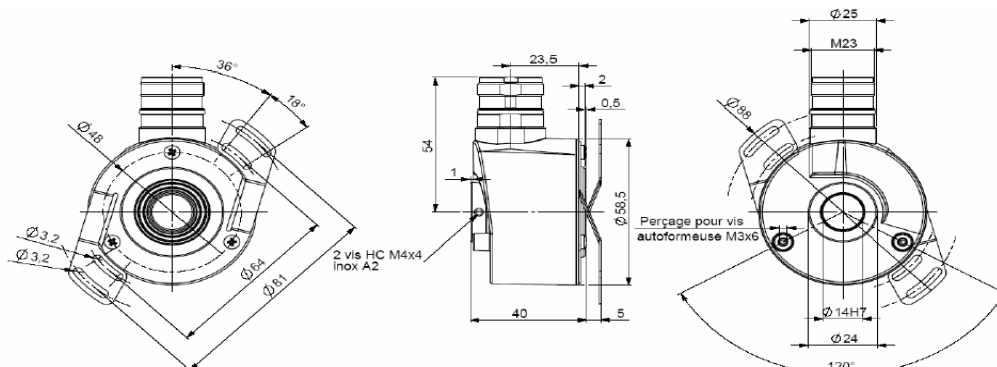

RCI58S/T HS

Hollow Shaft - Incremental Optical Encoder

Electrical characteristics

	Standard resolutions		Specific resolutions	
Supply voltage	5 to 30 Vdc	5 Vdc	11 to 30 Vdc	5 Vdc
Output signals	Push-pull (T)	RS422 (S)	Push-pull (T)	RS422 (S)
Max output frequency	300 kHz		100 kHz	
Max load current per channel	40 mA max			
EMC	According to EN 61000-6-2 and EN 50081-1			

Connections

	Cable - 8 wires	M23 - CW	M23 - CCW	Output waveforms
A	green	3	8	
A /	pink	6	1	
B	yellow	4	5	
B /	blue	7	6	
Z	grey	5	3	
Z /	red	8	4	
Vcc (+)	brown	2	2 + 12	
Gnd (-)	white	1	10 + 11	
Ground case	General shielding	Connector body	Connector body	

Mechanical characteristics

- Max continuous speed 6 000 rpm
- Max permissible speed 9 000 rpm
- Starting torque $\leq 6.10^{-3}$ N.m
- Shaft Inertia $\leq 2,2.10^{-6}$ kg.m²
- Weight 300 gr
- Protection IP 65 (EN 60529)
- Max shock ≤ 500 m.s⁻² (during 6 ms) (EN60068-2-27)
- Max vibrations ≤ 100 m.s⁻² (55 ... 2 000 Hz) (EN60068-2-6)

Ordering code

RCI58T-HS14-1-01024-CA02

Output signal Ø Spring plate Resolution Connection

- **Output signals** T (Push-Pull) S (RS422)
- **Diameters** 14 (14 mm)
- **Spring plates** 06 (6 mm), 08 (8 mm), 10 (10 mm) and 12 (12) mm with reduction ring in aluminium
- **Standard resolutions** 2 (2 fixation arms, standard) 3 (3 fixation arms)
- **Standard resolutions** 5 10 20 25 30 50 60 100 120 125 127 150 180 200 240 250 256 300 314 360 375 400 500 512 600 720 750 768 800 927 1000 1024 1200 1250 1280 1440 1500 1800 2000 2048 2400 2500 3000 3600 4000 4096 5000 6000 7200 8000 8192 10000
- **Specific resolutions** Any others resolutions available from 1 to 2499
- **Connections** CA02: Cable, two meters standard length. Other lengths from 1 to 10 meters on request
23C0: M23 connector, 12 pins clockwise
23A0: M23 connector, 12 pins counter-clockwise
Other connections on request