



BXUV.L564
Fire Resistance Ratings - ANSI/UL 263

[Page Bottom](#)

Design/System/Construction/Assembly Usage Disclaimer

- Authorities Having Jurisdiction should be consulted in all cases as to the particular requirements covering the installation and use of UL Listed or Classified products, equipment, system, devices, and materials.
- Authorities Having Jurisdiction should be consulted before construction.
- Fire resistance assemblies and products are developed by the design submitter and have been investigated by UL for compliance with applicable requirements. The published information cannot always address every construction nuance encountered in the field.
- When field issues arise, it is recommended the first contact for assistance be the technical service staff provided by the product manufacturer noted for the design. Users of fire resistance assemblies are advised to consult the general Guide Information for each product category and each group of assemblies. The Guide Information includes specifics concerning alternate materials and alternate methods of construction.
- Only products which bear UL's Mark are considered as Classified, Listed, or Recognized.

Fire Resistance Ratings - ANSI/UL 263

[See General Information for Fire Resistance Ratings - ANSI/UL 263](#)

Design No. L564

February 06, 2009

Unrestrained Assembly Rating - 1 Hr

Load Restricted for Canadian Applications — See Guide [BXUV7](#)

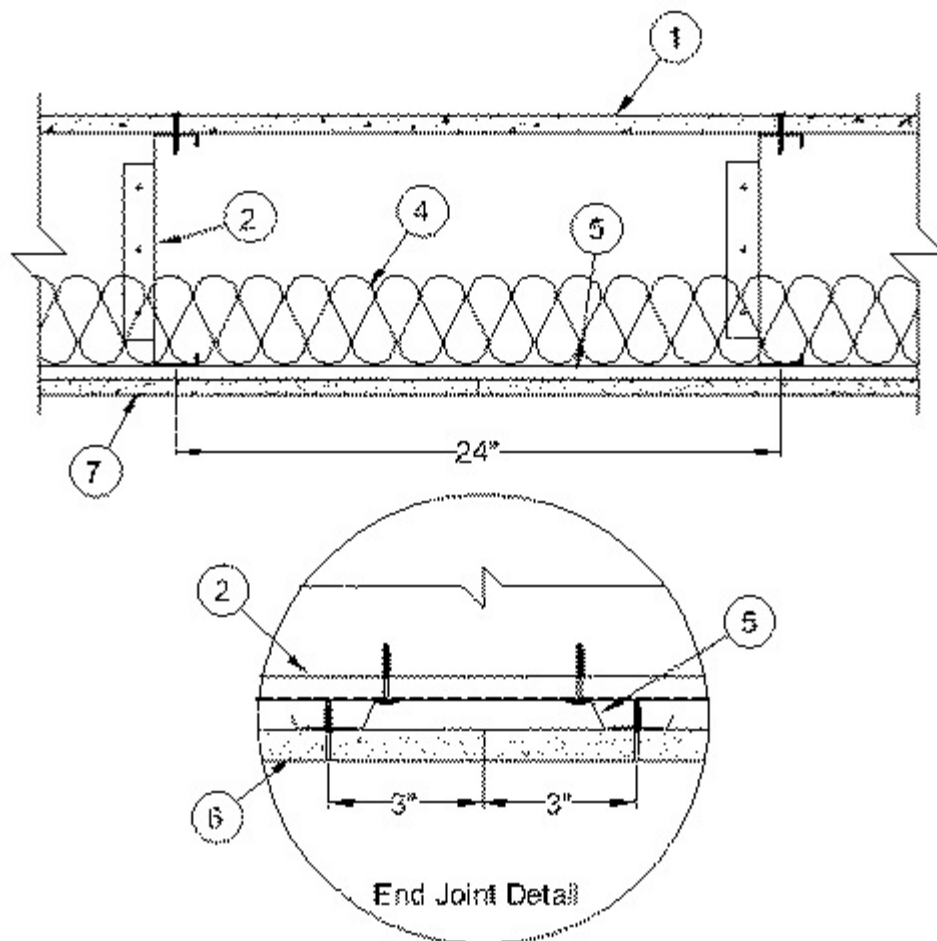

1. **Flooring System - Structural Cement-Fiber Units*** — Minimum Nom 3/4 in. (19 mm) thick, with long edges tongue and grooved. Long dimension of panels to be perpendicular to joists with end joints staggered. Panels secured to steel joists with 1-5/16 in. (33 mm) long No. 8 self-drilling, self-countersinking steel screws spaced 12 in. (305 mm) OC in both the field and perimeter and located 1 in. (25 mm) from the side edges of the board. "Enerbond" 45 spray foam adhesive applied to butt joints and to tongue and grooved edges of flooring during installation. When panels thicker than 3/4 in. are used the minimum fastener length shall be the thickness of the panel plus 9/16 in.

VIROC/PORTUGAL INDUSTRIAS DE MADEIRA

E CIMENTO S A

1A. **Flooring Topping Systems (Not Shown)** — As an option, one of the following floor topping systems may be provided.

System No. 1

Vapor Barrier - (Optional) — Nom 0.030 in. thick commercial asphalt saturated felt.

Floor Mat Material* — Nom 1/4 in. thick floor mat material loose laid over the flooring system. Maxxon Floor Primer to be applied to the surface of the mat prior to the floor-topping placement. When floor mat material is used, min thickness of floor-topping mixture is 1 in.

MAXXON CORP — Type Acousti-Mat II

Alternate Floor Mat Material* — Nom 0.8 in. thick floor mat material loose laid over the flooring system with Crack Suppression Mat (CSM) loose laid over the floor mat material. Floor-topping thickness shall be min 1-1/2 in.

MAXXON CORP — Type Acousti-Mat 3, Crack Suppression Mat (CSM)

Metal Lath — (Alternate to Crack Suppression Mat (CSM)) — 3/8 in. expanded galvanized steel diamond mesh, 3.4 lbs/sq yd loose laid over the floor mat material. Floor-topping thickness shall be min 1-1/2 in.

Alternate Floor Mat Material* — Nom 0.4 in. thick floor mat material loose laid over the flooring system. Maxxon Floor Primer to be applied to the surface of the mat prior to the floor-topping placement. Floor-topping thickness shall be min 1-1/2 in.

MAXXON CORP — Type Enkasonic 9110

Alternate Floor Mat Materials* - (Optional) — Nom 0.2 in. thick floor mat material loose laid over the subfloor. Maxxon Floor Primer may be applied to the surface of the mat prior to the floor topping placement. Floor topping thickness shall be as specified under **Floor Topping Mixture**.

MAXXON CORP — Type Acousti-Mat LP-R

Metal Lath — (Optional) — For use with floor mat materials, 3/8 in. expanded galvanized steel diamond mesh, 3.4 lbs/sq yd or Maxxon Corp. UL Classified Crack Suppression Mat (CSM) loose laid over the floor mat material. Floor-topping thickness shall be min 1 in.

MAXXON CORP — Type Crack Suppression Mat (CSM)

Floor Topping Mixture* — Min 3/4 in. thickness of floor-topping mixture depending upon floor mat system as specified above, having a min compressive strength of 1000 psi. Mixture shall consist of 3 to 7 gal of water to 80 lbs of floor-topping mixture to 1.0 to 2.1 cu ft of sand.

MAXXON CORP — Type D-C, GC, GC2000, L-R, T-F, CT

System No. 2

Vapor Barrier - (Optional) — Nom 0.030 in. thick commercial asphalt saturated felt.

Floor Mat Material* — Nom 1/4 in. thick floor mat material loose laid over the flooring system. Maxxon Floor Primer to be applied to the surface of the mat prior to the floor-topping placement. When floor mat material is used, min thickness of floor-topping mixture is 1 in.

MAXXON CORP — Type Acousti-Mat II

Alternate Floor Mat Material* — Nom 0.8 in. thick floor mat material loose laid over the flooring system with Crack Suppression Mat (CSM) loose laid over the floor mat material. Floor-topping thickness shall be min 1-1/2 in.

MAXXON CORP — Type Acousti-Mat 3, Crack Suppression Mat (CSM)

Metal Lath — (Alternate to Crack Suppression Mat (CSM)) — 3/8 in. expanded galvanized steel diamond mesh, 3.4 lbs/sq yd loose laid over the floor mat material. Floor-topping thickness shall be min 1-1/2 in.

Alternate Floor Mat Material* — Nom 0.4 in. thick floor mat material loose laid over the flooring system. Maxxon Floor Primer to be applied to the surface of the mat prior to the floor-topping placement. Floor-topping thickness shall be min 1-1/2 in.

MAXXON CORP — Type Enkasonic 9110

Alternate Floor Mat Materials* - (Optional) — Nom 0.2 in. thick floor mat material loose laid over the subfloor. Maxxon Floor Primer may be applied to the surface of the mat prior to the floor topping placement. Floor topping thickness shall be as specified under **Floor Topping Mixture**.

MAXXON CORP — Type Acousti-Mat LP-R

Metal Lath (Optional) — For use with floor mat materials, 3/8 in. expanded galvanized steel diamond mesh, 3.4 lbs/sq yd or Maxxon Corp. UL Classified Crack Suppression Mat (CSM) loose laid over the floor mat material. Floor-topping thickness shall be min 1 in.

MAXXON CORP — Type Crack Suppression Mat (CSM)

Floor Topping Mixture* — Min 3/4 in. thickness of floor-topping mixture depending upon floor mat system as specified above, having a min compressive strength of 1200 psi. Mixture shall consist of 4 to 7 gal of water to 80 lbs of floor-topping mixture to 1.4 to 1.9 cu ft of sand.

RAPID FLOOR SYSTEMS — Type RF, RFP, RFU, RFR, Orcrete

System No. 3

Subflooring — Min 3/4 in. thick wood structural panels, min grade "Underlayment" or "Single-Floor". Face grain of plywood or strength axis of panel to be perpendicular to joists with joints staggered. Long edges may be T & G or square.

Finish Flooring — Floor Topping Mixture* — Compressive strength to be 2500 psi min. Thickness to be 3/4 in. min. Refer to manufacturer's instructions accompanying the material for specific mix design.

ALPHA 7 GYPSUM L L C — EarthSmart Gypsum Cement Commercial Floor Topping

Floor Mat Materials* — (Optional)— Floor mat material nom 1/4 in. thick adhered to subfloor with Alpha 7 Gypsum Floor Primer. Primer to be applied to the surface of the mat prior to the placement of a min 1 in. of floor-topping mixture.

ALPHA 7 GYPSUM L L C — Type EarthSmart SCM WL.

Floor Mat Materials* — (Optional)— Floor mat material nom 6 mm thick adhered to subfloor with Alpha 7 Gypsum Floor Primer. Primer to be applied to the surface of the mat prior to the placement of a min 1 in. of floor-topping mixture.

ALPHA 7 GYPSUM L L C — Type EarthSmart SCM RT.

2. **Structural Steel Members*** — The proprietary joists are channel-shaped, min 9-1/4 in. (235 mm) deep. Joists are fabricated from min No. 16 MSG galv steel. Joists spaced max 24 in. (610 mm) OC. Joists attached to joist rim with three 3/4 in. (19 mm) long No. 10 x 16 self-drilling steel TEK screws through tab to the outside of the web. At joist rim splices bearing on supports, joists rims are connected using an overlapping section of a 12 in. (305 mm) long splice plate (a joist piece), with four 3/4 in. (19 mm) long No. 10 x 16 self-drilling steel TEK screws to each rim piece.

DIETRICH INDUSTRIES INC — Type TDJ or TDW Floor Joists, TD24 Rim Joist

3. **Joist Bridging - (Not Shown)** — Installed at the center of the joist span immediately after joists are erected and before construction loads are applied. The bridging (2-1/2 TDSB18) consists of No. 18 MSG galv steel channels, 2-1/2 in. (64 mm) wide by 1-1/4 in. (32 mm) deep by 21-3/4 in. (552 mm) long with 2-1/8 in. (54 mm) long web extensions at each end for screw-attachment to the bottom flange of the steel joists with a 3/4 in. (19 mm) long No. 10 x 16 self-drilling steel TEK screw. Solid bridging consisting of cut - to-length joist sections placed between the outermost joists and between the centermost joists with a max spacing of 8 ft (2.4 m) OC. Solid bridging are screw-attached at joist web using a 1-1/2 by 1-1/2 by 7 in. (38 by 38 by 178 mm) long, No. 16 MSG, min 50 ksi steel support clip (EasyClip S-Series S547) with two 3/4 in. (19 mm) long No. 10 x 16 self-drilling steel TEK screws per leg on one side and on the other side with a 4 by 1-1/2 by 7 in. (102 by 38 by 178 mm) long No. 16 MSG, min 50 ksi steel support clip (EasyClip E-Series E547) with two 3/4 in. (19 mm) long No. 10 x 16 self-drilling steel TEK screws per leg.

4. **Batts and Blankets*** — Min 3-5/8 in. (92 mm) thickness of mineral wool or glass fiber insulation friction-fit between structural steel members, and supported by the resilient channels (Item 5). Any mineral wool or glass fiber insulation bearing the UL Classification Marking for Surface Burning Characteristics having a flame spread index of 25 or less and a smoke developed index of 50 or less may be used.

See **Batts and Blankets** (BKNV) category in the Building Materials Directory for names of manufacturers.

5. **Resilient Channels** — Resilient channels, formed of No. 25 MSG galv steel, 1/2 in. (13 mm) deep, spaced max 12 in. (305 mm) OC perpendicular to joists. Channel splices located beneath trusses and overlapped 4 in. (102 mm). Channels secured to each joist with one 1/2 in. (13 mm) long Type S-12 low profile steel screw. Two channels, spaced 6 in. (152 mm) OC, oriented opposite each gypsum board end joint as shown in end joint detail. Additional channels shall extend min 6 in. beyond each side edge of board.

5A. **Steel Framing Members* - (Optional, Not Shown)** — When it is desired to drop the ceiling below the bottom plane of the structural steel members, steel framing members may be used in addition to the resilient channels (Item 5) which must be retained to support the mineral wool or glass fiber insulation. Nom 12 ft (3.66 m) long main runners installed perpendicular to structural steel members and spaced 48 in. (1.22 m)

OC. Main runners suspended from structural steel members with No. 12 SWG galv steel hanger wires reliably secured to the bottom flange of the structural steel members with screw-attached steel clips and spaced max 48 in. (1.22 m) OC. Nom 4 ft (1.22 m) long cross tees with 1-1/2 in. (38 mm) wide face installed perpendicular to main runners and spaced max 16 in. (406 mm) OC. Cross tees located 4 in. (102 mm) from each side of butted gypsum board end joints. Ends of steel framing members at walls to be supported by galv or painted steel angles or channels with min 1 in. (25 mm) horizontal leg.

ARMSTRONG WORLD INDUSTRIES INC — Type DFR-8000

5B. Alternate Steel Framing Members* — (Optional, Not Shown) — As an alternate to Item 5A. When it is desired to drop the ceiling below the bottom plane of the structural steel members, alternate steel framing members may be used in addition to the resilient channels (Item 5) which must be retained to support the mineral wool or glass fiber insulation. For use in corridors or rooms having a maximum width dimension of 14 ft (4.25 m). Steel framing members consist of grid runners, locking angle wall molding and hanger bars. Locking angle wall molding secured to walls with steel nails or screws spaced max 16 in. (610 mm) OC. Slots of locking angle wall molding parallel with hanger bars to be aligned with tabbed cutouts in bottom edge of hanger bars. Hanger bars spaced max 50 in. (1.22 m) OC and suspended with No. 12 AWG steel hanger wires spaced max 48 in. (1.22 m) OC. Adjoining lengths of hanger bar to overlap 12 in. (305 mm) and to be secured together and suspended by a shared hanger wire. A min clearance of 1/4 in. (6 mm) shall be maintained between the ends of the hanger bars and the walls. Grid runners cut-to-length and installed perpendicular to hanger bars and spaced max 16 in. (406 mm) OC with additional grid runners installed 8 in. (203 mm) OC at gypsum board end joints. Grid runners parallel with walls to be spaced max 16 in. (406 mm) from wall. Ends of grid runners to rest on and engage slots of locking angle wall molding with a clearance of 3/8 in. (10 mm) to 1/2 in. (13 mm) maintained between each end of the grid runner and the wall. Bulb of grid runner to be captured by tabbed cutouts in bottom edge of hanger bars.

ARMSTRONG WORLD INDUSTRIES INC — Type DFR-8000-SS

5C. Alternate Steel Framing Members* — (Not Shown) — As an alternate to Items 5, 5A and 5B. Main runners nom 12 ft (3.66 m) long, spaced 72 in. (1.83 m) OC. Cross tees, nom 6 ft (1.83 m) long, installed perpendicular to main runners and spaced 16 in. (406 mm) OC. Additional 6 ft long cross tees required at each gypsum board end joint with butted gypsum board end joints centered between cross tees spaced 8 in. (203 mm) OC. The main runners and cross tees may be riveted or screw-attached to the wall angle or channel to facilitate the ceiling installation.

ARMSTRONG WORLD INDUSTRIES INC — Type DFR-8000

5D. Steel Framing Members* — (Optional, Not Shown) - Used as an alternate method to attach min 1/2 in. deep resilient channels (Item 5) to structural steel members (Item 2). Resilient channels are friction fitted into clips, and then clips are secured to the bottom flange of each structural steel member with a min. 1 in. long Type S-12 low profile steel screw through the center hole of the clip and the resilient channel flange. Adjoining resilient channels are overlapped 4 in. under structural steel members. The clip flange is opened slightly to accommodate the two overlapped channels. Additional clips required to hold resilient channel that supports the gypsum board butt joints, as described in Item 6.

KEENE BUILDING PRODUCTS CO INC — Type RC Assurance.

6. Gypsum Board* — One layer of 5/8 in. (16 mm) thick by 48 in. (1.22 m) wide gypsum board installed with long dimension perpendicular to resilient channels and with side joints located midway between the structural steel members. Gypsum board secured to resilient channels or to the steel framing member cross tees with 1 in. (25 mm) long Type S bugle head screws spaced 8 in. (203 mm) OC in the field and along butt joints of the board. Screws located 1-1/2 in. (38 mm) and 3 in. (76 mm) from the side edges and butted end joints of the board, respectively. End joints secured to both resilient channels as shown in end joint detail.

When alternate **Steel Framing Members*** (Item 5B) are used, gypsum board sheets installed with long dimension (side joints) perpendicular to the grid runners with the end joints staggered min 4 ft (1.22 m) and centered between grid runners which are spaced 8 in. (203 mm) OC. Prior to installation of the gypsum board sheets, backer strips consisting of nom 7-3/4 in. (197 mm) wide by 48 in. (1.22 m) long pieces of gypsum board are to be laid atop the grid runner flanges and centered over each butted end joint location. The backer strips are to be secured to the flanges of the grid runners at opposite corners of the backer strip to prevent the backer strips from being uplifted during screw-attachment of the gypsum board sheets. Gypsum board fastened to grid runners with drywall screws spaced 1 in. (25 mm) and 4 in. (102 mm) from the side joints and max 8 in. (203 mm) OC in the field of the board. The butted end joints are to be secured to the backer strip with No. 10 by 1-1/2 in. (38 mm) long Type G laminating screws located 1 in. (25 mm) from each side of the butted end joint and spaced 1 in. (25 mm) and 4 in. (102 mm) from the side joints and max 8 in. (203 mm) OC in the field of the board. Joints to be covered with paper tape and joint compound.

When alternate **Steel Framing Members*** (Item 5C) are used, gypsum board sheets installed with long dimension (side joints) perpendicular to the 6 ft long cross tees with the end joints staggered min 4 ft (1.22

m) and centered between cross tees which are spaced 8 in. (203 mm) OC. Gypsum board side joints may occur beneath or between main runners. Prior to installation of the gypsum board sheets, backer strips consisting of nom 7-3/4 in. (197 mm) wide pieces of gypsum board are to be laid atop the cross tee flanges and centered over each butted end joint location. The backer strips are to be secured to the flanges of the cross tees at opposite corners of the backer strip to prevent the backer strips from being uplifted during screw-attachment of the gypsum board sheets. Gypsum board fastened to cross tees with drywall screws spaced 1 in. (25 mm) and 4 in. (102 mm) from the side joints and max 8 in. (203 mm) OC in the field of the board. The butted end joints are to be secured to the backer strip with No. 10 by 1-1/2 in. (38 mm) long Type G laminating screws located 1 in. (25 mm) from each side of the butted end joint and spaced 1 in. (25 mm) and 4 in. (102 mm) from the side joints and max 8 in. (203 mm) OC in the field of the board. Joints to be covered with paper tape and joint compound.

CANADIAN GYPSUM COMPANY — Type C

UNITED STATES GYPSUM CO — Type C

USG MEXICO S A DE C V — Type C

7. Finishing System - (Not Shown) — Vinyl, dry or premixed joint compound, applied in two coats to joints and screw-heads. Nom 2 in. (51 mm) wide paper tape embedded in first layer of compound over all joints. As an alternate, nom 3/32 in. (2 mm) thick veneer plaster may be applied to the entire surface of gypsum board.

*Bearing the UL Classification Mark

[Last Updated](#) on 2009-02-06

[Questions?](#)

[Notice of Disclaimer](#)

[Page Top](#)

[Copyright © 2010 Underwriters Laboratories Inc.®](#)

The appearance of a company's name or product in this database does not in itself assure that products so identified have been manufactured under UL's Follow-Up Service. Only those products bearing the UL Mark should be considered to be Listed and covered under UL's Follow-Up Service. Always look for the Mark on the product.

UL permits the reproduction of the material contained in the Online Certification Directory subject to the following conditions: 1. The Guide Information, Designs and/or Listings (files) must be presented in their entirety and in a non-misleading manner, without any manipulation of the data (or drawings). 2. The statement "Reprinted from the Online Certifications Directory with permission from Underwriters Laboratories Inc." must appear adjacent to the extracted material. In addition, the reprinted material must include a copyright notice in the following format: "Copyright © 2010 Underwriters Laboratories Inc.®"